

**REAR BUMPER GUARD
05-11 NISSAN XTERRA**

PARTS LIST:

1	Double Tube Rear Bumper Guard	12	12mm x 32mm OD x 3mm Flat Washers
2	Frame Mounting Brackets	2	12mm Lock Washers
2	12-1.25mm x 40mm Fine Thread Hex Bolts	6	12-1.75mm Nylon Lock Nuts
6	12-1.75mm x 35mm Hex Bolts		

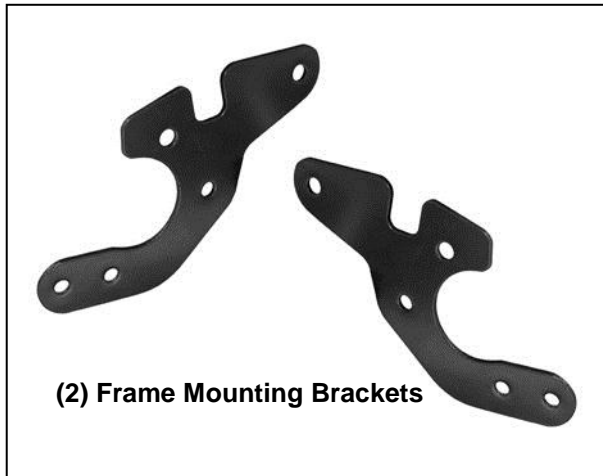

PROCEDURE:

REMOVE CONTENTS FROM BOX. VERIFY ALL PARTS ARE PRESENT. READ INSTRUCTIONS CAREFULLY BEFORE STARTING INSTALLATION. ASSISTANCE IS RECOMMENDED.

IMPORTANT! The mounting locations for the Frame Brackets are very close to the exhaust system. Allow exhaust system to cool completely before starting the installation.

1. Start on the passenger side, rear of the vehicle. Determine if the vehicle is equipped with tie down loops attached to the bottom of the frame channel.
 - a. **Vehicles with tie down loops:** Remove the (2) factory hex bolts in the side of the frame channel on the passenger side. Select (1) Frame Mounting Bracket. Bolt the Bracket to the side of the frame with the (2) factory hex bolts. Line up the hole in the center of the Bracket with the opening in the tie down loop. Bolt the Bracket to the loop with (1) 12mm x 35mm Coarse Thread Hex Bolt, (2) 12mm Large Flat Washers and (1) 12mm Nylon Lock Nut, **(Figure 1)**. Do not tighten hardware at this time. Repeat this Step for driver side Frame Bracket installation.
 - b. **Vehicles without tie down loops:** Remove the factory bumper bolt, **(Figure 2)**. Locate the threaded hole in the side of the frame channel, **(Figure 3B)**. **VERY IMPORTANT:** The threaded hole in the frame is 12-1.25mm Special Fine Thread. Insert the included (1) 12-1.25mm x 40mm Fine Thread Hex Bolt, (1) 12mm Lock Washer with (1) 12mm Flat Washer through the Bracket. Slide (1) 12mm Flat Washer over the Fine Thread Hex Bolt to act as a spacer between the Bracket and the frame channel, **(Figure 3A)**. Hold the Bracket in position and bolt it to the threaded hole, **(Figure 3B)**. Leave loose at this time. Rotate the Mounting Bracket up to the factory threaded hole in the bumper bracket. Bolt the Mounting Bracket to the bumper bracket with the previously removed factory hex bolt. Do not tighten hardware at this time. Repeat this Step for driver side Frame Bracket installation.

**REAR BUMPER GUARD
05-11 NISSAN XTERRA**

- Carefully position the Rear Bumper Guard up to the inside of the Frame Mounting Brackets. Attach the Rear Bumper Guard to the Mounting Brackets using the included (4) 12-1.75mm x 35mm Coarse Thread Hex Bolts, (8) 12mm Flat Washers and (4) 12mm Nylon Lock Nuts, **(Figure 4)**.
- Align and adjust the Rear Bumper Guard properly and tighten all mounting hardware.
- Do periodic inspections to the installation to make sure that all hardware is secure and tight.

To protect your investment, wax this product after installing. Regular waxing is recommended to add a protective layer over the finish. Do not use any type of polish or wax that may contain abrasives that could damage the finish.

For stainless steel: Aluminum polish may be used to polish small scratches and scuffs on the finish. Mild soap may be used also to clean the Rear Bumper Guard.

For gloss black finishes: Mild soap may be used to clean the Rear Bumper Guard.

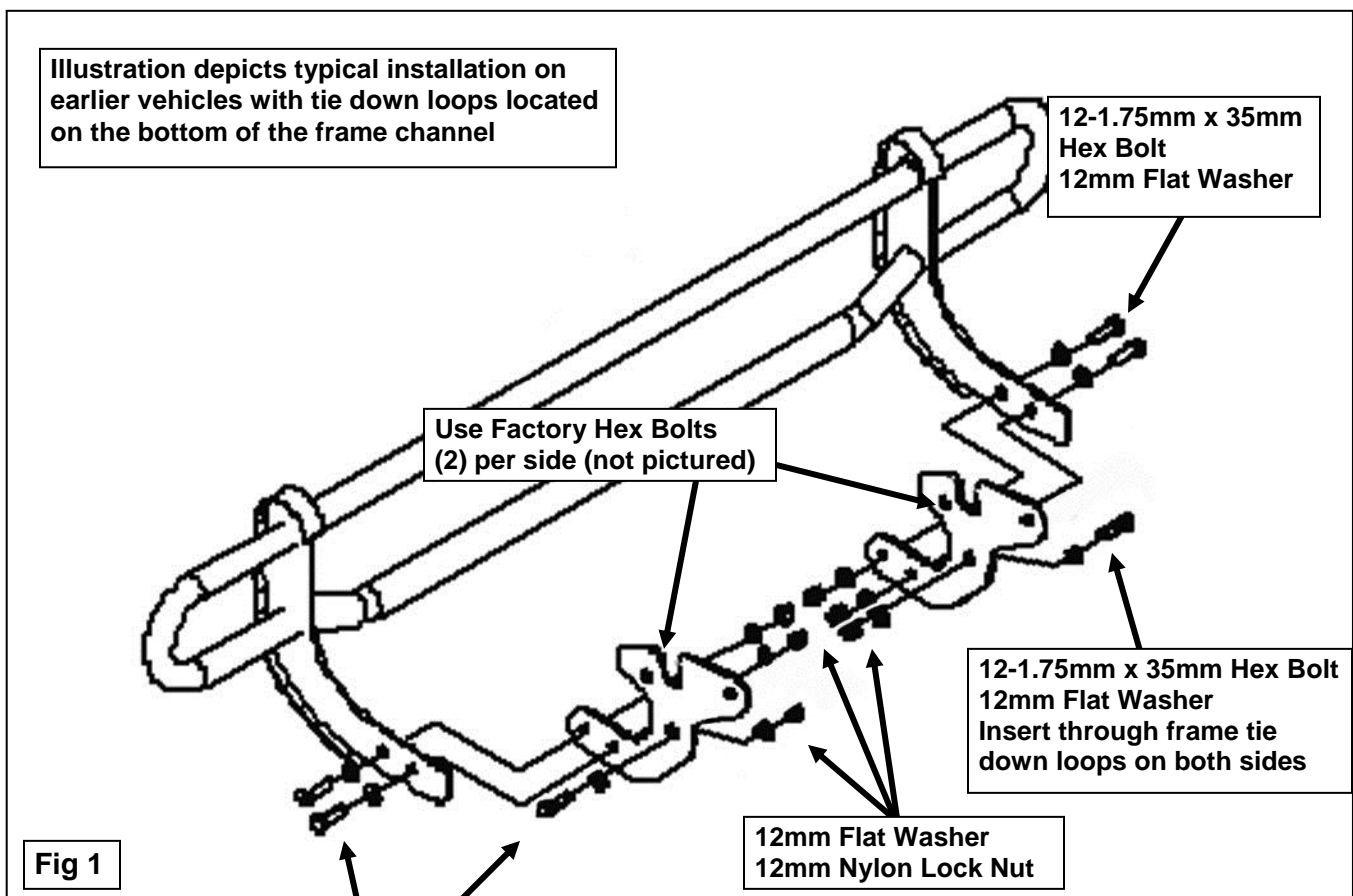

Muffler/Exhaust Pipe Warning:
IMPORTANT! Due to close proximity of the Frame Mounting Bracket to the exhaust pipe, allow exhaust pipe to cool before starting the installation.

Passenger Side Installation Pictured

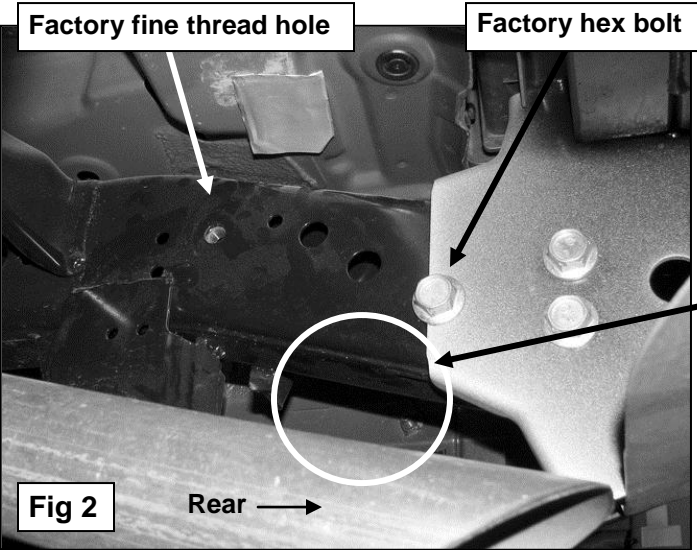

Installation pictured on later model vehicle without tie down loops and with large bumper bracket reinforcement

Installation on vehicles without tie down loops located on the bottom of the frame channel

12-1.25mm x 40mm Special Fine Thread Hex Bolt
12mm Lock Washer
(2) 12mm Flat Washers
(1 Flat Washer installed between Bracket and frame channel-Fig 3B)

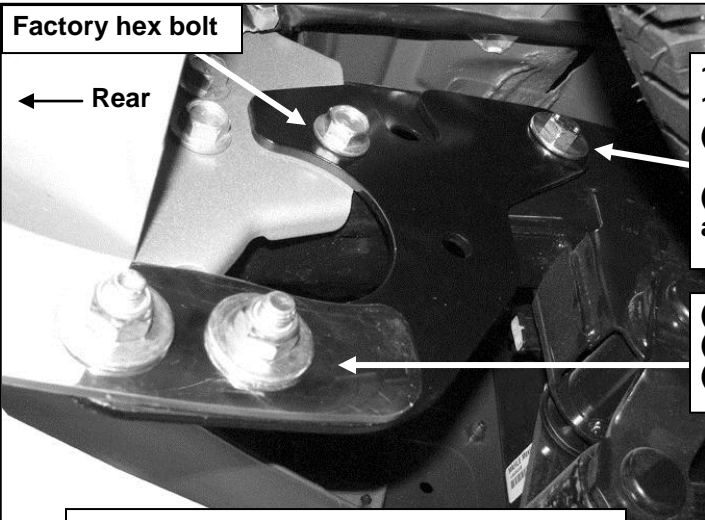
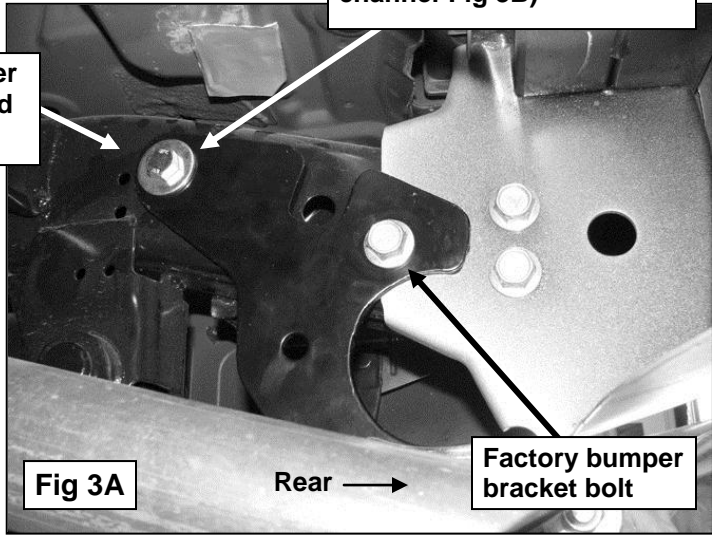
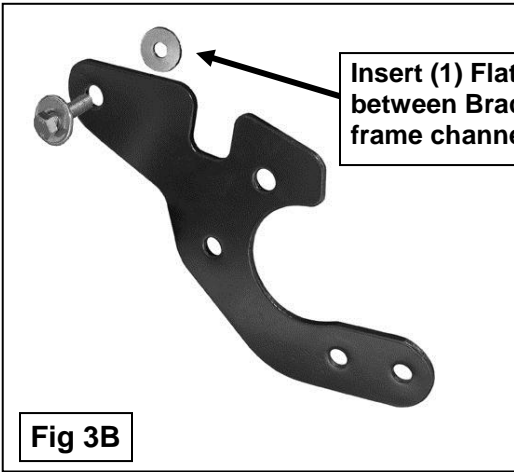

12-1.25mm x 40mm Fine Thread Hex Bolt
12mm Lock Washer
(2) 12mm Flat Washers
(1 Flat Washer installed between Bracket and frame channel-Fig 3B)

(2) 12-1.75mm x 35mm Hex Bolts
(4) 12mm Flat Washers
(2) 12mm Nylon Lock Nuts

Installation pictured on later model vehicle without tie down loops and with large bumper bracket reinforcement