



TEL: 1-866-XANATOS

INSTALLATION INSTRUCTIONS

PART # 8D080618SS/8D080618A

REAR BUMPER GUARD

JEEP GRAND CHEROKEE 2011 (DOUBLE TUBE)

PARTS LIST:

1	Rear Bumper Guard
2	Frame Mounting Brackets
4	12-1.75mm x 35mm Hex Bolts
8	12mm x 24mm OD x 2.5mm Flat Washers
4	12mm Lock Washers
4	12mm Hex Nuts

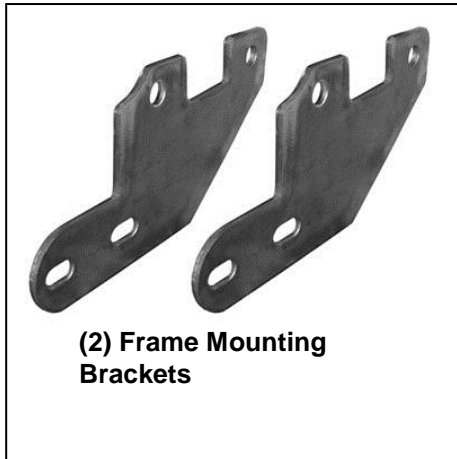

PROCEDURE:

REMOVE CONTENTS FROM BOX. VERIFY ALL PARTS ARE PRESENT. READ INSTRUCTIONS CAREFULLY BEFORE STARTING INSTALLATION. ASSISTANCE IS RECOMMENDED. MAY INTERFERE WITH BACKUP SENSOR OPERATION.

WARNING: ALLOW TIME FOR THE MUFFLER TO COOL COMPLETELY BEFORE INSTALLING REAR BUMPER GUARD BRACKETS.

1. Starting on the driver side of the vehicle, locate the (2) threaded holes in the left side upper frame rail, **(Figure 1)**. **NOTE:** These holes will be filled with hex bolts from the factory-remove hex bolts. Select (1) Frame Mounting Bracket. Bolt the Mounting Bracket to the frame rail with the factory 14mm hex bolts, **(Figure 2)**. Do not tighten hardware at this time. Repeat this step to install the Mounting Bracket on the passenger side. **NOTE:** It may be necessary to remove excess sealant from the body seam to provide additional clearance for the Mounting Bracket, **(Figure 1)**.
2. Carefully position the Rear Bumper Guard up to the inside of the Mounting Brackets. Bolt the Rear Bumper Guard to the Brackets using the included (4) 12mm x 35mm Hex Bolts, (8) 12mm Flat Washers, (4) 12mm Lock Washers and (4) 12mm Hex Nuts, **(Figure 3)**. Do not tighten hardware at this time.
3. Align Rear Bumper Guard and tighten all hardware.
4. Do periodic inspections of the installation to make sure that all hardware is secure and tight.

To protect your investment, wax this product after installing. Regular waxing is recommended to add a protective layer over the finish. Do not use any type of polish or wax that may contain abrasives that could damage the finish.

For stainless steel: Aluminum polish may be used to polish small scratches and scuffs on the finish. Mild soap may be used also to clean the Bumper Guard.

For gloss black finishes: Mild soap may be used to clean Bumper Guard.

Driver Side Installation Pictured

Remove factory hex bolts

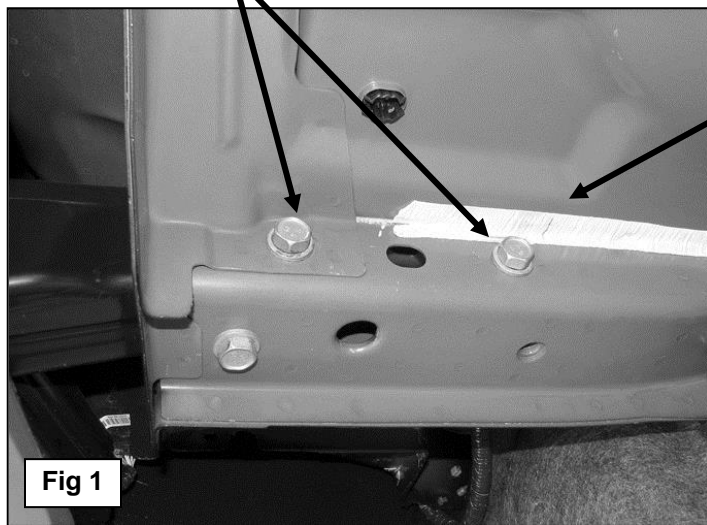

Trim or remove excess sealant as necessary to clear bracket for proper fitment

Bolt Mounting Bracket to side of frame channel with factory hex bolts

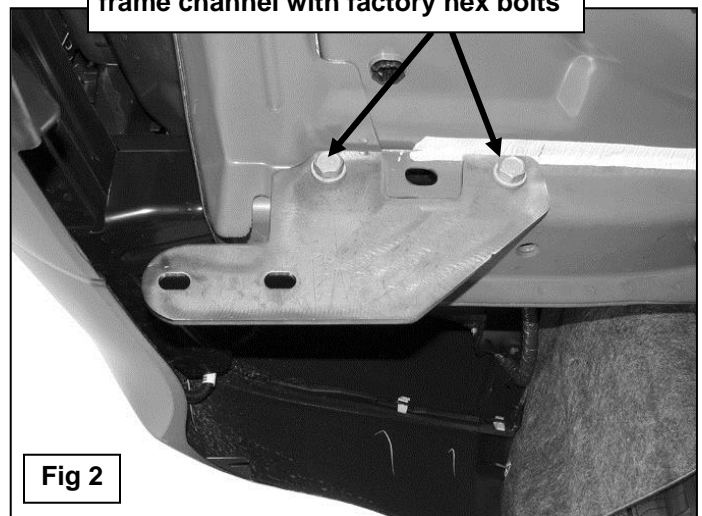

(2) 12mm x 35mm Hex Bolts
(4) 12mm Flat Washers
(2) 12mm Lock Washers
(2) 12mm Hex Nuts

