

Parts List:

Qty	Description	Qty	Description
1	Driver/Left Running Board	2	10mm Lock Washers
1	Passenger/Right Running Board	2	10mm x 27mm OD x 3mm Flat Washers
2	Driver/Left Front/Center Brackets	2	10-1.50mm Hex Nuts
2	Passenger/Right Front/Center Brackets	4	8-1.25mm x 30mm Hex Bolt
4	Front/Center Support Brackets	10	8-1.25mm x 20mm Hex Bolt
1	Driver/Left Rear Bracket	24	8mm x 22mm OD x 2mm Flat Washers
1	Passenger/Right Rear Bracket	4	8mm Lock Washer
1	Driver/Left Rear Support Bracket	10	8-1.25mm Nylon Lock Nut
1	Passenger/Right Rear Support Bracket	12	6-1.0mm x 20mm T-Bolts
2	8-1.25mm Threaded Insert	10	6-1.00mm x 25mm Hex Bolt
1	8mm Insert Installation Tool	12	6mm x 22mm OD x 2mm STD Flat Washers
2	12mm-10mm Double Bolt Plates	20	6mm x 12mm OD x 1.6mm Small Flat Washers
2	12mm x 44mm OD x 4mm Fender Washers	12	6mm Lock Washers
2	12mm Lock Washer	10	6mm Nylon Lock Nut
2	12-1.75mm Hex Nut	12	6mm Hex Nuts

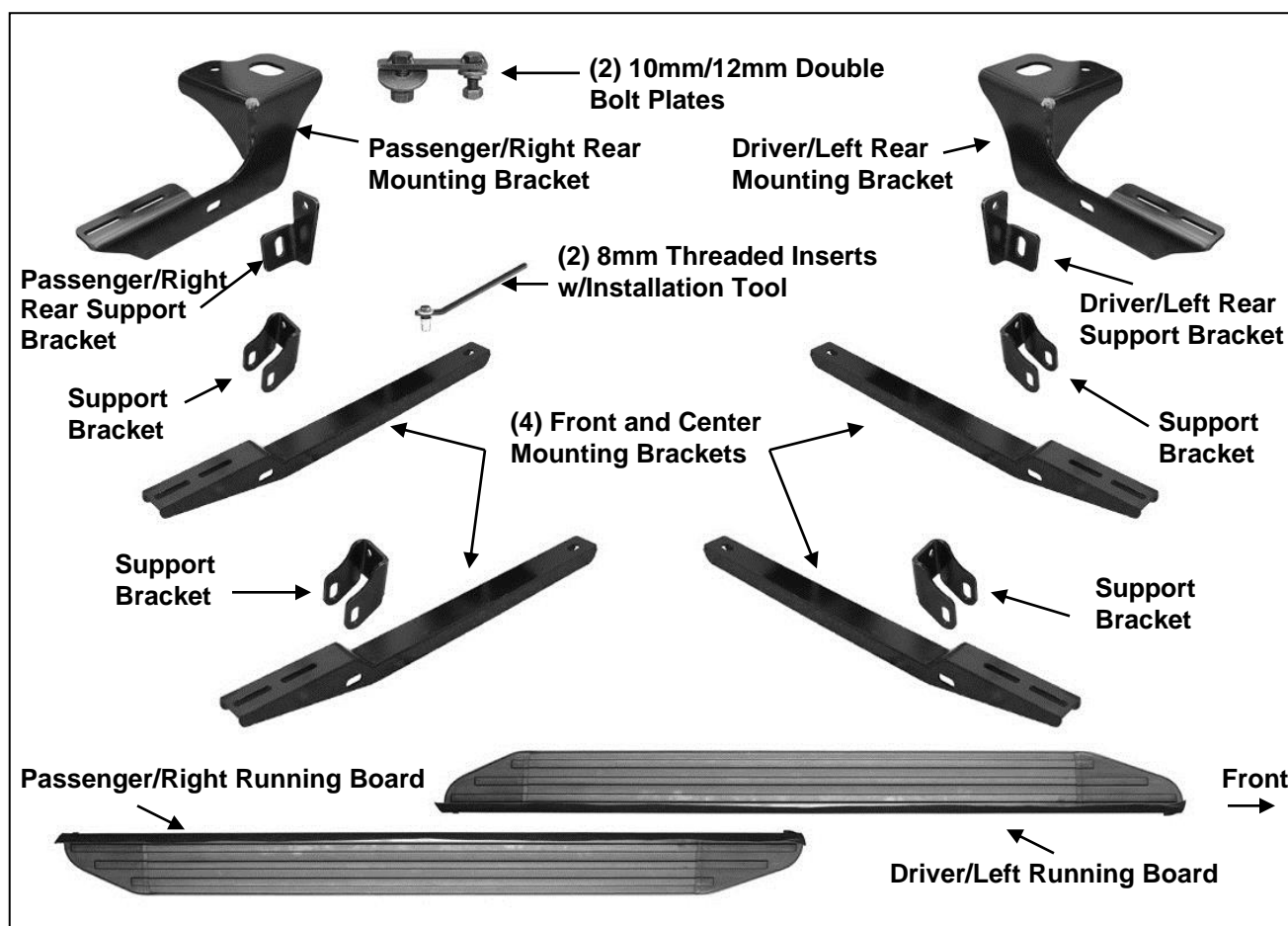

PROCEDURE:

- 1. REMOVE CONTENTS FROM BOX. VERIFY ALL PARTS ARE PRESENT. READ INSTRUCTIONS CAREFULLY. ASSISTANCE IS RECOMMENDED. CUTTING AND DRILLING IS REQUIRED.**
- Start installation under the driver side of the vehicle. Locate and remove the plastic cover from the floor panel if equipped. Pay close attention to the location of all fasteners for the plastic cover.
- Locate the (2) factory hex bolts connecting the bottom of the frame channel, (**Figure 1**). Remove the rear hex bolt only, (**Figure 2**).

4. Select (1) Front/Center Mounting Bracket and (1) Front/Center Support Bracket, **(Figure 3)**. Bolt the Support Bracket to the top of the Mounting Bracket with (2) 8mm x 20mm Hex Bolts, (4) 8mm Flat Washers and (2) 8mm Nylon Lock Nuts, **(Figures 3 & 4)**. Leave hardware loose at this time.
5. Attach the front Bracket Assembly, (with the Support Bracket on the outside of the pinch weld), to the bottom of the frame channel with (1) 8mm x 30mm Hex Bolt, (1) 8mm Lock Washer and (1) 8mm Flat Washer, **(Figure 4)**. Do not fully tighten hardware at this time.
6. Move along the driver side of the vehicle and locate the (2) factory holes, (one small, one slightly larger), mid way along the bottom of the frame channel between the front and rear tires, **(Figures 5 & 7A)**. Hold the plastic cover, (if equipped), up in position and locate the small center mounting hole in the bottom of the frame channel for the cover, **(Figure 18A)**. Locate the larger 7/16" unused factory hole 2-1/4" directly in front of the hole for the cover.
7. Select (1) 8mm Threaded Insert, (1) Insert Tool, (1) 8mm x 30mm Hex Bolt and (1) 8mm Flat Washer. Assemble the Insert Tool as per **Figure 6**. Push the Insert into the 7/16" unused factory hole. If the Insert is too tight to install, (push into hole), by hand, lightly tap into position with small hammer. Be careful to avoid damaging the Insert. **NOTE:** Insert will only fit into the 7/16" "unused factory hole" and will not fit into the smaller hole used for the factory fastener for the cover, **(Figure 7A)**.
8. Once inserted into the hole in the frame channel, hold the Insert in place by firmly grasping the handle on the tool. Turn the Hex Bolt, (tighten), with wrench to expand the Insert in the frame channel, **(Figure 7A)**. Once Insert is fully expanded/compressed, remove the bolt and tool from the Insert, **(Figure 7B)**. **WARNING:** Do not over-tighten or damage to the insert may result.
9. Repeat **Step 4** to assemble the driver side Center Mounting Bracket and Support Bracket. Bolt the Bracket assembly to the 8mm Threaded Insert with (1) 8mm x 30mm Hex Bolt, (1) 8mm Lock Washer and (1) 8mm Flat Washer, **(Figure 8)**. Do not fully tighten hardware at this time.
10. Next, move along the side of the vehicle toward the rear tire opening. Remove the plastic wind deflector attached to the bottom of the body panel, **(Figure 9)**.
11. Locate the factory holes in the bottom of the floor panel in front of the rear suspension mount, **(Figure 10B)**. Select (1) 10mm x 12mm Double Bolt Plate, **(Figure 10A)**. Insert the 10mm side of the Bolt Plate first into the large oval hole and out the smaller round hole, **(Figure 10B)**.
12. Select the driver side Rear Bracket. Attach the rear Bracket to the Bolt Plate with (1) 10mm Flat Washer, (1) 10mm Lock Washer, (1) 10mm Hex Nut, (1) 12mm Flat Washer, (1) 12mm Lock Washer and (1) 12mm Hex Nut, **(Figure 11)**. Do not fully tighten hardware at this time.
13. Select the driver side Rear Support Bracket. Bolt the Support Bracket to the front of the rear Mounting Bracket and on the outside of the pinch weld with (1) 8mm x 20mm Hex Bolt, (2) 8mm Flat Washers and (1) 8mm Nylon Lock Nut, **(Figure 12)**. Leave hardware loose at this time.
14. Carefully unwrap and select the driver side Running Board. Insert (6) 6mm T-Bolts into the slots in the ends of the channels, (3 T-Bolts per slot), on the bottom of the Running Board, **(Figure 13)**. Hold the Running Board up in the approximate position over the Brackets and slide the T-Bolts down the slots to line up with the Brackets. Tilt the Running Board up at a slight angle to clear the slots in the Brackets. Secure the Running Board to the Brackets with (6) 6mm Flat Washers, (6) 6mm Lock Washers and (6) 6mm Hex Nuts, **(Figure 19)**. **NOTE:** The Running Board is designed to fit close to the vehicle. It may be necessary to loosen the (3) Mounting Brackets and tilt the Brackets downward to insert the Running Board. Do not fully tighten hardware at this time.
15. Move to the rear Bracket assembly first. Tighten the hardware securing the Mounting Bracket to the floor panel, **(Figure 11)**. Line up the Support Bracket with the outside of the pinch weld. Mark the location of the hole onto the pinch weld, **(Figure 14)**. **IMPORTANT:** Do not place a mark too close to the edge of the pinch weld. Note that the height of the rear Bracket cannot be adjusted. Adjust the height of the front and center Brackets to match the rear Bracket to properly level the Running Board.
16. Move up to the front Bracket assembly. Tighten the 8mm hardware securing the Bracket to the bottom of the frame channel, **(Figure 4)**. **NOTE:** Use clamps to temporarily hold the front and center Support Brackets in position against the pinch weld as you adjust the height of the Brackets, **(Figure 15)**. Note that if clamps are not available, use a jack, jack stands or blocks to hold the front Brackets up and level with the vehicle.
17. Move to the center Bracket assembly and repeat **Step 16**.

18. Level and adjust the Running Board and tighten the hardware for the front and center Support Brackets. Make sure that the Running Board is level with the vehicle. Mark the hole locations for the front and center Support Brackets onto the pinch weld, (**Figures 14 & 16**). **IMPORTANT:** Do not place a mark too close to the edge of the pinch weld. Adjust the Support Brackets to move the hole away from the edge of the pinch weld. Remove the Running Board.
19. Loosen the hardware and move all of the Brackets out of the way. Remove the complete center Bracket assembly if equipped with plastic cover. Drill (5) 1/4" holes through the pinch weld at the marked locations to bolt the front, center and rear Support Brackets to the pinch weld.
20. Hold the center plastic cover, (if not equipped, skip to **Step 22**), up to the bottom of the vehicle. Locate the center mounting hole, (**see Steps 6 – 8, Figure 18A**). Place a mark 2-1/4" directly in front of the factory hole, (**Figure 17**), to match the location of the threaded insert, (**Steps 6 – 8, Figure 7**). Hold the Support Bracket up in place against the pinch weld. Mark the approximate location of the Support Bracket onto the cover.
21. Line up the Center Bracket with the previous inner and outer marks on the cover and trace the outline of the Bracket onto the cover, (**Figure 18A**). Cut out this section of the cover. **IMPORTANT:** Do not cut through outer edge of the cover, (**Figure 18B**). Only cut enough material from the cover to clear the center Bracket. Reinstall the cover with the factory hardware. Reinstall the center Bracket assembly over the cover.
22. Reinstall the Brackets and Running Board as previously described.
23. Bolt the front, center and rear Support Brackets to the holes drilled through the pinch weld, (**Step 19**), with (5) 6mm x 25mm Hex Bolts, (10) 6mm x 12mm Small Flat Washers and (5) 6mm Nylon Lock Nuts, (**Figure 19**).
24. Level and adjust the Running Board and tighten all hardware.
25. Repeat **Steps 2 – 24** for passenger side Running Board installation.
26. Do periodic inspections to the installation to make sure that all hardware is secure and tight.

To protect your investment, wax this product after installing. Regular waxing is recommended to add a protective layer over the finish. Do not use any type of polish or wax that may contain abrasives that could damage the finish.

For stainless steel: Aluminum polish may be used to polish small scratches and scuffs on the finish. Mild soap may be used also to clean the Running Board.

Driver Side Installation Pictured

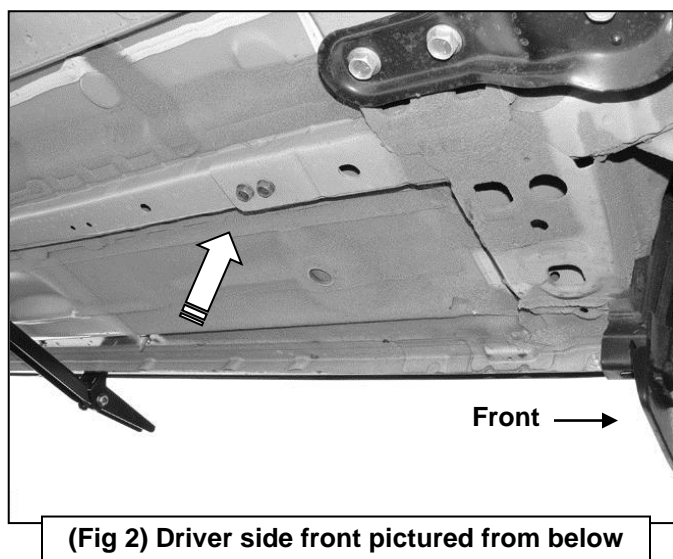
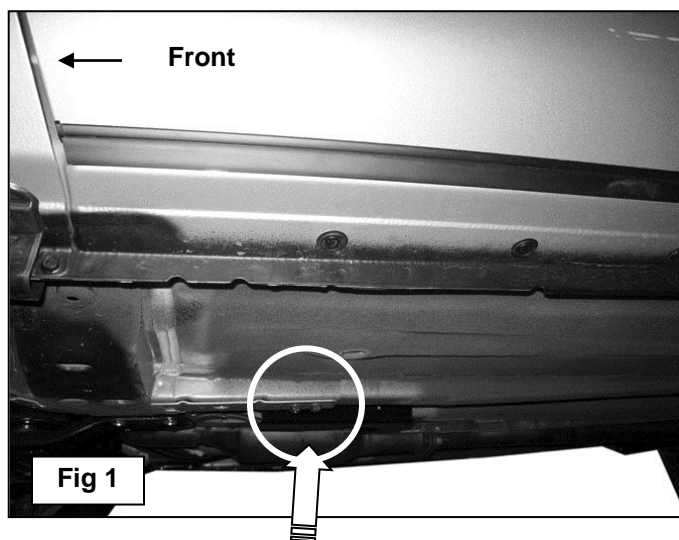

Driver Side Installation Pictured

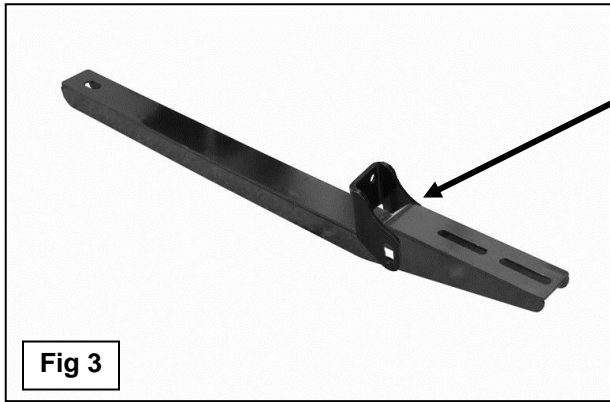

- (2) 8mm x 20mm Hex Bolts
- (4) 8mm Flat Washers
- (2) 8mm Nylon Lock Nuts

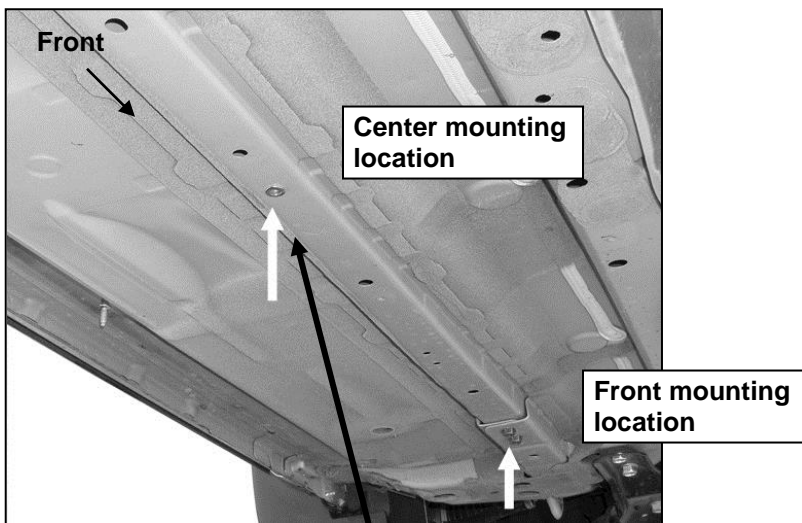
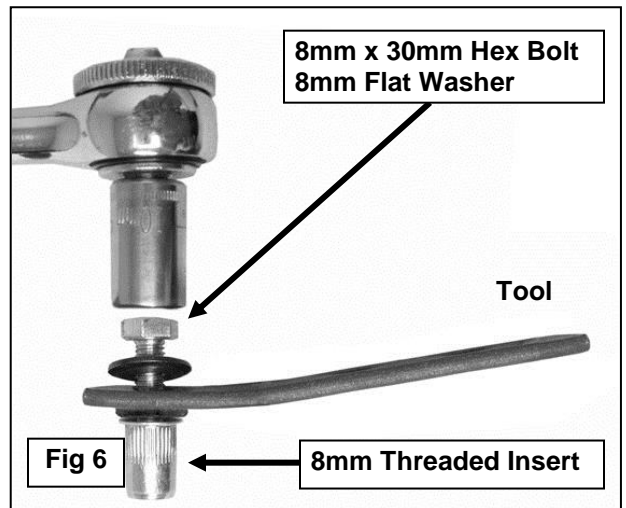
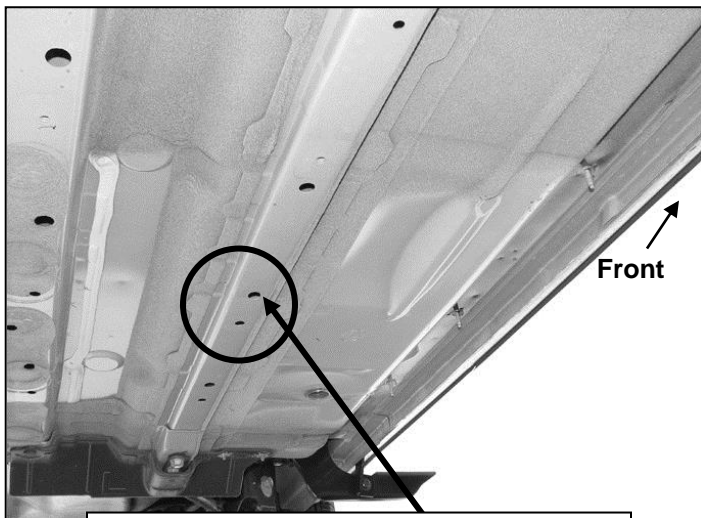
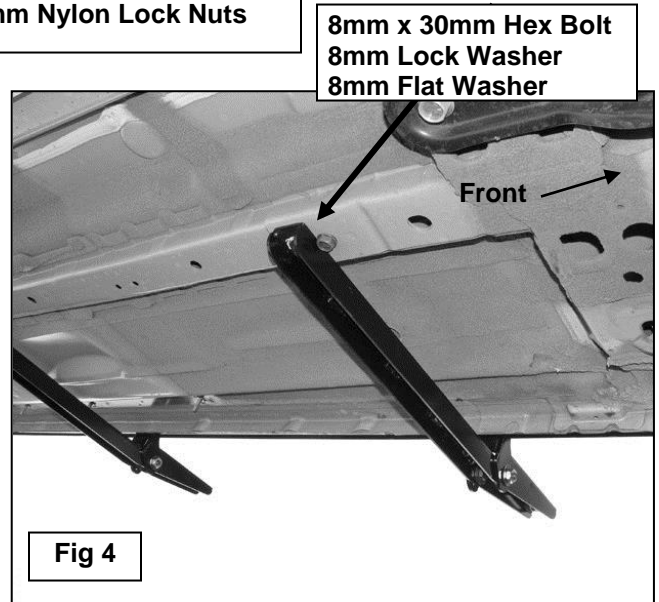

(Fig 7A) Threaded Insert fully installed.
Pictured from below looking forward



Driver Side Installation Pictured

8mm x 30mm Hex Bolt
8mm Lock Washer
8mm Flat Washer

(2) 8mm x 20mm Hex Bolts
(4) 8mm Flat Washers
(2) 8mm Nylon Lock Nuts

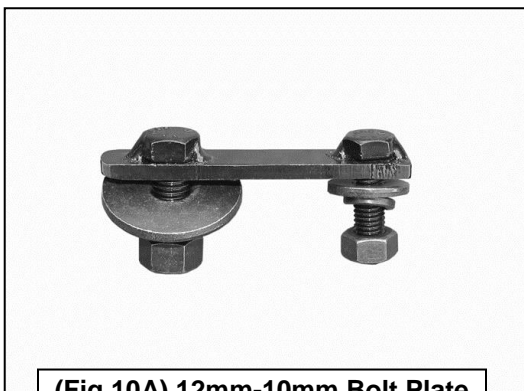
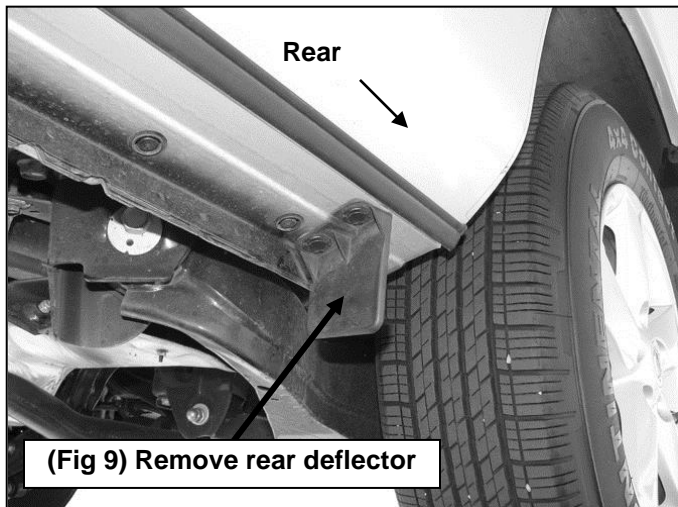
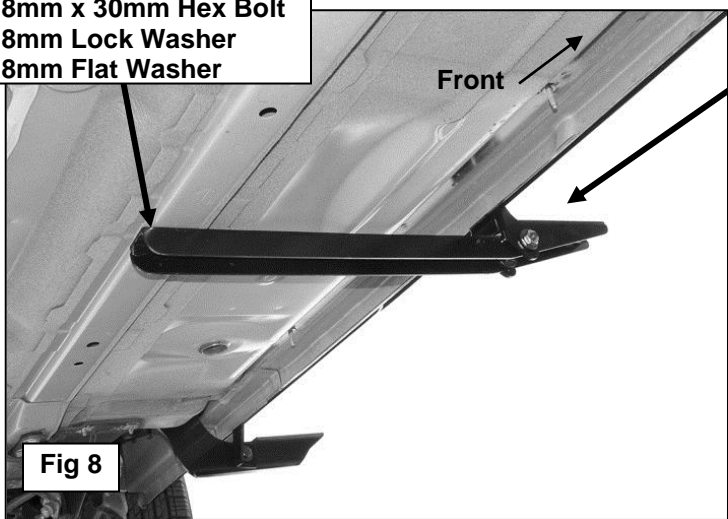

10mm Flat Washer
10mm Lock Washer
10mm Hex Nut

12mm Flat Washer
12mm Lock Washer
12mm Hex Nut

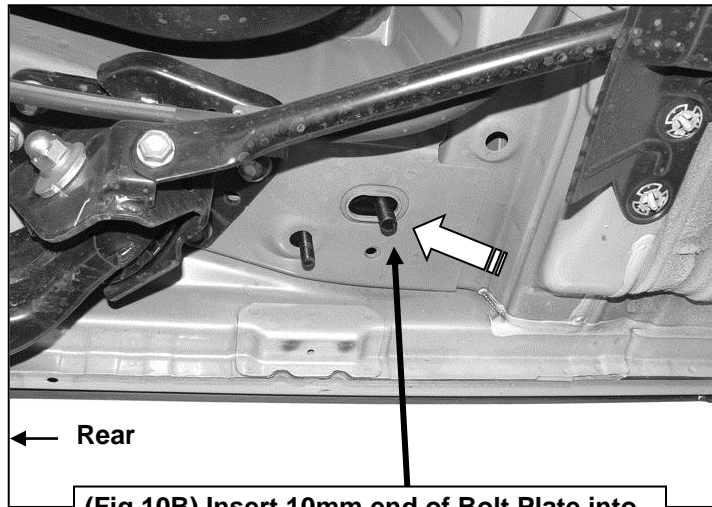
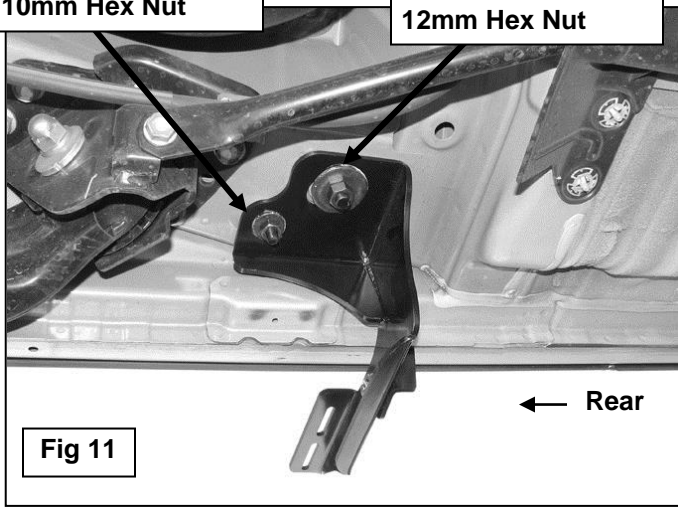

Driver Side Installation Pictured

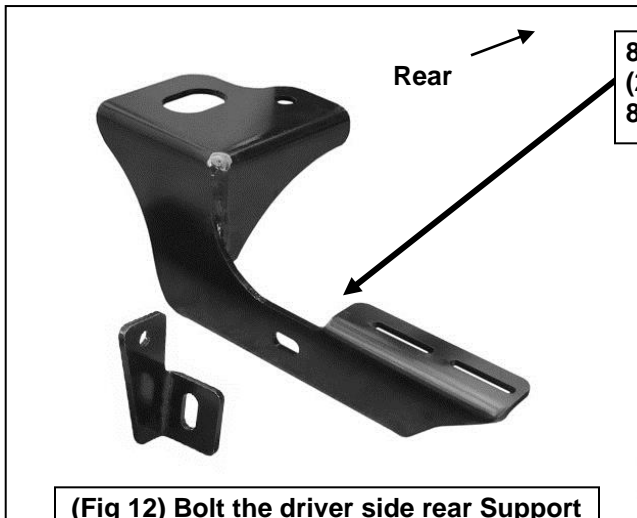

8mm x 20mm Hex Bolt
(2) 8mm Flat Washers
8mm Nylon Lock Nut

(Fig 12) Bolt the driver side rear Support Bracket to the front of the rear Bracket

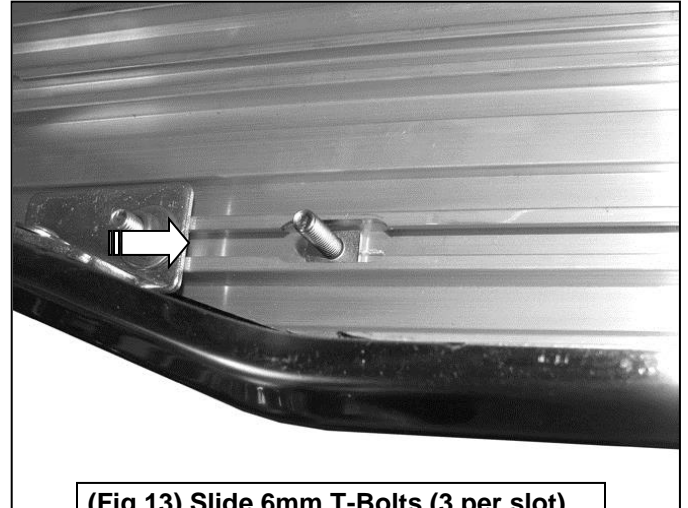

(Fig 13) Slide 6mm T-Bolts (3 per slot) into slots on bottom of Running Board

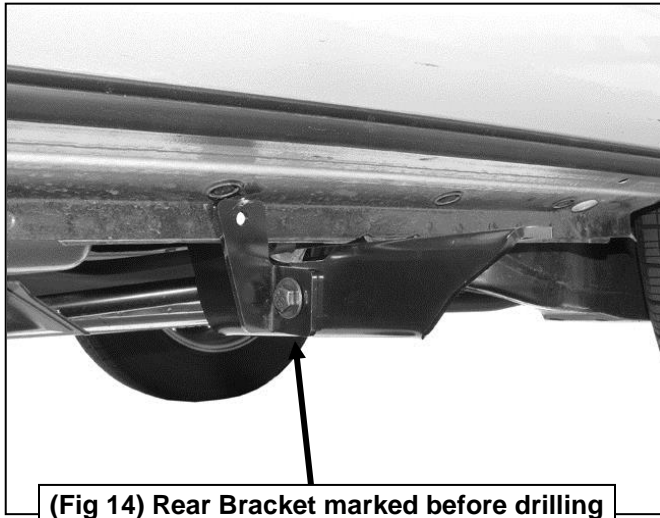

(Fig 14) Rear Bracket marked before drilling

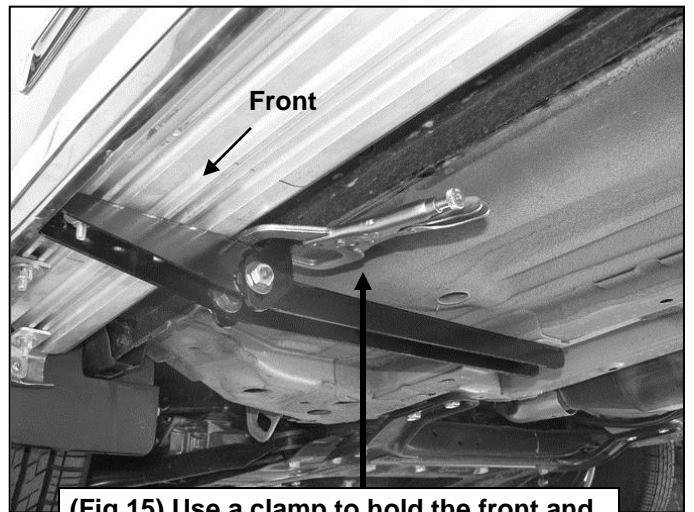

(Fig 15) Use a clamp to hold the front and center Brackets up to the pinch weld

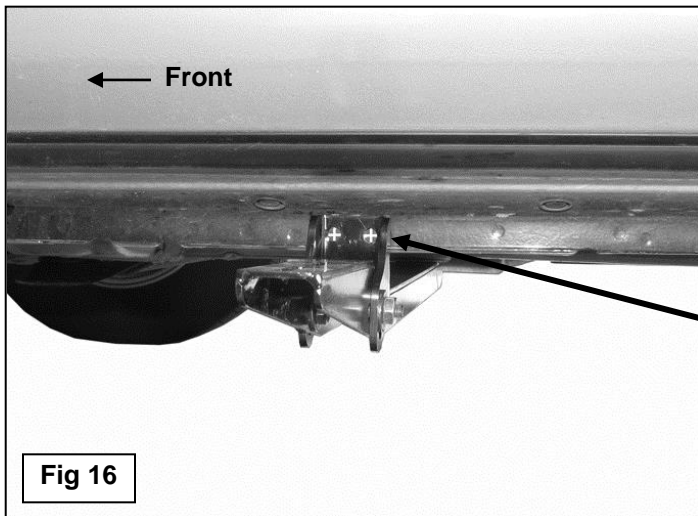
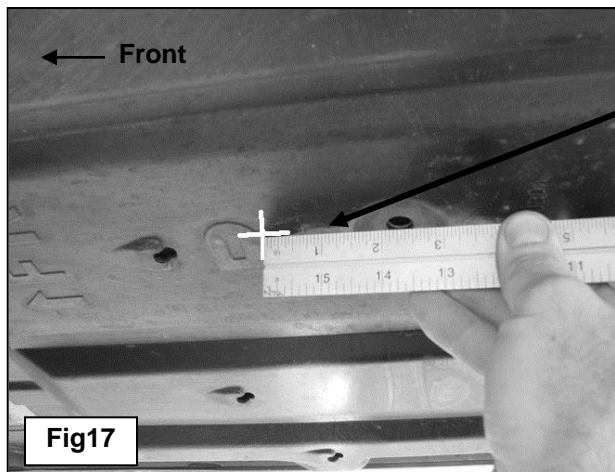

Fig 16

Once level, mark the front and center Support Bracket locations onto the pinch weld. Remove the Running Board before drilling. Also remove the center Bracket assembly

Driver Side Installation Pictured



Hold the plastic cover back up in position, (if equipped). Locate the center mounting hole. Measure 2-1/4" forward of the center mounting hole. This should match up to the previously installed 8mm Threaded Insert

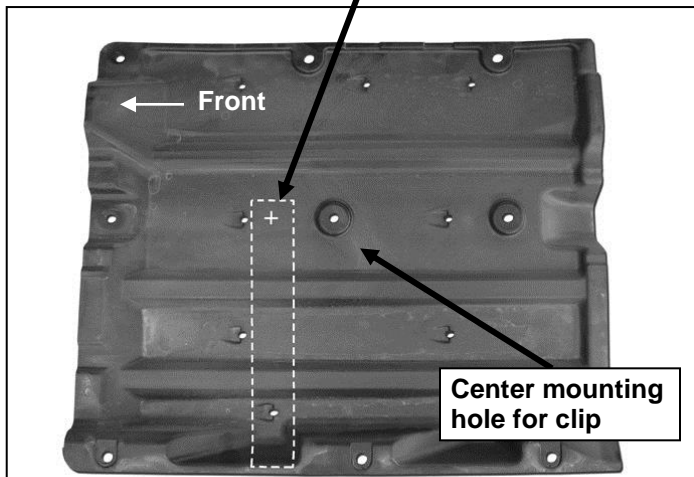

(Fig 18A) Inside of the driver side plastic cover pictured for example only. Actual cover may be different depending on model and year

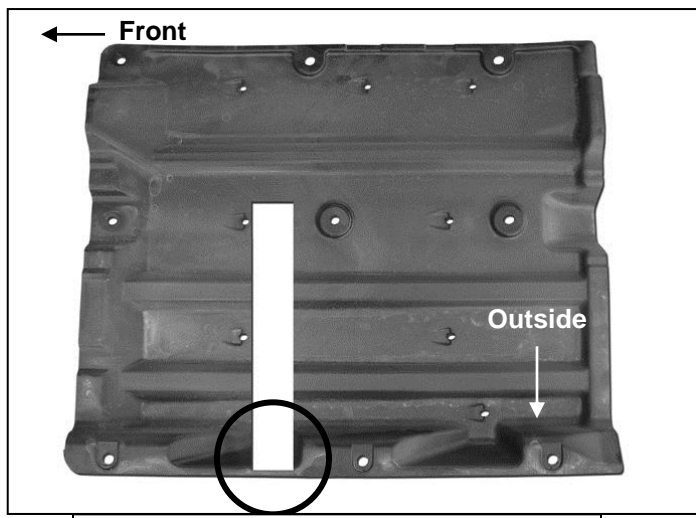

(Fig 18B) Cut a slot the approximate width of the Mounting Brackets. Do not cut through outer top edge of cover

All Support Brackets to pinch weld use:
6mm x 20mm Hex Bolt
(2) 6mm x 12mm Small Flat Washers
6mm Nylon Lock Nut

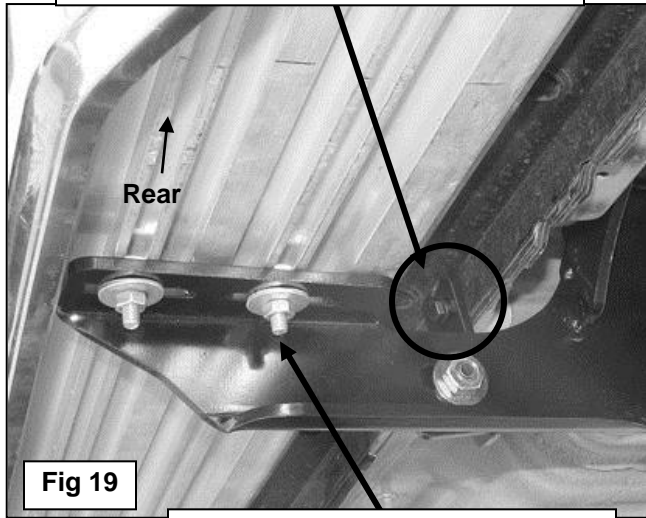

(2) 6mm x 22 Large Flat Washers
(2) 6mm Lock Washers
(2) 6mm Hex Nuts

