

**VIEWPOINT ALUMINUM RUNNING BOARD  
2006 - 13 TOYOTA RAV4**

**PARTS LIST:**

1	Driver/Left Running Board	4	10-1.5mm x 50mm T-Bolt
1	Passenger/Right Running Board	12	10mm Plastic Retainers
1	Driver/Left Front Bracket	2	10-1.50mm x 40mm Hex Bolt
1	Passenger/Right Front Bracket	2	10-1.50mm x 30mm Hex Bolts
1	Driver/Left Front Support Bracket	8	10mm x 27mm OD x 3mm Large Flat Washers
1	Passenger/Right Front Support Bracket	8	10mm x 24mm OD x 2.2mm STD Flat Washer
1	Driver/Left Center Bracket	2	10-1.50mm Hex Nut
1	Passenger/Right Center Bracket	14	10-1.50mm Nylon Lock Nuts
1	Driver/Left Center Mounting Bracket	4	8-1.25mm x 30mm Hex Bolts
1	Passenger/Right Center Mounting Bracket	8	8mm x 16mm OD x 1.6mm Flat Washers
1	Driver/Left Rear Bracket	4	8-1.25mm Nylon Lock Nuts
1	Passenger/Right Rear Bracket	12	6-1.0mm x 20mm T-Bolts
2	Surface Reinforcement Plate	12	6mm x 22mm OD x 2mm Flat Washers
8	10-1.5mm x 62mm Bolt Plates	12	6mm Lock Washers
4	Locking Plate (for Bolt Plates)	12	6mm Hex Nuts

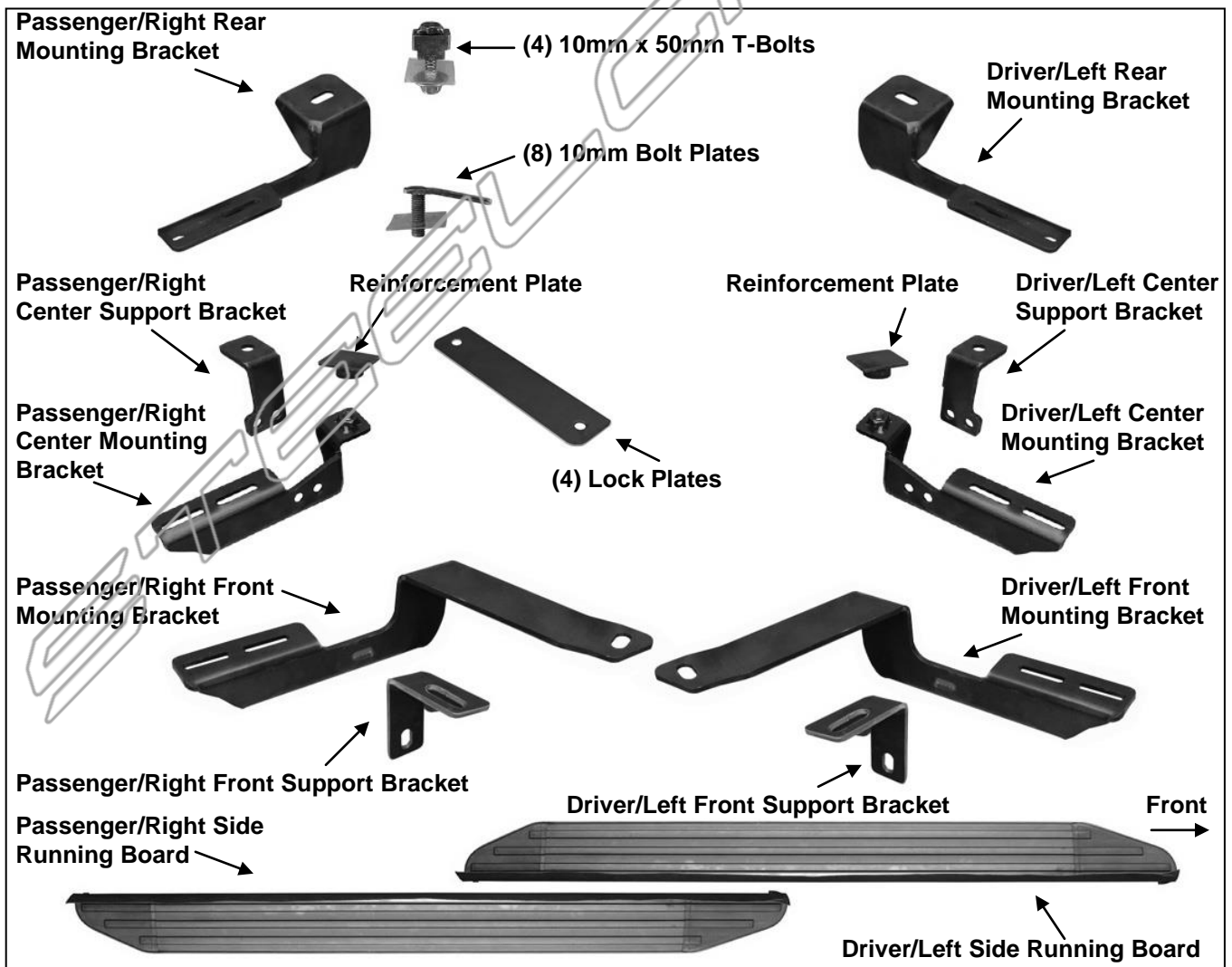

PROCEDURE:

1. REMOVE CONTENTS FROM BOX. VERIFY ALL PARTS ARE PRESENT. READ INSTRUCTIONS CAREFULLY BEFORE STARTING INSTALLATION.
2. Starting on the driver side of the vehicle, locate and remove the factory oval rubber plug, **(Figure 1)**. Remove the (2) round rubber plugs in the bottom of the floor panel located closest to the front tire opening. Select (1) T-Bolt and (1) 10mm Plastic Retainer, **(Figure 2A)**. Insert the T-Bolt up into the oval hole and rotate it 90-degrees so that the block is across the oval hole. Thread the Plastic Retainer onto the T-Bolt and tight against the floor panel, **(Figure 2B)**. **NOTE:** The Plastic Retainer is designed to help hold the T-Bolt in place during Bracket installation.
3. Next, select (2) 10mm x 35mm Bolt Plates and (2) 10mm Plastic Retainers. Thread (1) Retainer part way onto the each Bolt Plate, **(Figure 3A)**. Insert (1) Bolt Plate into each round hole in the floor panel next to the pinch weld, **(Figure 3B)**. **IMPORTANT:** Install the Bolt Plates with the "Plates" pointing toward each other, **(Figure 4)**. Thread the Retainer down tight against the floor panel. Select (1) Front Lock Plate. Slide the Lock Plate over the (2) Bolt Plates. Secure the Lock Plate to the rear Bolt Plate only with (1) 10mm Flat Washer, (1) 10mm Lock Washer and (1) 10mm Hex Nut, **(Figure 5)**. Leave hardware loose.
4. Select the driver side Front Bracket. Secure the Front Bracket to the T-Bolt with (1) 10mm x 27mm Large Flat Washer and (1) 10mm Nylon Lock Nut, **(Figure 6)**. Do not tighten the Lock Nut at this time.
5. Slide the driver side "L" Front Support Bracket onto the 10mm x 35mm Bolt Plate and over the Lock Plate, **(Figure 7A)**. Secure the Bracket to the Bolt Plate with (1) 10mm x 24mm STD Flat Washer and (1) 10mm Nylon Lock Nut, **(Figure 7B)**. Leave hardware loose. Line up the slot in the "L" Front Support Bracket with the slot in the Front Mounting Bracket. Bolt the Support Bracket to the front of the Mounting Bracket with (1) 10mm x 30mm Hex Bolt, (2) 10mm x 24mm STD Flat Washers and (1) 10mm Nylon Lock Nut, **(Figure 7B)**. Snug but do not fully tighten hardware at this time.
6. Move along the side of the vehicle to the center location below where the front and rear doors meet. Locate the 4th and 5th hole in the floor panel from the front wheel opening, **(Figure 8)**. Remove the (2) rubber plugs. Insert (2) 10mm x 35mm Bolt Plates with (2) 10mm Plastic Retainers, **(Figure 9A)**, as described in **Step 3**, **(Figures 9A & 9B)**. **IMPORTANT:** Install the Bolt Plates with the "Plates" pointing toward each other, **(see Figure 4)**. Slide (1) Lock Plate over the (2) Bolt Plates. Attach the Lock Plate to the forward Bolt Plate with (1) 10mm Flat Washer and (1) 10mm Nylon Lock Nut, **(Figure 10)**. Hang the Center Support Bracket from the Bolt Plate with (1) 10mm x 24mm STD Flat Washer and (1) 10mm Nylon Lock Nut, **(Figures 11 & 12)**. Do not tighten hardware at this time.
7. Select the Center Mounting Bracket, (1) 10mm x 40mm Hex Bolt, (1) 10mm Regular Hex Nut and (1) Reinforcement Plate, **(Figure 11)**. Thread the 10mm Hex Nut all the way down the 10mm x 40mm Hex Bolt. Insert the Hex Bolt with Nut up and into the welded nut on the tab on the Center Bracket, **(Figure 11)**. **NOTE:** Thread the Bolt in until a few threads are sticking out of the welded nut. Do not thread the hex bolt all of the way into the welded nut. Bolt the Center Bracket to the front side of the Center Support Bracket with (2) 8mm x 30mm Hex Bolts, (4) 8mm Flat Washers and (2) 8mm Nylon Lock Nuts, **(Figure 12)**. Leave hardware loose at this time. Place (1) Reinforcement Plate onto the threaded end of the 10mm x 40mm Hex Bolt, **(Figure 11)**. Continue to thread the Hex Bolt in until the Reinforcement Plate is close to but not touching the bottom of the body panel. Snug but do not tighten the 8mm mounting hardware. **IMPORTANT:** Do not tighten the hardware on the Center Brackets until the final Steps, **(see Steps 13 – 14)**.
8. Move along the vehicle to the rear mounting location, **(Figure 13)**. Remove the oval rubber plug. Select (1) T-Bolt and (1) 10mm Plastic Retainer, **(Figure 14A)**. Insert the T-Bolt up into the oval hole and rotate 90-degrees so that the block is across the oval hole. Thread the Plastic Retainer onto the T-Bolt and tight against the floor panel as described in **Step 2**, **(Figure 14B)**.
9. Select the driver side Rear Mounting Bracket. Hang the Rear Bracket from the T-Bolt with (1) 10mm x 27mm Large Flat Washer and (1) 10mm Nylon Lock Nut as described in **Step 4**, **(Figure 15)**. Snug but do not tighten the 10mm Lock Nut on the rear Bracket.
10. Carefully unwrap the driver side Running Board. From the front, slide (3) T-Bolts into each channel in the bottom of the Running Board, **(Figure 16)**. Slide the T-Bolts forward or back to line up with the slots in the (3) previously installed Mounting Brackets. Hold the Running Board up to the vehicle at a slight

**VIEWPOINT ALUMINUM RUNNING BOARD  
2006 - 13 TOYOTA RAV4**

angle and gently push it into position against the rocker panel. Insert the T-Bolts through the slots in the Brackets, **(Figure 17)**.

11. Attach the Running Board to the (3) Mounting Brackets with the included (6) 6mm Flat Washers, (6) 6mm Lock Washers and (6) 6mm Hex Nuts, **(Figure 17)**. Do not tighten hardware at this time.
12. Check to see if the Running Board is level to the car, front to rear, not level to the ground. Adjust the Brackets in or out as necessary to line up the Running Board with the side of the vehicle. Move to the rear Bracket and once aligned, tighten the 10mm Hex Nut on the T-Bolt, **(Figure 15)**.
13. Next, move to the front Bracket. Tighten the T-Bolt and Bolt Plate hardware only, **(Figures 6 & 7B)**. Adjust the height of the front Bracket as necessary. Once properly adjusted, tighten the 10mm Hex Bolt securing the Support Bracket to the front Mounting Bracket, **(Figure 7B)**.
14. With the front and rear Brackets fully tightened to the vehicle, move to the Center Bracket, **(Figure 18)**. Fully tighten the 10mm Lock Nut securing the Support Bracket to the Bolt Plate, **(Figure 18)**. Gently push the Mounting Bracket up against and level to the bottom of the Running Board. Tighten the (2) 8mm Hex Bolts. Slowly tighten the 10mm x 40mm Hex Adjustment Bolt until the Reinforcement Plate is snug against the bottom of the body panel. Turn the Hex Bolt (2) full turns tighter to add preload. Tighten the 10mm Hex Nut to lock the Bolt in place, **(Figure 18)**.
15. At this point, all Bracket hardware should be fully tightened. Check for front to back adjustment on the Running Board and tighten all Running Board to Bracket hardware, **(Figure 17)**.
16. Repeat **Steps 2 – 15** for the passenger side Running Board installation.
17. Do periodic inspections to the installation to make sure that all hardware is secure and tight.

**To protect your investment**, wax this product after installing. Regular waxing is recommended to add a protective layer over the finish. Do not use any type of polish or wax that may contain abrasives that could damage the finish.

**For stainless steel:** Aluminum polish may be used to polish small scratches and scuffs on the finish. Mild soap may be used also to clean the Running Board.

**For gloss black finishes:** Mild soap may be used to clean the Running Board Brackets.

**Driver Side Installation Pictured**

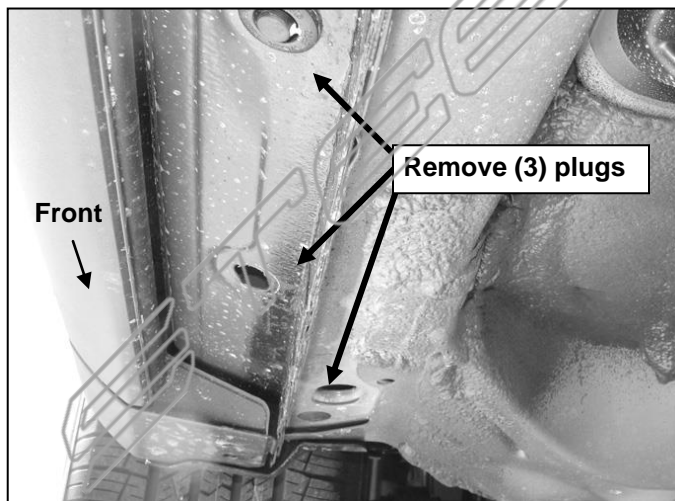

**(Fig 1) Driver side front mounting location pictured**



**(Fig 2A) 10mm T-Bolt**

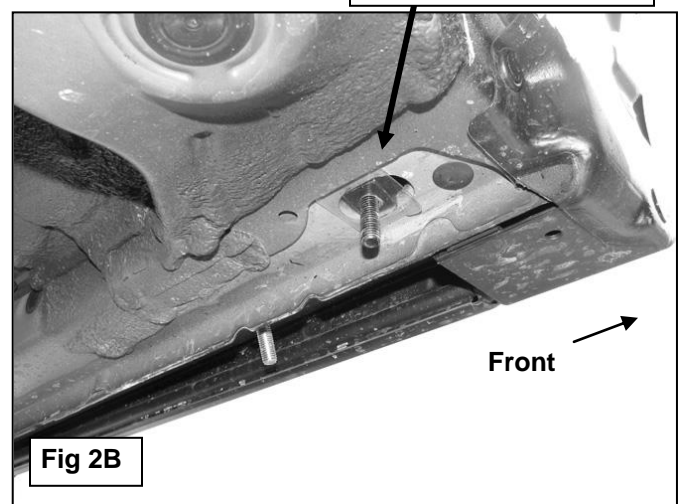

**Fig 2B**

Driver Side Installation Pictured

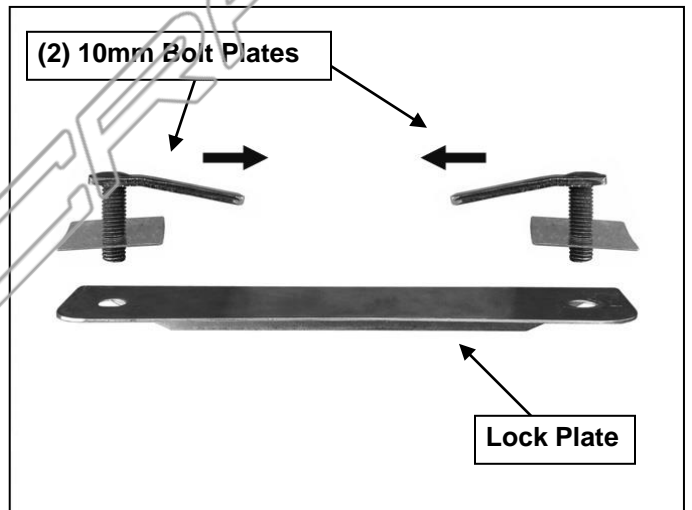
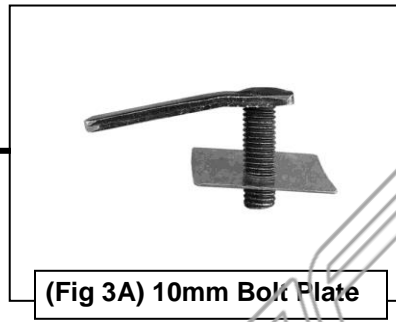
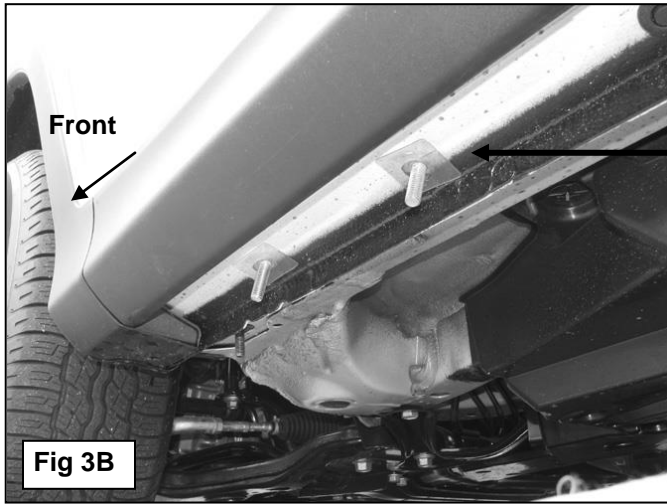

(Fig 4) Install Bolt Plates with Plates pointing towards each other

10mm x 24mm STD Flat Washer  
10mm Nylon Lock Nut

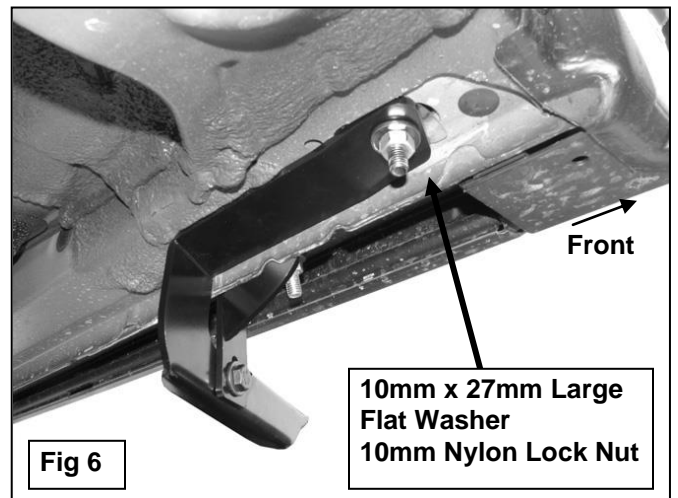
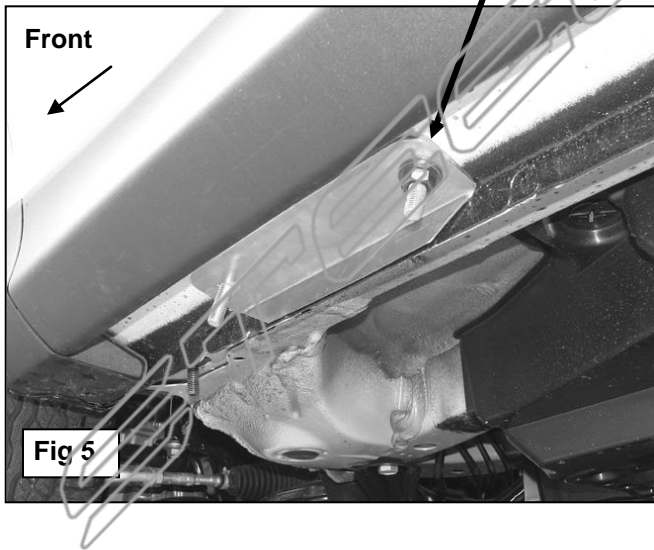

Driver Side Installation Pictured

10mm x 24mm STD  
Flat Washer  
10mm Nylon Lock Nut

10mm x 30mm Hex Bolt  
(2) 10mm x 24mm STD  
Flat Washers  
10mm Nylon Lock Nut

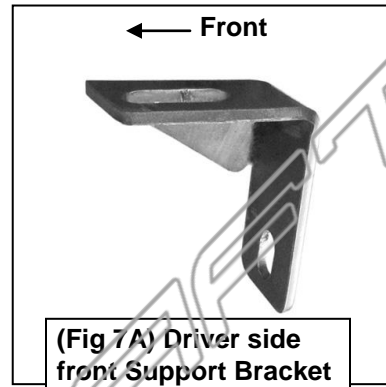
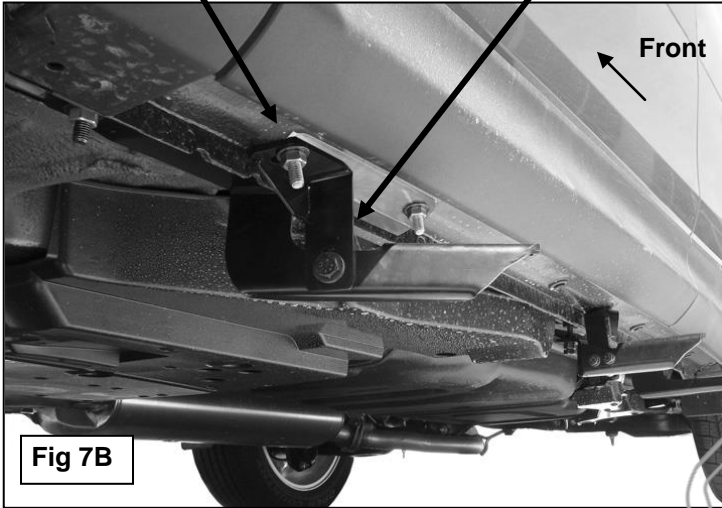

Locate the 4th and 5th rubber plugs along the floor panel back from the front fender opening

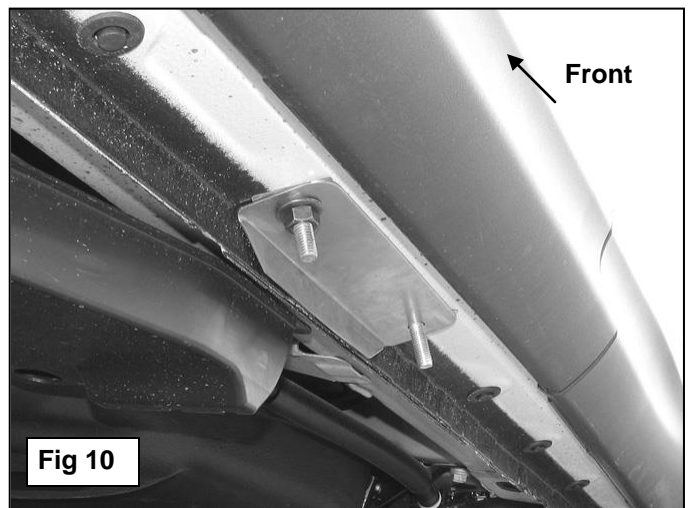
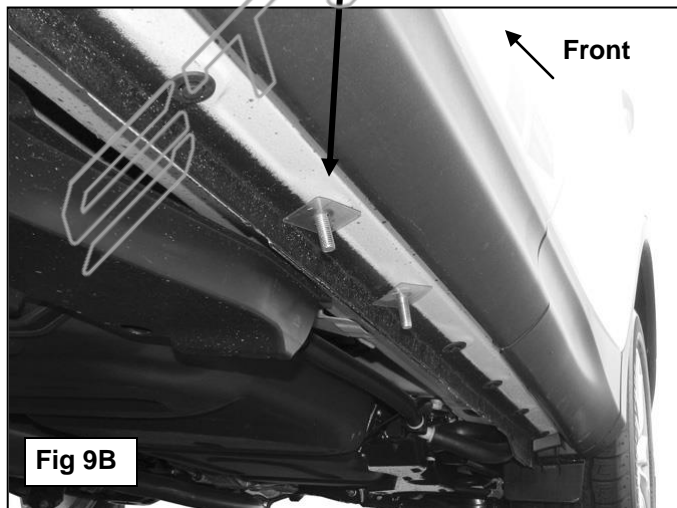
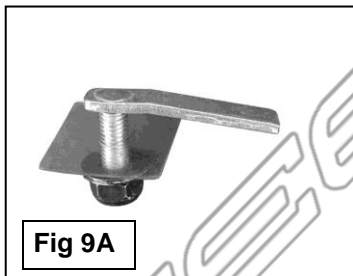
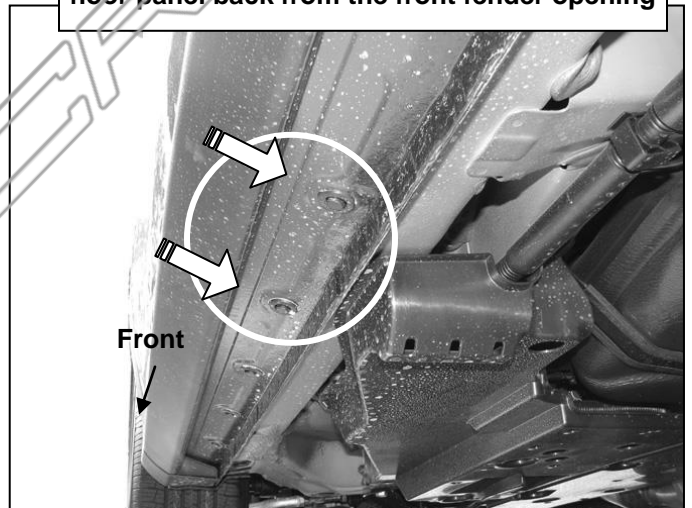

Driver Side Installation Pictured

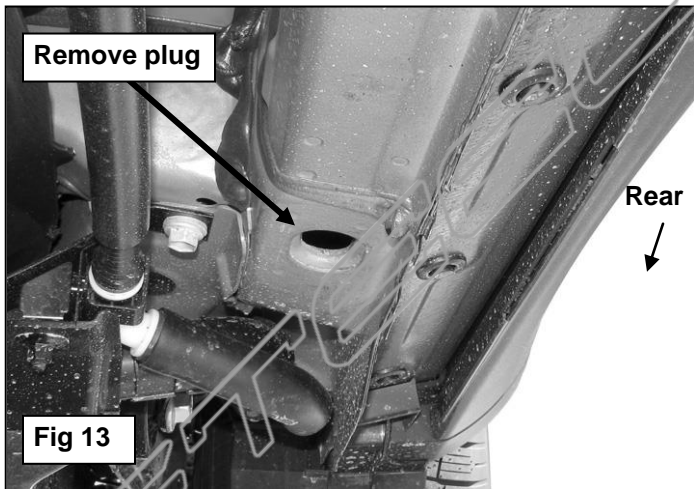
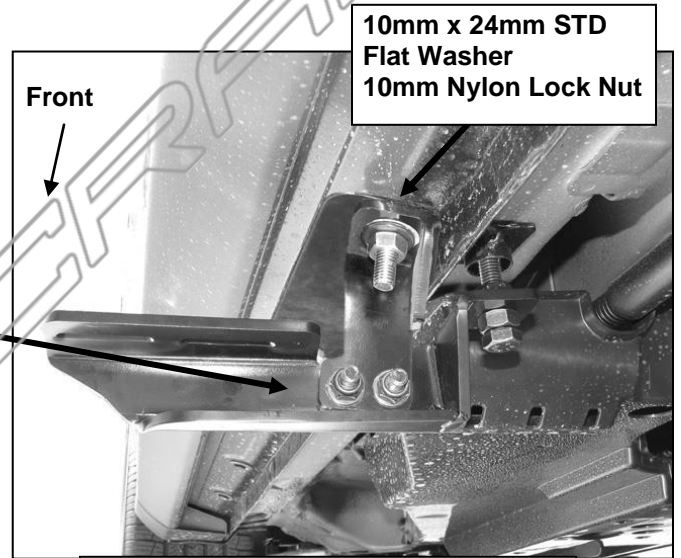
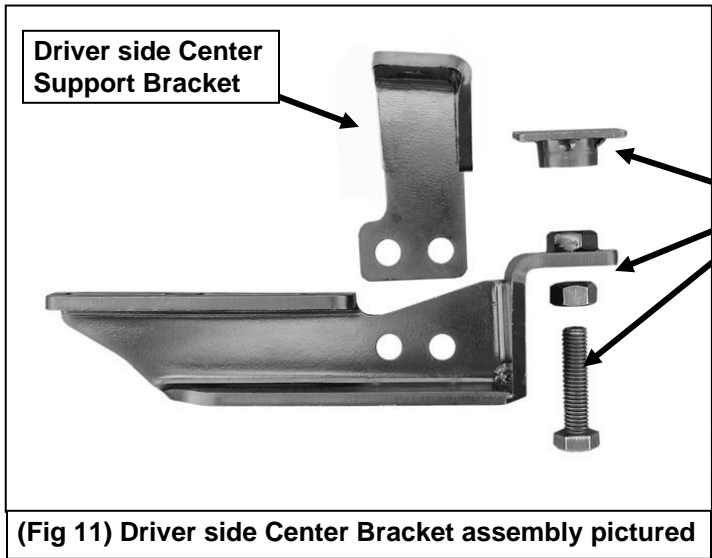

- (2) 8mm x 30mm Hex Bolts
- (4) 8mm Flat Washers
- (2) 8mm Nylon Lock Nuts

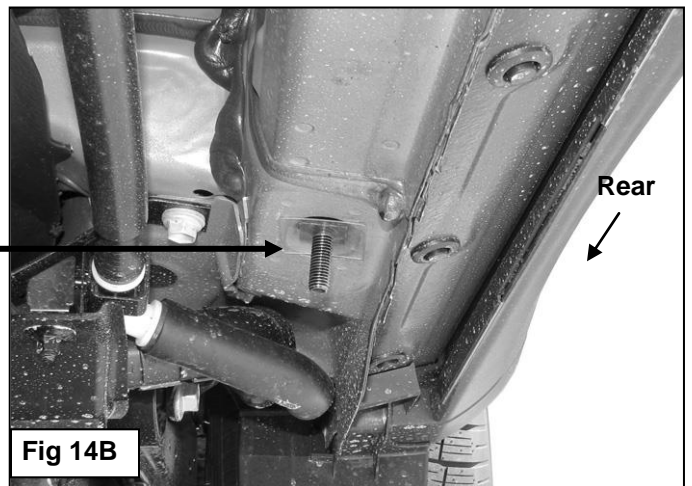

Driver Side Installation Pictured

10mm x 27mm Large Flat Washer  
10mm Nylon Lock Nut

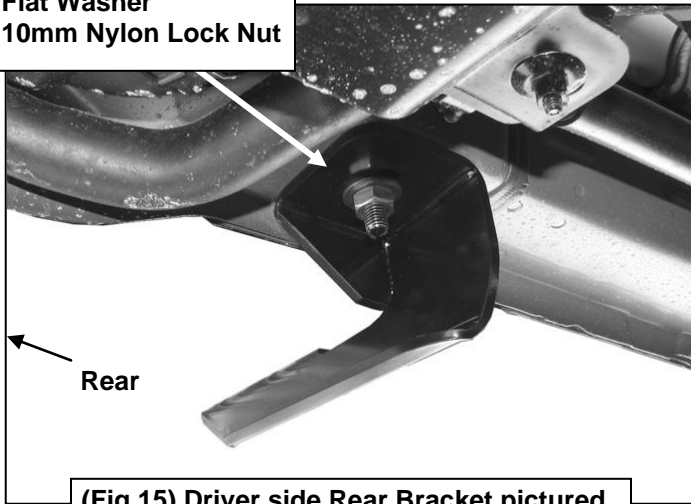

(Fig 15) Driver side Rear Bracket pictured

Slide T-Bolts into slot at front end of Running Board

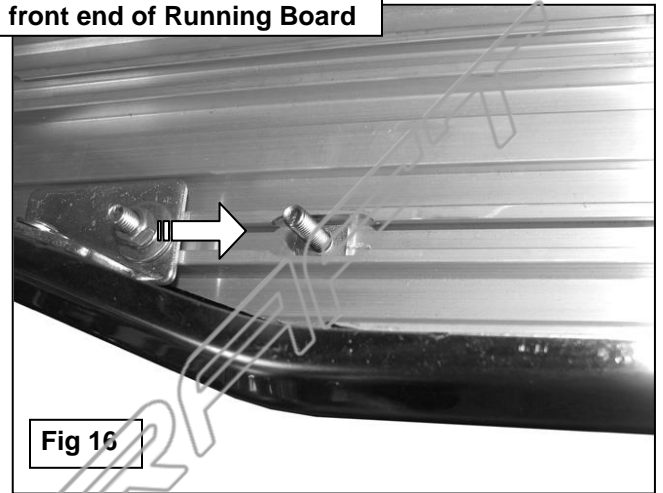
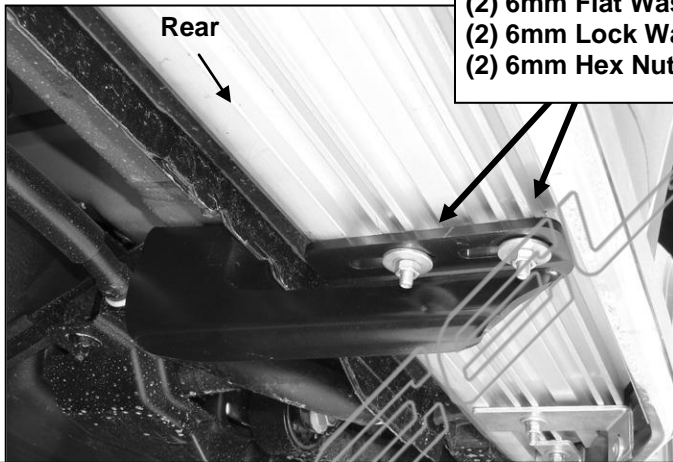
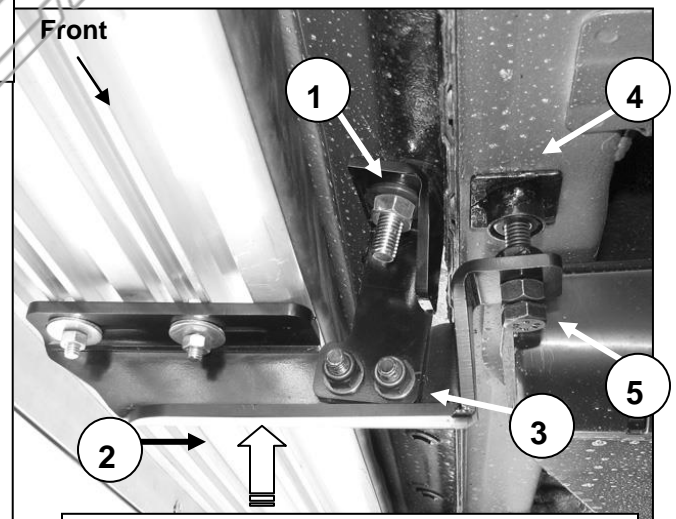

Fig 16

(2) 6mm Flat Washers  
(2) 6mm Lock Washers  
(2) 6mm Hex Nuts



(Fig 17) Tilt the Running Board up and push back into position against rocker panel. Loosen Brackets if necessary. Line up T-Bolts with slots in Brackets



(Fig 18) Driver side Center Bracket pictured

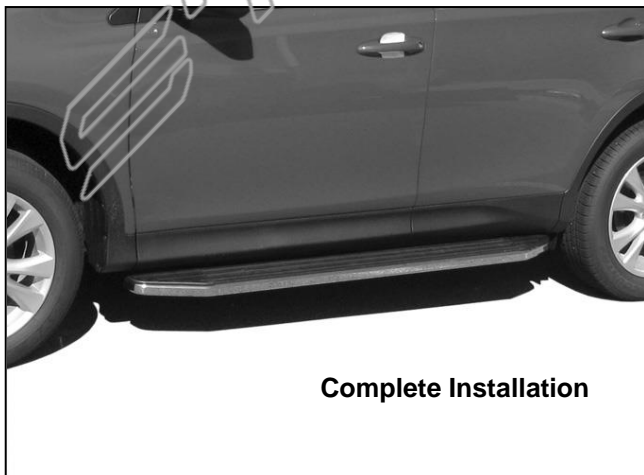

Complete Installation

Once the Running Board has been aligned and the front and rear brackets fully tightened:

1. Tighten the 10mm Bolt Plate hardware
2. Hold the Bracket level and against the bottom of the Running Board
3. Tighten the (2) 8mm Hex Bolts
4. Tighten the 10mm x 40mm Hex Bolt until the Reinforcement Plate is snug up against the floor panel
5. Turn Hex Bolt 1/2 to 1 full turn and tighten jam nut to lock adjustment. Readjust as necessary