

**HD**  
**MOMENTUM™**

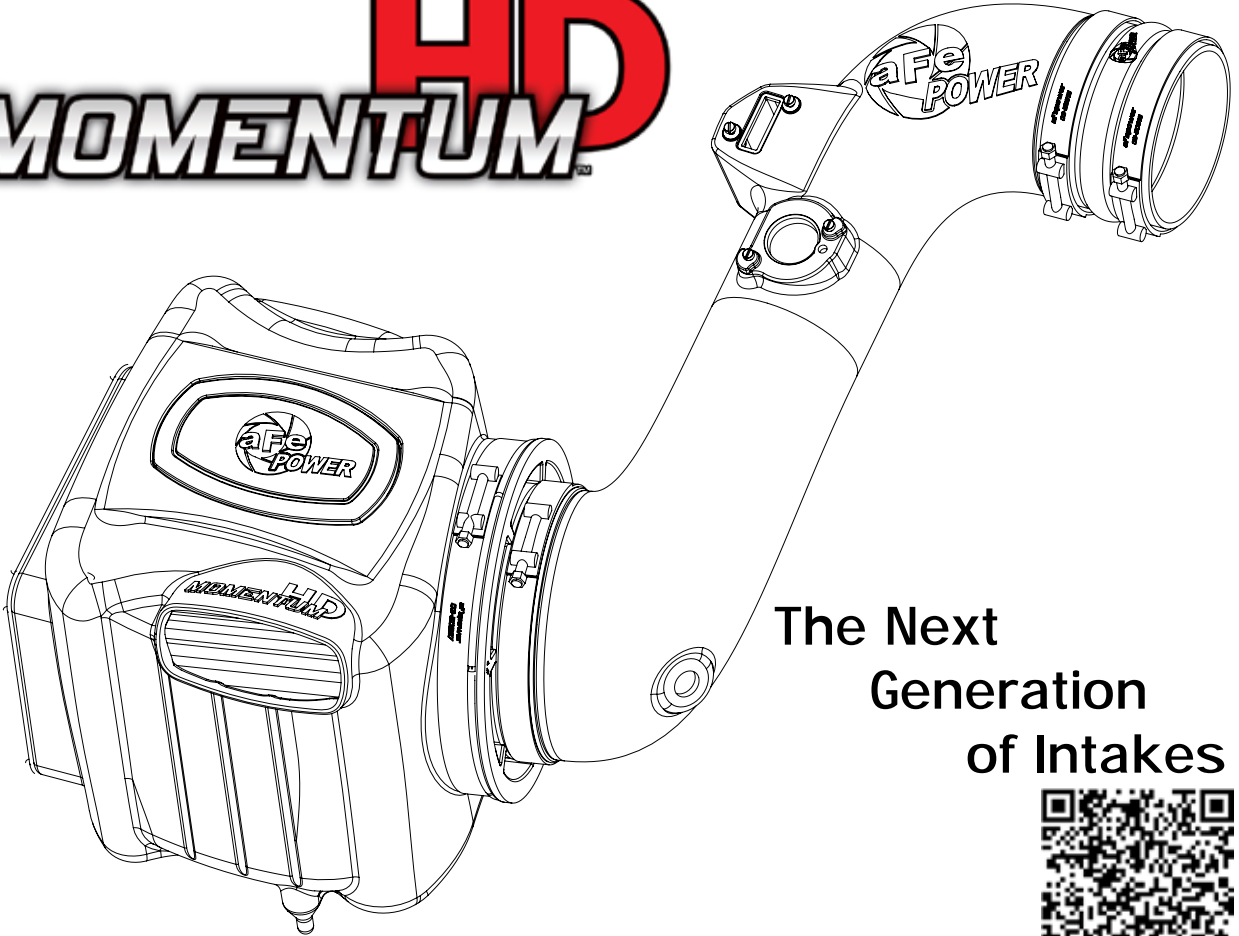

The Next  
Generation  
of Intakes



**advanced FLOW engineering**

**Instruction Manual** P/N: 50-74006-1/ 51-74006-1

Make: **GM** Model: **Silverado HD/Sierra HD** Year: **2011-2016** Engine: **V8-6.6L (td) LML**



- Please read the entire instruction manual before proceeding.
- Ensure all components listed are present.
- If you are missing any of the components, call customer support at 951-493-7100 or e-mail at tech@afepower.com.
- Ensure you have all necessary tools before proceeding.
- Do not attempt to work on your vehicle when the engine is hot.
- Disconnect the negative battery terminal before proceeding.
- Retain factory parts for future use.

Label	Qty.	Description	Part Number
A	1	Seal, Trim: 7/16" (26"L)	05-00072
B	1	Housing	05-82302B2
C	1	Plug, Urethane	05-01202
D	1	Clamp, T-bolt (8-5/16")	03-50267
E1	1	PRO 10R (Blue Media)	20-91059
E2	1	PRO DRY S (Grey Media)	21-91059
F	1	Tube	05-74006B1
G	1	Gasket	05-00631
H	1	Block Off Plate	05-01372
I	2	Screw, M4 x 12mm	03-50455
J	4	Screw, Torx: M4 x .7 x 8mm	03-50491
K	2	Clamp, T-Bolt (4-7/16")	03-50319
L	1	Coupling, Silicone Dbl. Hump	05-01430
M	1	Cap	03-50103
N	1	Grommet	03-50033

Installation will require the following tools:  
8mm Nut driver, 10mm Nut driver and Torx (T-20) driver.

**Note:** Legal in California for use on race vehicles only. The use of this device on vehicles used on public streets or highways is strictly prohibited in California and others states that have adopted California emission regulations.

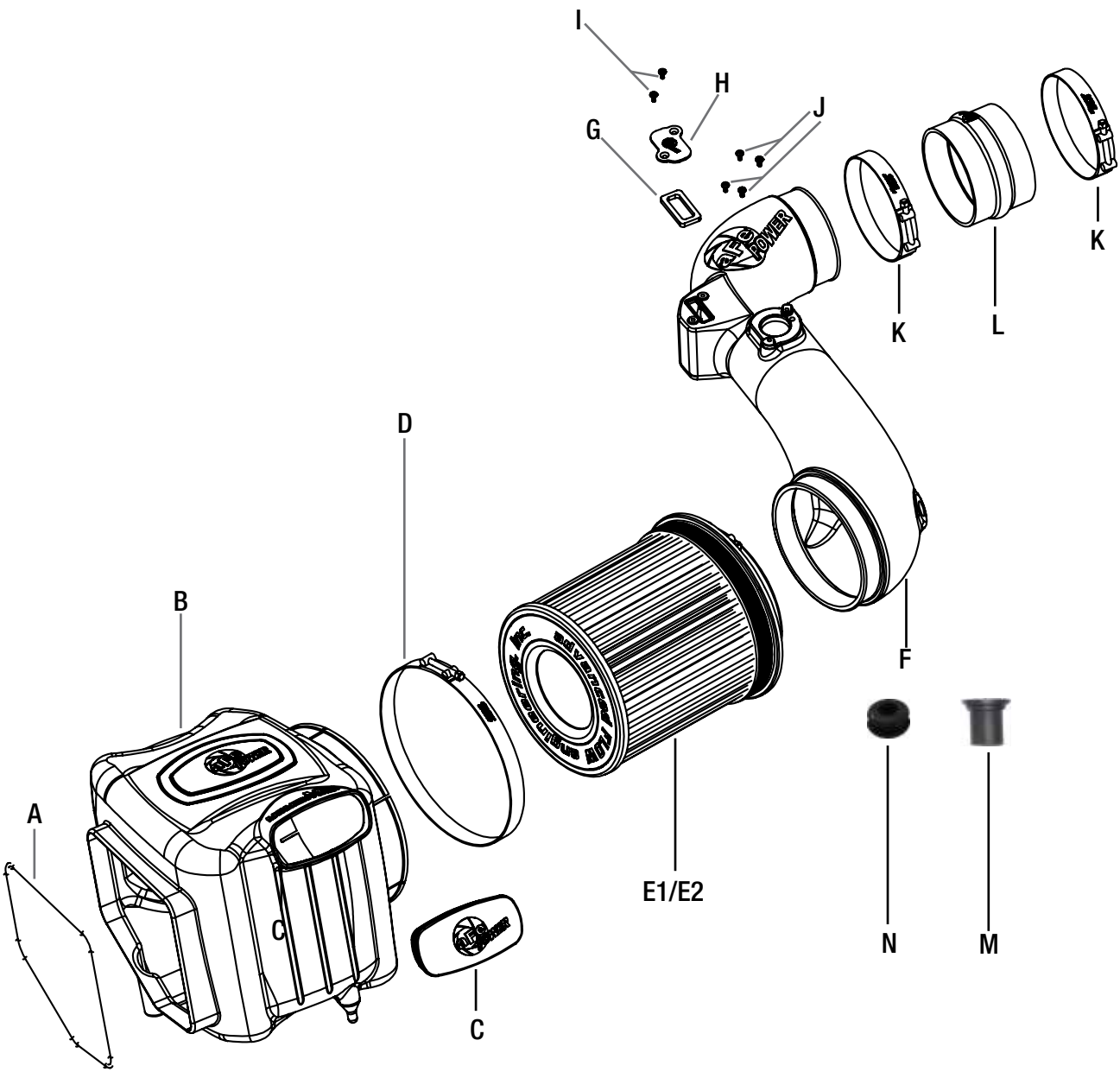



REMOVAL

Figure A

**Refer to Figure A for steps 1-3**

Step 1: Disconnect Mass Air Flow Sensor (1), Temperature Sensor (2) and Humidity Sensor (3).

Step 2: Loosen all tube clamps using a 8mm nut driver.

Step 3: Remove the factory intake tube and air box out of the vehicle. (Use an upward pull to release the air box from its mounting grommets).



Figure B

**Refer to Figure B for step 4**

Step 4: Slide the aFe filter into the air box. Install furnished T-bolt clamps. **Do not tighten at this time.**

**IMPORTANT:** Prior to installation of T-Bolt clamp, we recommend that you stretch the T-Bolt clamps by installing it in its intended position and tightening.



Figure C

**Refer to Figure C for steps 5-7**

Step 5: Install the trim seal on edge of the aFe air box (3).

Step 6: Remove the retaining plug (4) from the bottom of the factory air box.

Step 7: Install the plug on the aFe air box.



Figure D

**Refer to Figure D for step 8**

Step 8: Install the Momentum HD air box into the vehicle. Firmly push it into the factory mounting grommets.

**Figure E****Refer to Figure E for steps 9-13**

- Step 9: Remove Mass Air Flow Sensor and Humidity Sensor from the factory air box using a Torx (T-20) driver.
- Step 10: Install Mass Air Flow Sensor and Humidity Sensor (use factory gasket for Humidity Sensor) into the Momentum HD intake tube using supplied M4 screws. If vehicle does not have the humidity sensor, use the supplied gasket, M4x 12mm flathead screws, and block off plate to seal opening.
- Step 11: Remove the filter minder and grommet from factory air box.
- Step 12: Install factory grommet into Momentum HD intake tube, then firmly press filter minder into it. If your vehicle is not equipped with a filter minder, just plug off the hole with the provided grommet and cap.
- Step 13: Install furnished silicone hump coupler and T-bolt clamps on the aFe tube. **Do not tighten clamps at this time.**





Figure F

**Refer to Figure F for steps 14-15**

Step 14: Install the Momentum HD tube into the vehicle. Slide the coupling in the turbo inlet tube first. Then rotate the tube down and slide it into the filter.

Step 15: Tighten all clamps.



Figure G

**Refer to Figure G for steps 16-17**

Step 16: Re-connect the Mass Air Flow Sensor and Humidity Sensor. Re-connect the temperature sensor by routing harness across the intake tube.

Step 17: Check all the components are tight and secure. Your installation is now complete. (Use furnished plug to close additional air inlet if you want to completely seal the air box.

Step 18: Re-connect negative battery terminal.

Step 19: (Optional) To seal up auxiliary opening of air box positioned in front of grill, use supplied plug.

**NOTE: Retighten all connections after approximately 100-200 miles.**

Page left blank intentionally



Page left blank intentionally

Page left blank intentionally



Air Filters



P/N: 20-91059

Air Filters



P/N: 21-91059

Blue Squeeze Restore Kit



P/N: 90-50501

aFe Power Backpack



P/N: 40-33203

aFe Power Diesel T-Shirt



P/N: 40-30222-G (L)  
P/N: 40-30223-G (XL)  
P/N: 40-30224-G (2XL)  
P/N: 40-30225-G (3XL)

aFe Power Hat



P/N: 40-10114 (S/M)  
P/N: 40-10115 (L/XL)

aFe Power Ladies Hat



P/N: 40-10112

Blue Aerosol Restore Kit



P/N: 90-50001



**SAVE \$25**  
ON A REPLACEMENT  
**MOMENTUM**  
AIR FILTER. TO RECEIVE YOUR DISCOUNT PLEASE CALL  
**888.901.7693**

To purchase any of the items above, view airflow charts, dyno graphs, photos, and video; please go to [aFepower.com](http://aFepower.com).

# Warranty

## General Terms:

- aFe warrants their products to be free from manufacturer's defects due to workmanship and material.
- This warranty applies only to the original purchaser of the product and is non-transferrable.
- Proof of purchase of the aFe product is required for all warranty claims.
- Warranty is valid provided aFe instructions for installation and/or cleaning were properly followed.
- Proper maintenance with regular inspections of product is required to insure warranty coverage.
- Damage due to improper installation, abuse, unauthorized repair or alteration is not warranted.
- Incidental or consequential damages or cost, including installation and removal of part, incurred due to failure of aFe product is not covered under this warranty.
- All warranty is limited to the repair and/or replacement of the aFe part. To request Return Goods Authorization ("RGA"), email [RGA@afepower.com](mailto:RGA@afepower.com) or call (951)493-7100. Upon receipt of the RGA, you must return the product to the address provided in the RGA, freight prepaid and accompanied with a dated proof of purchase and the RGA. Upon receipt of the defective product and upon verification of proof of purchase, aFe will either repair or replace the defective product within a reasonable time, not to exceed thirty days.

<b>Product Category</b>	<b>P/N Prefix</b>	<b>Warranty duration</b>
Direct OE Replacement Filters	10, 11, 30, 31, 71, 73	Life of the vehicle
Racing Filters	18	1 year
Universal	21, 24, 72	2 years
Air Intake Systems	50, 51, 54, 55, 75	2 years
Exhaust Systems	49	2 years
Intercoolers & Intercooler Tubes	46-2	2 years
Intake Manifolds	46-1	2 years
Differential Cover	46-7	Life of the vehicle
Exhaust Manifolds	46	2 years
Throttle Body Spacers	46-3	2 years
Fluid Filters	44	90 days
Pre-Filters	28	2 years
Heavy Duty OE Replacement	70	2 years
PowerSports OE Replacement	81, 87	2 years
PowerSports Intake Systems	85	2 years

No other warranty expressed or implied applies nor is any person or advanced FLOW engineering authorized to assume any other warranty. Some States do not allow the exclusion or limitation of incidental or consequential damages or do not allow limitations on how long an implied warranty lasts, so the above limitations or exclusions may not apply to you. This warranty gives you specific legal rights, and you may also have other rights which vary from State to State.

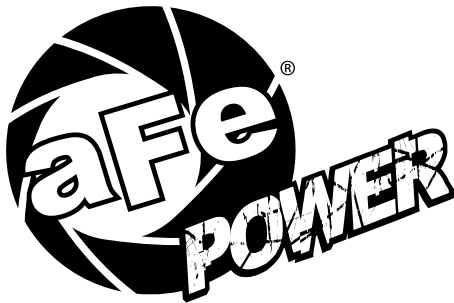

**advanced FLOW engineering, inc.**

252 Granite Street Corona, CA 92879

TEL: 951.493.7155 • TECH: 951.493.7100