

INSTALLATION INSTRUCTIONS AND PARTS LIST

MODEL 570929 W2W MEGA STEP BRACKETS:

2009 AND NEWER FORD F-150 REGULAR CAB PICKUPS
2009 AND NEWER FORD F-150 SUPER CAB PICKUPS
2009 AND NEWER FORD F-150 SUPERCREW PICKUPS



1. READ INSTRUCTIONS COMPLETELY AND CHECK TO MAKE SURE THAT ALL REQUIRED PARTS (LISTED ON SERVICE PARTS LIST) ARE ON HAND BEFORE STARTING THE INSTALLATION.
2. EXISTING MOUNTING HOLE PATTERNS ARE LOCATED ON THE PINCH WELD AND INTERIOR WALL OF THE ROCKER PANEL. THESE MOUNTING HOLE PATTERNS WILL BE USED TO MOUNT THE CAB BRACKETS FOR THIS INSTALLATION PER THE FOLLOWING INSTRUCTIONS.
 - 2.1. INSTALL 5/16" MULTI THREAD U-NUTS (ITEM #5) IN THE TOP REAR HOLES OF THE FRONT AND CENTER PATTERNS AND IN THE TOP FRONT HOLE OF THE REAR PATTERN AS SHOWN. INSTALL THESE U-NUTS SO THAT THE THREADS ARE TO THE INSIDE OF THE ROCKER PANEL. (THIS IS DONE BY INSERTING THE THREADED HALF OF THE U-NUT THRU THE LARGE ACCESS HOLES AND SLIDING THE U-NUT TOWARDS THE ROUND HOLE UNTIL IT SEATS IN THE ROUND HOLE).
3. ATTACH THE FRONT AND REAR MOUNTING BRACKETS (ITEM #2) TO THE VEHICLE.
 - 3.1. POSITION THE BRACKETS ON THE VEHICLE SO THAT THE TOP HOLE LINES UP WITH THE MULTI THREAD U-NUT AND THE HOLE IN THE OFFSET LINES UP WITH THE HOLE IN THE PINCH WELD. ATTACH THE TOP OF THE BRACKET WITH A 5/16" X 1.00" ZINC PLATED HEX HEAD CAP SCREW (ITEM #6) AND 5/16" ZINC PLATED FLAT WASHER (ITEM #7). ATTACH THE BOTTOM OF THE BRACKET TO THE PINCH WELD WITH A 5/16" X 1.00" BLACK PLATED HEX HEAD CAP SCREW (ITEM #8) 5/16" BLACK PLATED FLAT WASHER (ITEM# 9) AND 5/16" SERRATED FLANGE NUT (ITEM # 4). LEVEL THE BRACKETS AND TIGHTEN THE FASTENERS TO 19 LB FT.
 - 3.2. FOR REG CABS & SUPER CABS THE CENTER BRACKET CAN BE INSTALLED THE SAME WAY AS IN STEP 3.1 FOR SUPER CREW PROCEED TO STEP 4.

SUPER CREW ONLY

4. ATTACH THE MIDDLE MOUNTING BRACKET (ITEM #2) TO THE VEHICLE
 - 4.1 ATTACH ANGLE BRACKET (ITEM #10) TO MOUNTING BRACKET (ITEM #2) WITH A 5/16" X 1.00" ZINC PLATED HEX HEAD CAP SCREW (ITEM #6) AND A 5/16" SERRATED FLANGE NUT (ITEM #4) TOGETHER WITH THE ANGLE TOWARDS THE MULTI THREAD U-NUT IN THE HOLE THAT IS OFFSET FROM THE PINCH WELD HOLE. REPEAT STEP 3.1 USING ANGLE BRKT.
5. ATTACH INBOARD BRACKET AND OUTBOARD BRACKET (ITEMS #11&12) USING 5/16" X 1.00" BLACK ZINC PLATED HEX HEAD CAP SCREW (ITEM# 8) AND (4) 5/16" BLACK ZINC PLATED FLAT WASHERS (ITEM# 9) AND SERRATED FLANG NUT BLACK ZINC (ITEM# 14). FINGER TIGHT ONLY UNTIL BOARD IS POSITIONED.
 - 5.1 REMOVE FACTORY NUT FROM SHACKLE MOUNT. PLACE BRACKET OVER STUD AND REPLACE FACTORY NUT. FINGER TIGHTEN ONLY

LUVERNE
ISO9001 QS9000 CERTIFIED TRUCK
EQUIPMENT
INC.
1200 Birch Street
Brandon, SD 57005

6. ATTACH THE STEP (ITEM #1) TO THE MOUNTING BRACKETS.
 - 6.1. INSERT FOUR (4) 5/16" SQUARE HEAD SCREWS (ITEM #3) IN THE CENTER SLOT ON THE UNDER SIDE OF THE STEP.
 - 6.2. POSITION THE STEP ON THE FRONT THREE MOUNTING BRACKETS SO THAT THE SQUARE HEAD SCREWS ARE LOCATED IN THE SLOTS OF THE MOUNTING BRACKETS AND THE STEP IS CENTERED, FRONT TO REAR, ON THE CAB.
 - 6.3. LOCATE THE STEP, IN AND OUT, AS DESIRED AND INSTALL 5/16" SERRATED FLANGE NUTS (ITEM #4) ON THE SQUARE HEAD SCREWS. (JUST START THE FLANGE NUTS ON THE SCREWS).
 - 6.4. ADJUST THE REAR BRACKET, UP AND DOWN, SO THAT THE STEP MOUNTING SURFACE IS FLUSH UP UNDER THE STEP PLATE. LOCATE THE SQUARE HEAD SCREWS IN THE SLOTS OF THE MOUNTING BRACKET, INSTALL 5/16-18 SERRATED FLANGE NUTS AND TIGHTEN ALL 5/16" NUTS TO 19 LB FT.
 - 6.5. INSTALL 5/16" SERRATED FLANGE NUTS (ITEM #4) ON ANY UNUSED SQUARE HEAD SCREWS IN THE INBOARD SLOT OF THE STEP AND TIGHTEN TO 19 LB FT.
 - 6.6. TIGHTEN (ITEMS #11 &12) DRIVERS SIDE. AND (ITEMS #11 & 13) PASSENGER SIDE TO 19 LB FT.

7. TORQUE THE 3/4-10 NUT ON THE REAR MOUNTING BRACKETS TO 40 LB FT.

SERVICE PARTS LIST

ITEM	PART NO.	QTY	DESCRIPTION
1		2	MEGA STEP BOARD ASSEMBLY (SOLD SEPARATELY) LENGTH WILL VARY DEPENDING ON APPLICATION
2	551560	6	BRKT- MTG, STEP, F-150 PICKUP
3	106880	8	SCREW-SQUARE HEAD, 5/16 18 UNC
4	102680	24	NUT-SERRATED FLANGE, HEX, SST, 5/16-18 UNC
5	104264	6	U-NUT- MULTI THREAD, 5/16-18 UNC, STL, BLK
6	100647	8	SCREW- HEX HEAD CAP, 5/16 18 UNC X 1.00".ZP
7	100034	10	WSHR-PL, A, STL, 5/16,.375 ID X .875 OD X .083 THK, ZP
8	106997	10	SCREW- HEX HEAD CAP, 5/16 18 UNC X 1.00", SST, BZP
9	106998	6	WSHR-PL, A, SST, 5/16,.375 ID X .875 OD X .083 THK, BZP
10	551559	2	BRKT-MTG,ANGLE, CENTER, 09 F-150 PICKUP
11	551721	2	BRKT-STEP, REAR,OUTBOARD
12	551726	1	BRKT-STEP, REAR, INBOARD, LH, W2W
13	551727	1	BRKT-STEP, REAR, INBOARD, RH, W2W
14	106996	4	NUT-FLG,HEX,SST,5/16-18 BZP

LUVERNE LOGO SHOULD BE TOWARD REAR OF VEHICLE

1 RIGHT HAND
LEFT HAND

UNUSED SQUARE HEAD SCREW

4 SERRATED FLANGE NUT FOR UNUSED SQUARE HEAD SCREW

3 SQUARE HEAD SCREWS MUST BE INSTALLED IN SLOT FROM END OF STEP

FACTORY NUT

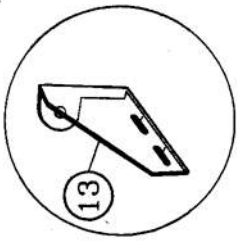
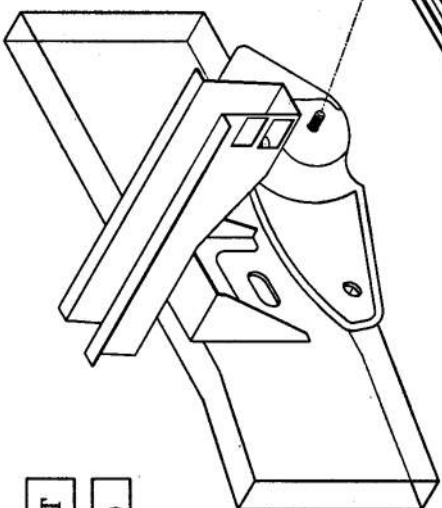

PASSENGER SIDE BRACKET

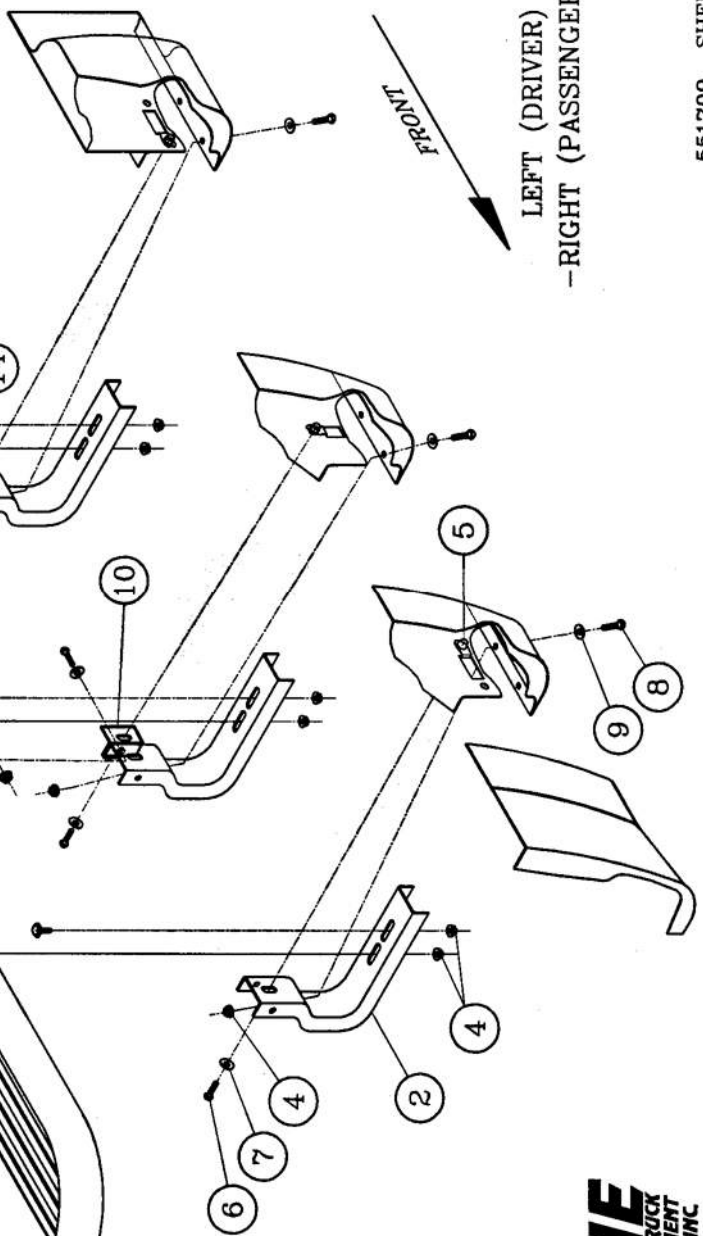

FRONT

LEFT (DRIVER) SIDE SHOWN
--RIGHT (PASSENGER) SIDE OPPOSITE--

SERVICE PARTS LIST

BRACKET NO. - 570929

LUVERNE
TRUCK
EQUIPMENT
INC.
1200 Birch Street
Brandon, SD 57005