

INSTALLATION INSTRUCTIONS AND PARTS LIST

MODEL 570757 MEGA STEPS W2W BRACKETS:

2007+ TOYOTA TUNDRA REGULAR & DOUBLE CAB PICKUPS W/ 6.5' & 8.0 BOXES
07+TOYOTA TUNDRA CREW MAX PICKUP 5.5' BOX



1. READ INSTRUCTIONS COMPLETELY AND CHECK TO MAKE SURE THAT ALL REQUIRED PARTS (LISTED ON SERVICE PARTS LIST) ARE ON HAND BEFORE STARTING THE INSTALLATION.
2. ATTACH THE MOUNTING BRACKETS TO THE VEHICLE USING EXISTING MOUNTING HOLES ON THE INTERIOR WALL OF THE ROCKER PANEL. **(NOTE: THE BRACKETS MUST BE PLACE IN THE PROPER POSITION. THEY ARE IDENTIFIED WITH NOTCHES ON THE INBOARD EDGE. [1 NOTCH IS FOR #1 BRACKET, ETC.] #1 WILL BE AT THE FRONT OF THE VEHICLE. SEE FIG. 1).**
 - 2.1 NOTE THAT ON THE REGULAR CAB APPLICATIONS YOU WILL ONLY USE BRACKETS #1 (ITEM #2) AND #3 (ITEM #4) FOR THE CAB MOUNTS.
 - 2.2 POSITION THE BRACKETS ON THE VEHICLE SO THAT BOTH HOLES LINE UP WITH THE THREADED INSERTS IN THE ROCKER PANEL ATTACH THE TOP OF THE BRACKET WITH A M8-1.25 X 25MM ZINC PLATED HEX HEAD CAP SCREW, 5/16" FLAT WASHER AND LOCK WASHER (ITEMS #6, #7 & #8). LEVEL THE BRACKETS AND TIGHTEN THE FASTENERS TO 19 LB FT.
3. ATTACH THE STEP (ITEM #1) TO THE MOUNTING BRACKETS. **(REAR BRACKET MOUNTS IN STEP 4)**
 - 3.1. INSERT FOUR (4) 5/16" SQUARE HEAD SCREWS (ITEM #10) IN THE CENTER SLOT ON THE UNDER SIDE OF THE STEP. AND ONE (1) INTO OUTER SLOT FOR THE BOX BRACKET.
 - 3.2. POSITION THE STEP ON THE MOUNTING BRACKETS SO THAT THE SQUARE HEAD SCREWS ARE LOCATED IN THE SLOTS OF THE MOUNTING BRACKETS AND THE STEP IS CENTERED, FRONT TO REAR, ON THE CAB.
 - 3.3. LOCATE THE STEP, IN AND OUT, AS DESIRED, INSTALL 5/16" SERRATED FLANGE NUTS (ITEM #9) ON THE SQUARE HEAD SCREWS AND TIGHTEN TO 19 LB FT.
4. ATTACH THE W2W BRACKET TO THE LEAF SPRING MOUNT.
 - 4.1 INSERT CLIPPED BOLT (ITEM # 16) INTO THE INBOARD BRACKET (ITEM #15) AND PLACE A NUT (ITEM #18) ON JUST A FEW THREADS LEAVING IT LOOSE FOR NOW.
 - 4.2 HOLD BRACKET UP TO LEAF SPRING MOUNT AND PLACE CLIPPED BOLT INTO OBOURND HOLE. FINGER TIGHT.
 - 4.3 INSERT TOP SCREW (ITEM #17) FROM BEHIND FRAME RAIL THROUGH LEAF SPRING MOUNT AND INBOARD BRACKET AND PLACE NUT (ITEM #18)ON FINGER TIGHT.
 - 4.4 MOUNT OUTBOARD BRACKET (ITEM #14) TO INBOARD BRACKET (ITEM #15) USING (2) SCREWS, WASHERS AND NUTS (ITEMS # 11, 12 &13). MOUNT STEP BOARD (ITEM #1) TO OUTBOARD BRACKET WITH (2) 5/16" SERRATED FLANGE NUTS (ITEM # 9) ON TO SQUARE HEAD SCREWS AND TIGHTEN ALL FASTENERS TO 19 LB FT.

LUVERNE
ISO9001 QS9000 CERTIFIED TRUCK
EQUIPMENT
1200 Birch Street
Brandon, SD 57005 INC.

SERVICE PARTS LIST

ITEM	PART NO.	QTY	DESCRIPTION
1		2	MEGA STEP BOARD ASSEMBLY (SOLD SEPARATELY) LENGTH WILL VARY DEPENDING ON APPLICATION
2	551362	2	BRKT- MTG, STEP, #1, TOYOTA TUNDRA
3	551363	2	BRKT- MTG, STEP, #2, TOYOTA TUNDRA
4	551364	2	BRKT- MTG, STEP, #3, TOYOTA TUNDRA
5	551365	2	BRKT- MTG, STEP, #4, TOYOTA TUNDRA
6	102549	16	SCREW-M8-1.25X25MM,ZP
7	100030	16	WASHER-LOCK, 5/16" ZP
8	100034	16	WASHER-FLAT, 5/16" ZP
9	102680	20	NUT-SERRATED FLANGE, HEX, SST, 5/16-18 UNC
10	106880	10	SCREW-SQUARE HEAD, 5/16-18 UNC
11	106997	4	SCREW HHC,SST,5/16 X 1.00,BZP
12	106998	4	WASHER STL,.38 X .88 X.083,BZP
13	106996	4	NUT FLANGED,SST,5/16"-18,BZP
14	551721	2	BRKT-STEP,REAR,OUTBOARD,W2W
15	551728	1	BRKT-MTG,INBOARD,REAR,LH (SHOWN)
15	551729	1	BRKT-MTG,INBOARD,REAR,RH
16	104934	2	BOLT-CLIPPED HD,7/16-14 X 1.00,ZP
17	100069	2	SCR-HEX HD,7/16-14 X 1.25,ZP
18	103737	4	NUT-HEX,FLANGED 7/16-14,ZP

LIVERNE
ISO9001 QS9000 CERTIFIED **TRUCK**
 1200 Birch Street **EQUIPMENT**
 Brandon, SD 57005 **INC.**

551717 SHEET 2 OF 3 01APR10

SERVICE PARTS LIST

MODEL NO. - 570757

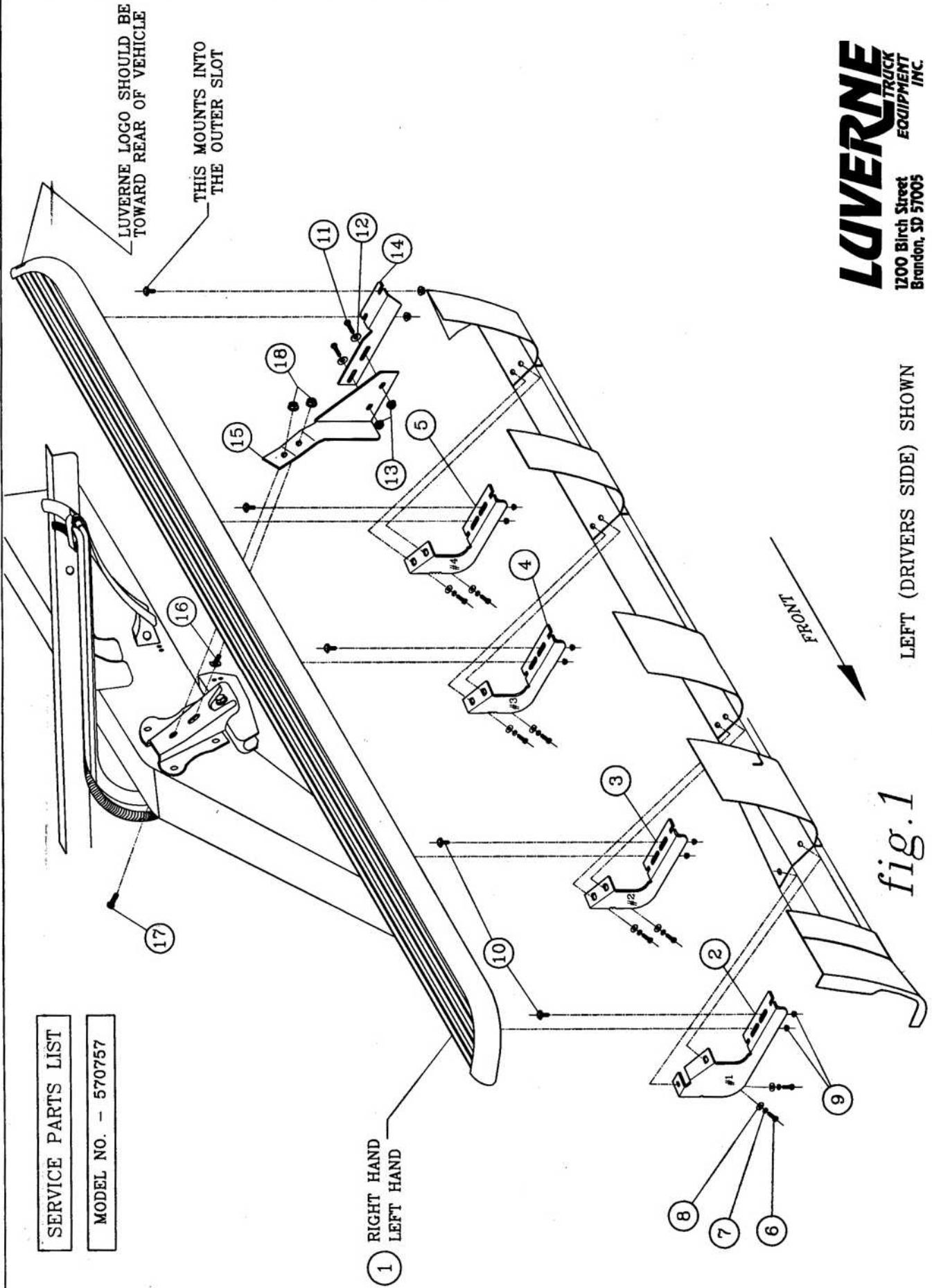

LEFT (DRIVERS SIDE) SHOWN

fig. 1

LUVERNE TRUCK EQUIPMENT INC.
1200 Birch Street
Brandon, SD 57005