

**Installation Instructions**  
**BR20 Rear Bumper Replacement Part # 28371T**  
**2011-2016 Ford F-250 & F-350 Super Duty 2/4WD**  
 Do not attempt to install this product on any vehicle other than the one listed above!

**Parts List**

Item	Qty.	Part #	Description	Item	Qty.	Part #	Description	Torque
1	1		Bumper Replacement Shell	10	4		1/2" x 1 1/2" Hex Bolt	65 Ft. Lbs
2	1		Driver Side Frame Bracket	11	8		1/2" Flat Washer	
3	1		Passenger Side Frame Bracket	12	4		1/2" Lock Washer	
4	2		Flush Mount Light Pod Plate	13	4		1/2" Hex Nut	
5	2		LED License Plate Light	14	10		10-32 x 3/4" Button Head Bolt	
6	1		Bezel Plate (driver outer-V)	15	10		10-32 Nylon-Insert Lock Nut	
7	1		Bezel Plate (driver inner-V V)	16	5		Round Plug	
8	1		Bezel Plate (passenger inner-V V V)	17	1		Rectangular Plug	
9	1		Bezel Plate (passenger outer-V V V V)					

**ILLUSTRATION #1**

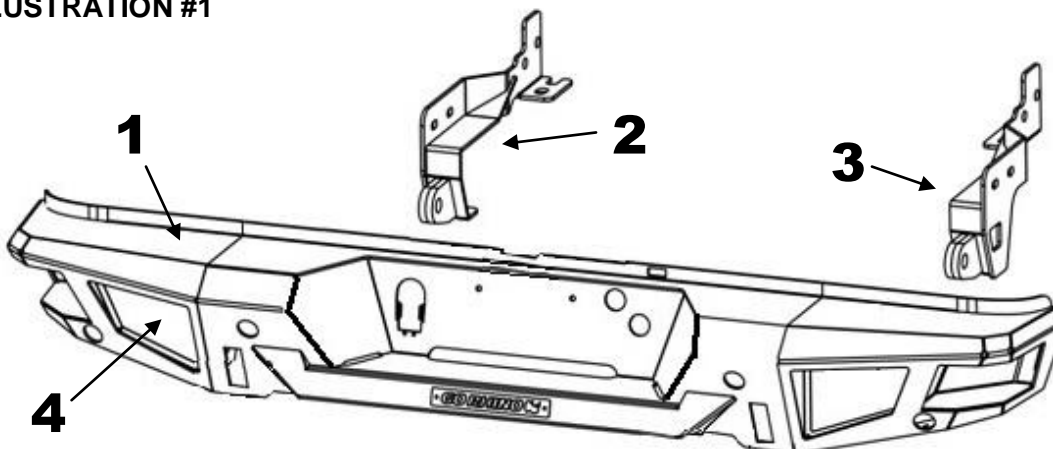

**Tool Required:**

10mm, 21mm, 24mm, 3/8" & 3/4" Sockets  
 3/8" & 3/4" Wrenches  
 Slotted Blade Screw Driver  
 1/8" Hex Key  
 Ratchets, Ratchet Extensions, Swivel Joint Adapters & Breaker Bar  
 12V Circuit Tester

**Approximate installation time: 90 min**

**Read the assembly and installation instructions completely and verify that all of the parts listed are accounted for. If you have defective, missing or damaged parts or need assistance, please contact Go Rhino Products for fast, friendly customer service at: Phone Number / 714-257-7392 / Fax Number / 714-672-0278 / email: [warranty@gorhino.com](mailto:warranty@gorhino.com)**

## Factory Bumper Removal

**Step-1** Disconnect the vehicle battery or batteries.

**Step-2** Disconnect the factory bumper wiring harness for the license plate light and reverse proximity sensor from the vehicle wiring harness, (Photo 1).

**Step-3** Remove the nuts (2) per side and bolt plate securing the factory bumper brackets to the side of the frame using a 21mm socket and ratchet, (Photo 2). Remove the factory bumper from the vehicle and set it aside. Retain the nuts and bolt plates to install the bumper replacement brackets.

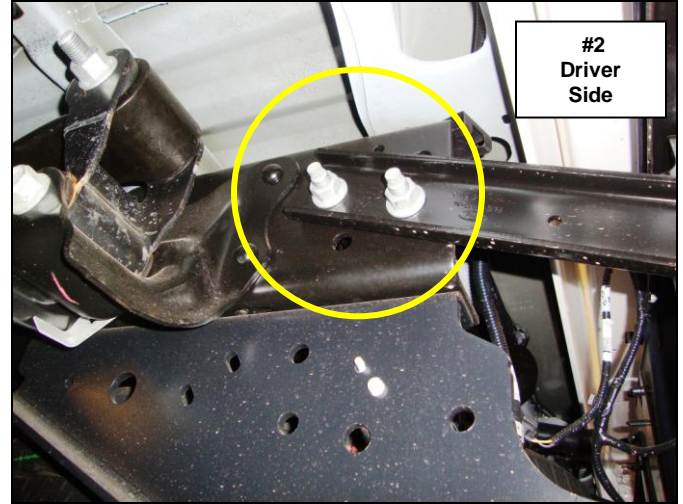
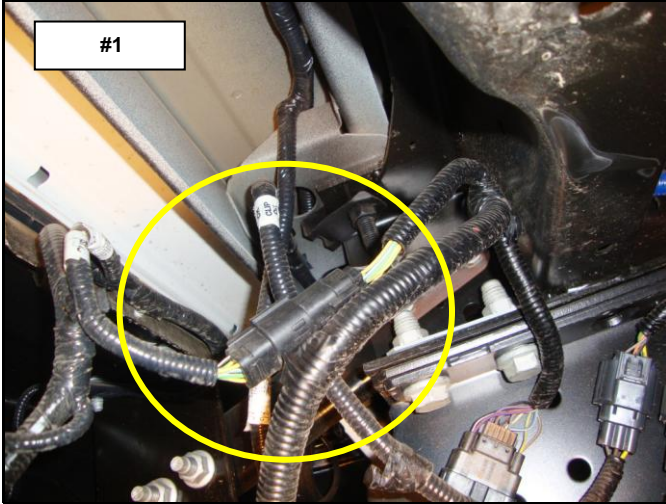

**Step-4** The factory receiver hitch is attached to the bottom of each frame rail with (2) sets of nuts and bolt plates, 2 at the front and (2) at the rear. Remove the nuts and bolt plates at the rear using a 24mm socket and ratchet, (Photo 3). Retain the nuts and bolt plates to install the bumper replacement brackets and reinstall the factory receiver hitch.

**Step-5** Remove the (2) bolts securing the trailer plug bracket to the bottom of the receiver hitch using a 10mm socket and ratchet. Disconnect the wiring harness and remove the trailer plug from the bracket, (Photo 4).

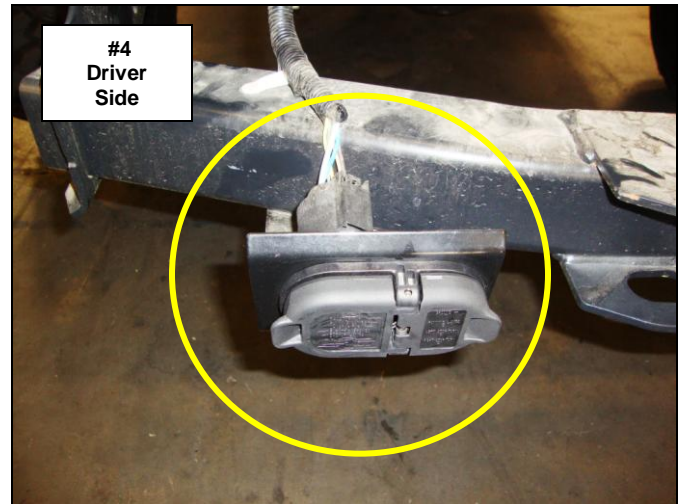
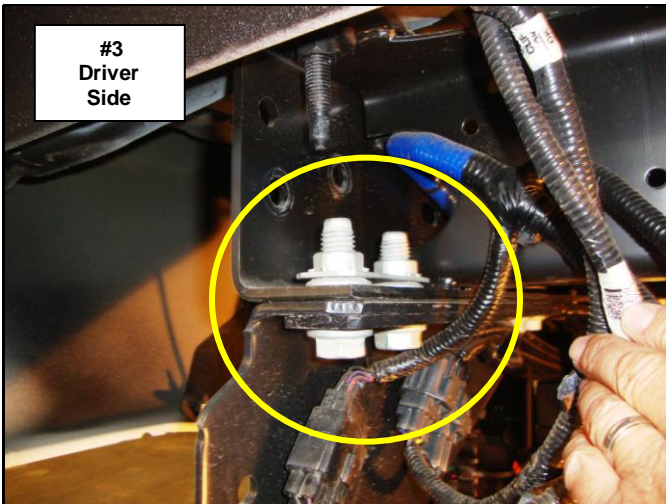

## BR20 Bumper Replacement Installation

**Note:** if your vehicle is not equipped with rear **Park Assist** install the supplied round plugs in the holes in the replacement bumper and proceed to Step 7.

**Note:** If you are replacing a bumper with rear **Park Assist**, the sensor detection zone will be altered with use of this bumper replacement.

**Step-1** If the vehicle is equipped with rear Park Assist, disconnect the sensors from the factory bumper wiring harness and remove the wiring harness from the bumper.

**Step-2** Remove each sensor from the plastic bezel by gently spreading the bezel tabs and pulling out on the back of the sensor. Note: Do not push on the front of the sensor as this may damage the sensor.

**Step 3** Remove the sensor bezels from the factory bumper by depressing the tabs around the base and pushing the bezel out through the front of the bumper. Note: The sensors and bezels have to be positioned in the replacement bumper in the same location (inner and outer), (driver and passenger) as removed from the factory bumper.

**Step-4** Install the sensor bezels and sensors in the matching bezel plates, (Photo 1 & 2). Line up the protrusions on the bezel with the profile in the bezel plate; push the bezel through the profile in the plate until the tabs around the base lock in position, then install the sensor in the bezel. Note: The **U** notches in the bezel plate designate the top and the **V** notch or notches on the side designate the position in the replacement bumper.

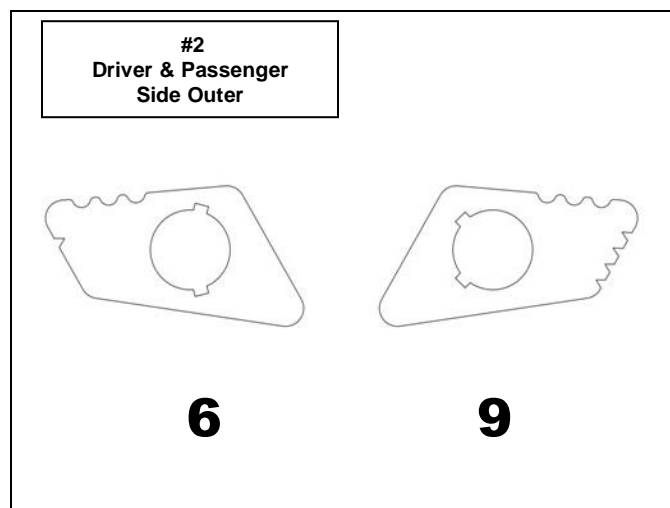
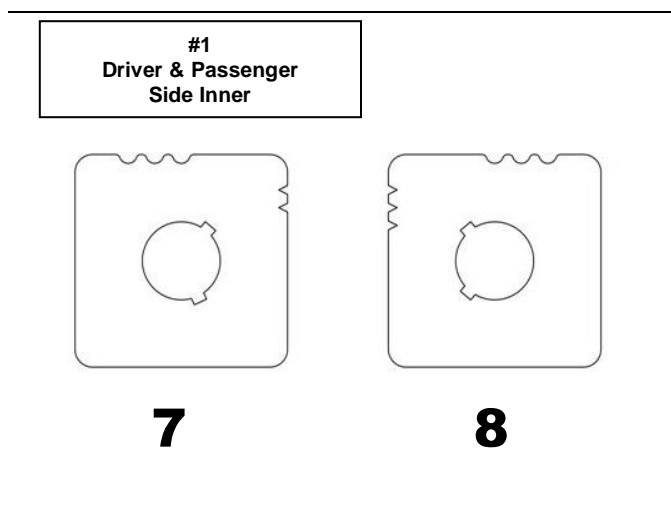

**Step-4** Prepare the inside surface of the bumper shell where the bezel plates will be mounted with Isopropyl alcohol. A clean, dry surface is required in order for tape to stick properly.

**Step-5** Peel the backing off from the double sided tape to uncover the adhesive. From inside the bumper shell position each bezel, sensor and bezel plate assembly, making sure the sensor bezel is centered in the hole provided in the bumper shell, (Photo 3 & 4).

**Step-6** Stick the assembly in place and apply firm pressure for about 30 seconds. The tape needs to bond with the mounting surface, and it needs pressure to do this. The bezel mounting plate will seem like it is stuck on, but continue pressing for at least 30 seconds. Note: At room temperature approximately 50% of ultimate bond strength will be achieved after 20 minutes, 90% after 24 hours and 100% after 72 hours.

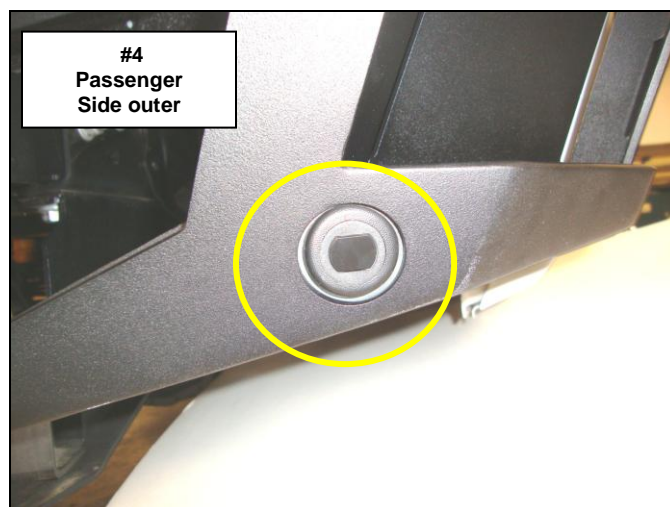
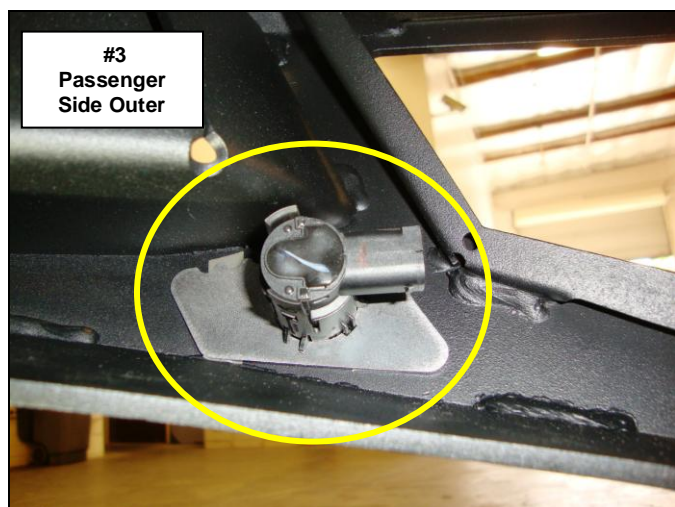

**Step-7** Position the driver side frame bracket inside the frame rail and secure the bracket to the side of the frame using the nuts and bolt plate used to attach the factory bumper bracket to the frame, (Photo 5). Snug but do not fully tighten the nuts and paired bolts at this time.

**Step-8** Secure the frame bracket lower flange and factory receiver hitch to the frame using the nuts and bolt plate used to attach the factory bumper bracket to the frame, (Photo 6).

Snug but do not fully tighten the nuts and paired bolts at this time. Repeat step 7 and 8 to install the passenger side frame bracket.

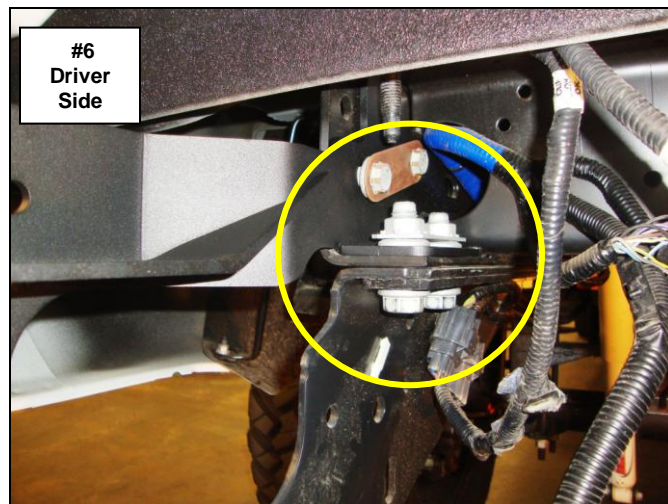
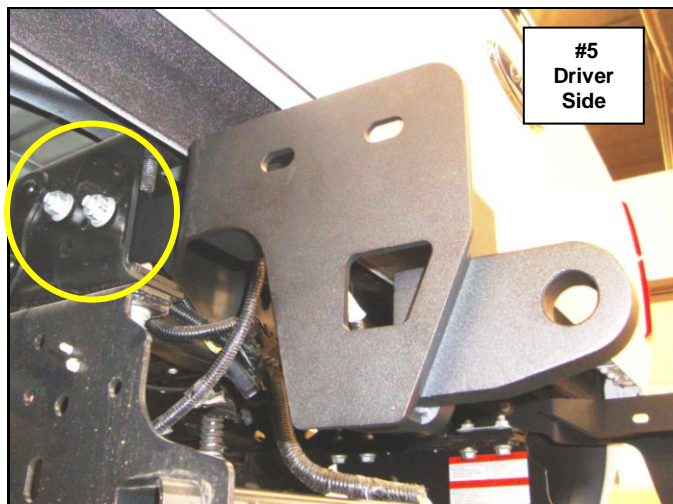

**Step-9** With assistance attach the bumper shell brackets to each frame bracket using (2)  $\frac{1}{2}$ " x  $1\frac{1}{2}$ " hex bolts, (4)  $\frac{1}{2}$ " flat washers, (2)  $\frac{1}{2}$ " lock washers and (2)  $\frac{1}{2}$ " Hex nuts, (Photo 7). Align the bumper shell with the vehicle, verify that the tailgate clears when lowered, then tighten the nuts and bolt plate securing the frame bracket to the side of the frame first then tighten all remaining factory and supplied nuts and bolts.

If necessary for alignment loosen the nuts and bolt plate securing the frame brackets to the frame (one side at a time), adjust the bumper shell alignment then tighten the nuts and bolt plate securing the bracket to the side of the frame first then all remaining factory and supplied nuts and bolts, (Photo 8).

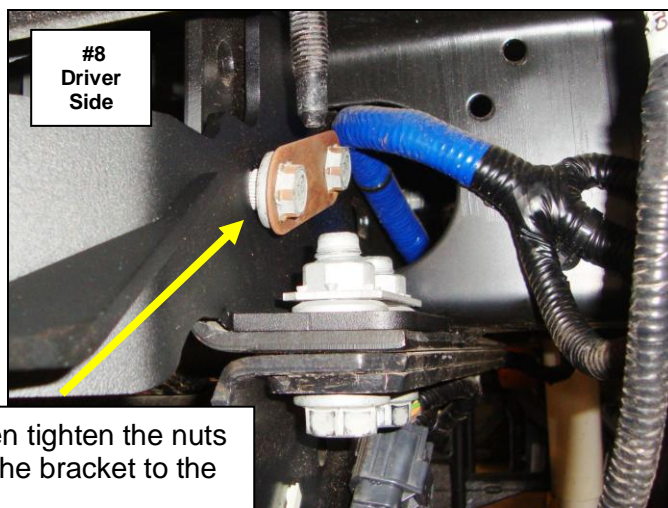
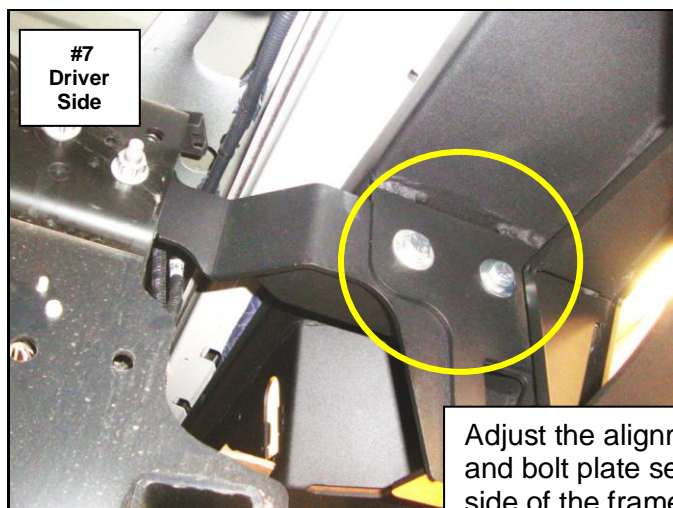

Adjust the alignment then tighten the nuts and bolt plate securing the bracket to the side of the frame first.

**Step-10** Remove the trailer plug from the factory bumper and install it in the bumper shell, and reconnect the wiring harness, (Photo 9 & 10).

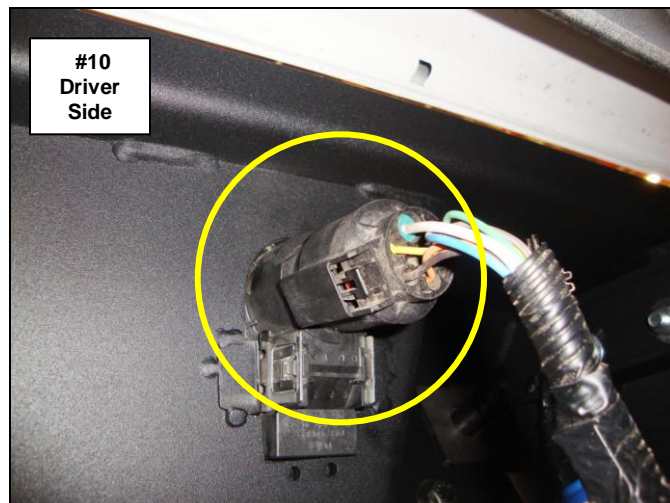

**Step-11** Reconnect the factory bumper wiring harness to the sensors and to the vehicle wiring harness.

**Step-12** Install the license plate using the supplied LED lights and fasteners to the bumper shell. Use a circuit tester to find the hot and ground from the factory license plate light wiring, and then splice the wires from the supplied lights.

**Step-13** Install the supplied rectangular and round plugs to fill the unused spare tire winch access holes in the bumper shell.

**Step-14** Install the supplied flush mount light pods plates or optional light mounts to the bumper shell using (4) 10-32 x 3/4" button head bolts and (4) 10-32 lock nuts.

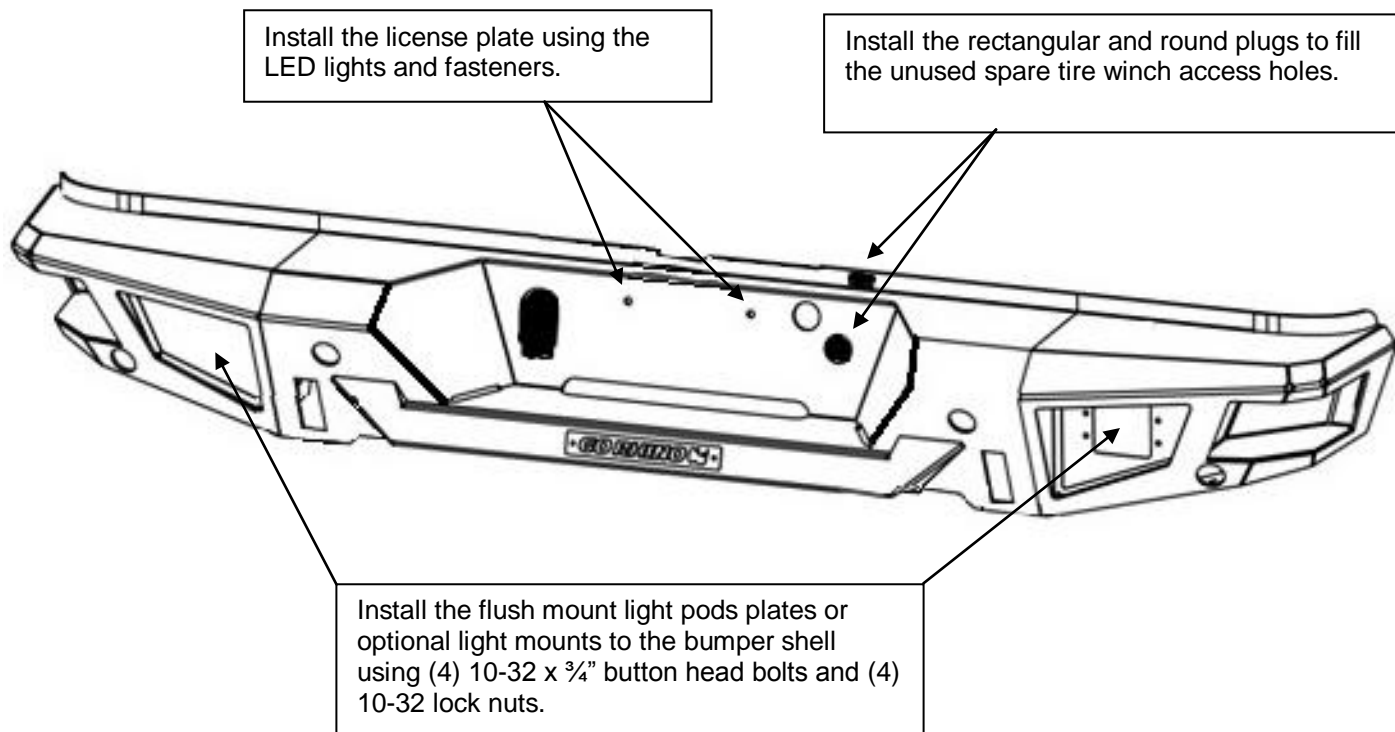

**Step-15** Remember to check and retighten all factory and supplied nuts and bolts periodically.