

12291

2004 - CURRENT CHEVY EQUINOX / GMC TERRAIN / 2004 - 2007 SATURN VUE
REDLINE 2001 - 2007 SATURN VUE / 2006- 2009 PONTIAC TORRENT

5/11/2016

GROSS LOAD CAPACITY WHEN USED AS A WEIGHT CARRYING HITCH: 3500 LBS. TRAILER WEIGHT & 350 LBS. TONGUE WEIGHT.

DO NOT EXCEED VEHICLE MANUFACTURER'S RECOMMENDED TOWING CAPACITY.

WARNING: ALL NON-TRAILER LOADS APPLIED TO THIS PRODUCT MUST BE SUPPORTED BY AUXILIARY STABILIZING STRAPS.

** FAILURE TO PROPERLY SUPPORT NON-TRAILER LOADS WILL VOID PRODUCT WARRANTY**

HAVING INSTALLATION QUESTIONS? CALL TECHNICAL SUPPORT AT 1-800-798-0813

Parts List			
ITEM	QTY	PART NUMBER	DESCRIPTION
1	1	CM-500-FW	FISHWIRE TOOL
2	6	M12-1.75 x 40mm	HEX BOLT
3	6	1/2"	CONICAL TOOTHED WASHER
4	2	1/2-13 x 1 3/4	CARRIAGE BOLT
5	2	CM-SP1	.250 x 1.50 x 2.00" SQUARE HOLE SPACER
6	2	HFN 1213	HEX FLANGE NUT

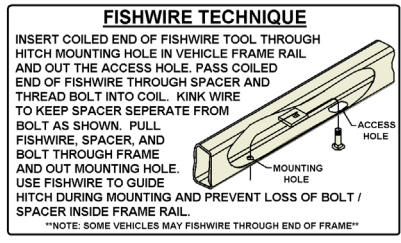
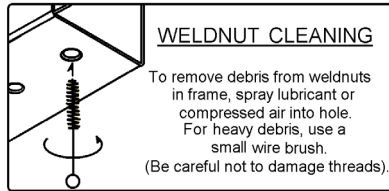

TOOLS REQUIRED	
RATCHET	
TORQUE WRENCH	
8" EXTENSION	
19mm SOCKET	
3/4" SOCKET	
NEEDLENOSE PLIERS	

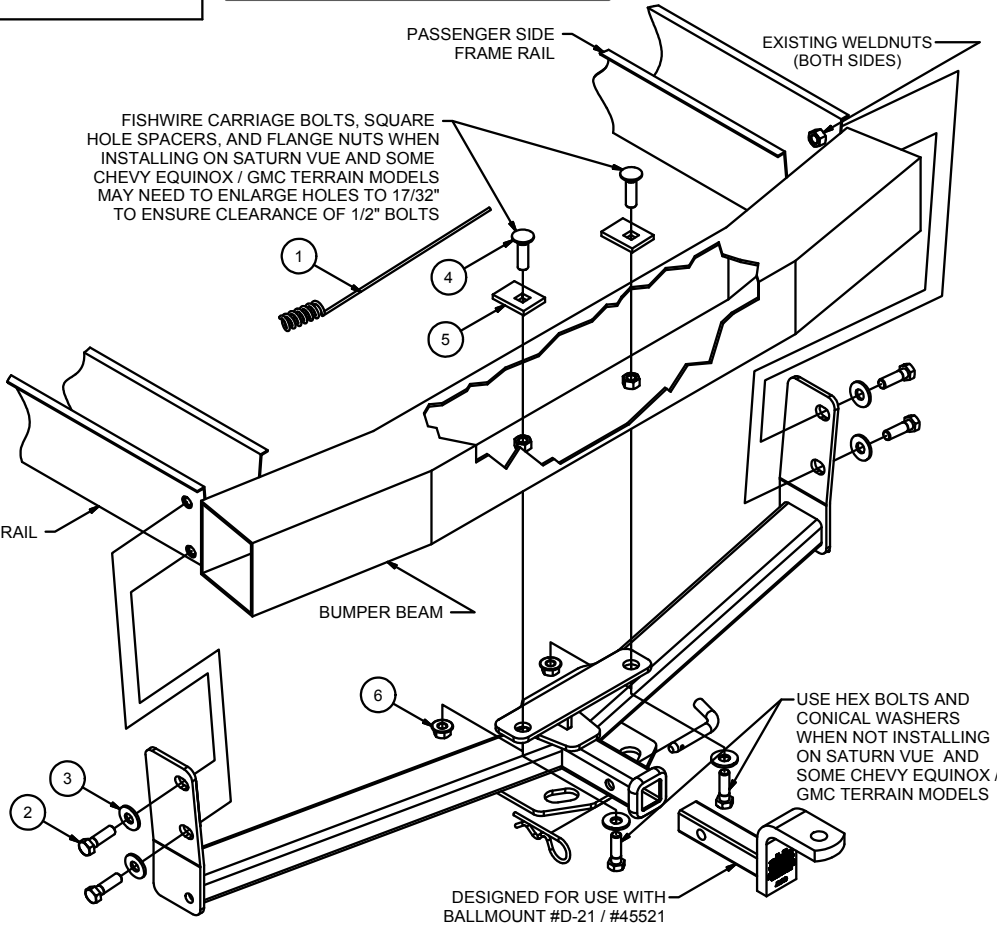

HITCH WEIGHT: 33 LBS.
 INSTALL TIME
 PROFESSIONAL: 30 MINUTES
 NOVICE (DIY): 65 MINUTES
 INSTALL NOTES:
 - NO DRILLING REQUIRED

NOTE: Fascia trimming required on Saturn Vue Redline

- ### INSTALLATION STEPS
1. On the Chevy Equinox and GMC Terrain, it is necessary to remove the panel at the center of the fascia to provide space for hitch installation. (Return the panel to vehicle owner.)
 2. Remove existing M12 fasteners from outside surfaces of frame rails, If present remove tie down brackets and return to customer.
 3. Raise hitch into position and fasten to bumper beam using M12 bolts and conical washers.
 4. Install M12 bolts and conical washers on outside surfaces of frame rails. (NOTE: If weldnuts contain debris; 1. Spray with penetrating oil, let soak for 5 mins. 2. Clean weldnut with wire brush and compressed air. 3. If necessary, use a M12-1.75 tap to clean weldnut.)
 5. Fishwire remaining carriage bolts and square hole spacers through end of bumper beam. (See FISHWIRE TECHNIQUE.) (NOTE: May need to enlarge holes to 17/32" to ensure clearance of 1/2" bolts)
 6. Torque all M12 hardware to 79 ft-lbs and torque all 1/2" hardware to 110 ft-lbs.
- PERIODICALLY CHECK THIS RECEIVER HITCH TO ENSURE THAT ALL FASTENERS ARE TIGHT AND THAT ALL STRUCTURAL COMPONENTS ARE SOUND.**

Curt Manufacturing Inc., warrants this product to be free of defects in material and/or workmanship at the time of retail purchase by the original purchaser. If the product is found to be defective, Curt Manufacturing Inc., may repair or replace the product, at their option, when the product is returned, prepaid, with proof of purchase. Alteration to, misuse of, or improper installation of this product voids the warranty. Curt Manufacturing Inc.'s liability is limited to repair or replacement of products found to be defective, and specifically excludes liability for incidental or consequential loss or damage.