

15317**1988-2000 CHEVROLET / GMC FULL SIZE PICKUPS
WITH 10" STEP BUMPER**

12/14/2012

GROSS LOAD CAPACITY WHEN USED AS A WEIGHT CARRYING HITCH: 16,000 LBS. TRAILER WEIGHT & 2,400 LBS. TONGUE WEIGHT.
GROSS LOAD CAPACITY WHEN USED AS A WEIGHT DISTRIBUTION HITCH: 17,000 LBS. TRAILER WEIGHT & 2,400 LBS. TONGUE WEIGHT

***** DO NOT EXCEED VEHICLE MANUFACTURER'S RECOMMENDED TOWING CAPACITY. *****

HAVING INSTALLATION QUESTIONS? CALL TECHNICAL SUPPORT AT 1-800-798-0813

Parts List			
ITEM	QTY	PART NUMBER	DESCRIPTION
1	2	1/2	CONICAL TOOTHED WASHER
2	8	1/2-13 x 1 1/2, GR8	CARRIAGE BOLT
3	4	1/2-13 x 1 3/4	CARRIAGE BOLT
4	2	CM-SP1	.250 x 1.50 x 2.00" SQUARE HOLE SPACER
5	2	CM-SP4	.250 x 1.50 x 3.00" SQUARE HOLE SPACER
6	12	HFN 1213, GR8	HEX FLANGE NUT
7	2	M12 - 1.75 x 50mm	HEX BOLT

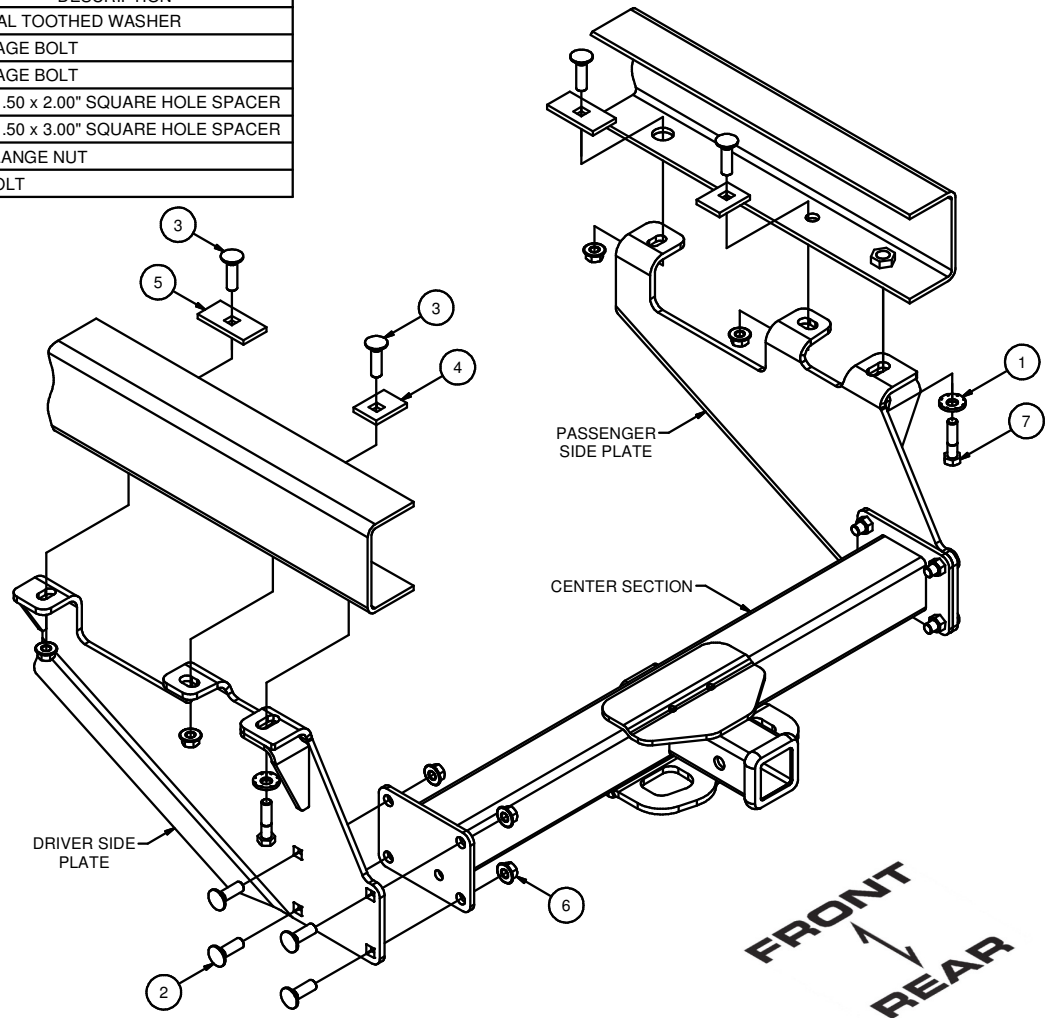
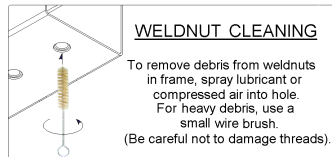
**TOOLS REQUIRED**

RATCHET
3/4" SOCKET
19mm SOCKET
TORQUE WRENCH
SAFETY GLASSES

HITCH WEIGHT: 69 LBS.

INSTALL TIME

PROFESSIONAL: 30 MINUTES
NOVICE (DIY): 60 MINUTES

INSTALL NOTES:

- NO DRILLING REQUIRED
- LOWER SPARE TIRE
- REMOVE FACTORY BOLTS

INSTALLATION STEPS

1. Loosely secure the center section to the driver and passenger side plates with 1/2" x 1-1/2 carriage bolts and hex flange nuts as shown.
2. Lower spare tire for ease of installation.
3. Remove existing bumper bracket bolts from both frame rails. Return hardware to vehicle owner.
4. Align rearmost holes in side plates with the bolt holes from Step 3.
5. Secure hitch with supplied M12 hex bolts and conical toothed washers into rearmost hole. Install 1/2" x 1-3/4 carriage bolts and SP1 spacers into middle holes and secure with 1/2" flange nuts. Install 1/2" x 1-3/4 carriage bolts and SP4 spacers into forwardmost holes and secure with 1/2" flange nuts.
6. Torque all 1/2" fasteners to 110 ft-lbs.
Torque all 12mm fasteners to 87 ft-lbs.
7. Reinstall spare tire.

PERIODICALLY CHECK THIS RECEIVER HITCH TO ENSURE THAT ALL FASTENERS ARE TIGHT AND THAT ALL STRUCTURAL COMPONENTS ARE SOUND.

Curt Manufacturing LLC., warrants this product to be free of defects in material and/or workmanship at the time of retail purchase by the original purchaser. If the product is found to be defective, Curt Manufacturing LLC., may repair or replace the product, at their option, when the product is returned, prepaid, with proof of purchase. Alteration to, misuse of, or improper installation of this product voids the warranty. Curt Manufacturing LLC.'s liability is limited to repair or replacement of products found to be defective, and specifically excludes liability for incidental or consequential loss or damage.