

13932**1999-2007 CHEVY/GMC TRUCK WITH ROLL PAN**

10/1/2012

GROSS LOAD CAPACITY WHEN USED AS A WEIGHT CARRYING HITCH: 5,000 LBS. TRAILER WEIGHT & 500 LBS. TONGUE WEIGHT.
 GROSS LOAD CAPACITY WHEN USED AS A WEIGHT DISTRIBUTION HITCH: 8,000 LBS. TRAILER WEIGHT & 800 LBS. TONGUE WEIGHT

*****DO NOT EXCEED VEHICLE MANUFACTURER'S RECOMMENDED TOWING CAPACITY.*****

Parts List			
ITEM	QTY	PART NUMBER	DESCRIPTION
1	6	1/2-13 x 1 3/4	CARRIAGE BOLT
2	6	CM-SP12	.250 x 1.00 x 2.00" SQUARE HOLE SPACER
3	6	HFN 1213	HEX FLANGE NUT
4	1	1_4 - 20	NYLOCK HEX NUT
5	1	1_4 - 20 x 3_4 CARRIAGE	CARRIAGE BOLT

TOOLS REQUIRED
RATCHET
EXTENSION
7/16, 3/4 AND 21mm SOCKETS
TORQUE WRENCH

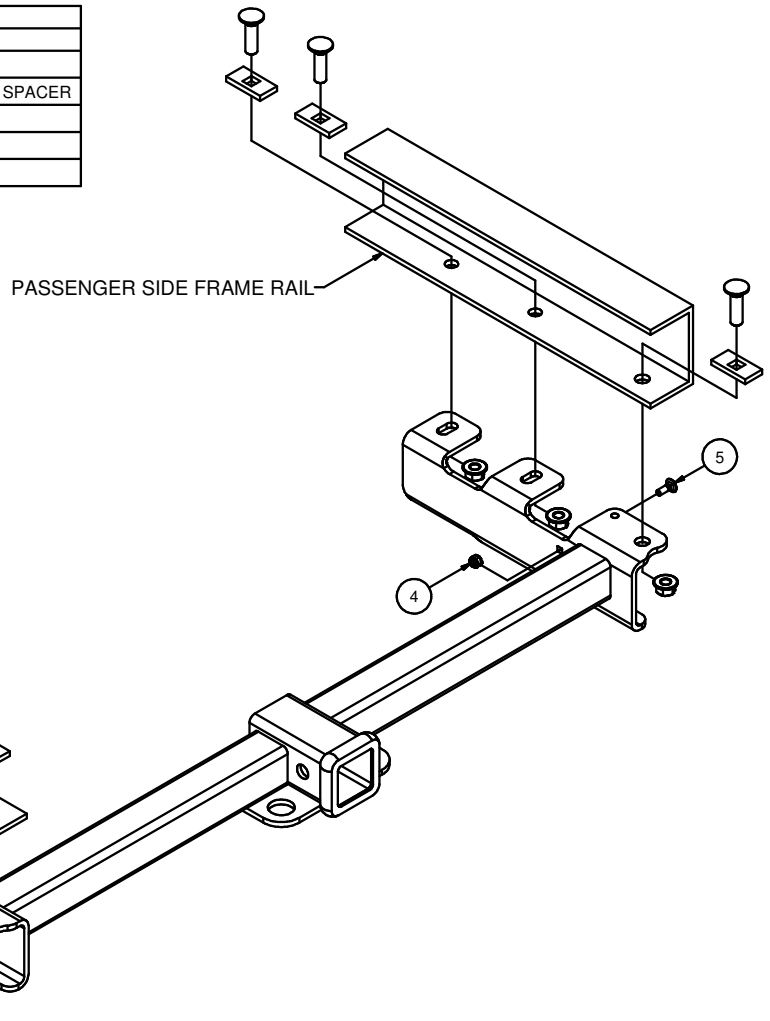

HITCH WEIGHT: 31 LBS.
 INSTALL TIME: 20 MINUTES
 INSTALL NOTES:
 - ROLL PAN MODIFICATION REQUIRED
 - NO DRILLING

Installation Notes:

1. The roll pan requires cutting for this hitch to be installed. Obtain vehicle owner approval before beginning install.
2. Prior to installation, loosen spare tire and remove the ground wire that is bolted to the bottom of the driver side frame. (Not all models will have the ground wire located here.) After installation, relocate the ground wire to the .281" square hole in the frame bracket using the 1/4-20 carriage bolt and the nylon lock nut provided.

Installation Steps:

1. Loosely fasten the hitch to the frame as shown.
2. Torque all 1/2-13 fasteners to 110 lb. ft.; Torque all 1/4-20 fasteners to 12 lb. ft.
3. For drawbar installation cut the roll pan in the license plate area to provide access.

Note: The license plate must be repositioned when the draw bar is installed.

PERIODICALLY CHECK THIS RECEIVER HITCH TO ENSURE THAT ALL FASTENERS ARE TIGHT AND THAT ALL STRUCTURAL COMPONENTS ARE SOUND.

Curt Manufacturing Inc., warrants this product to be free of defects in material and/or workmanship at the time of retail purchase by the original purchaser. If the product is found to be defective, Curt Manufacturing Inc., may repair or replace the product, at their option, when the product is returned, prepaid, with proof of purchase. Alteration to, misuse of, or improper installation of this product voids the warranty. Curt Manufacturing Inc.'s liability is limited to repair or replacement of products found to be defective, and specifically excludes liability for incidental or consequential loss or damage.