

13469

01-05 PONTIAC AZTEC / 02-07 BUICK RENDEZVOUS

7/13/2012

GROSS LOAD CAPACITY WHEN USED AS A WEIGHT CARRYING HITCH: 3,500 LBS. TRAILER WEIGHT & 350 LBS. TONGUE WEIGHT.
 DO NOT EXCEED VEHICLE MANUFACTURER'S RECOMMENDED TOWING CAPACITY.

Parts List			
ITEM	QTY	PART NUMBER	DESCRIPTION
1	1	1/2"	FISHWIRE TOOL
2	2	HFN3816	HEX FLANGE NUT
3	4	HFN 1213	HEX FLANGE NUT
4	4	1/2-13 x 1 3/4	CARRIAGE BOLT
5	4	CM-SP4	.250 x 1.50 x 3.00" SQUARE HOLE SPACER
6	2	3/8"	WASHER
7	2	3_8 - 16 x 1	HEX BOLT

FRONT
 ↕
 REAR

REVERSE PULL FISHWIRE TECHNIQUE

TO FISHWIRE REARWARD HOLE. ATTACH FISHWIRE TO CARRIAGE BOLT AND SLIDE SPACER ONTO FISHWIRE. THEN PUSH THE BOLT THRU THE HOLE FOLLOWED BY THE SPACER (AS SHOWN). PULL BOLT BACK INTO POSITION, PROTRUDING FROM THE FRAME.

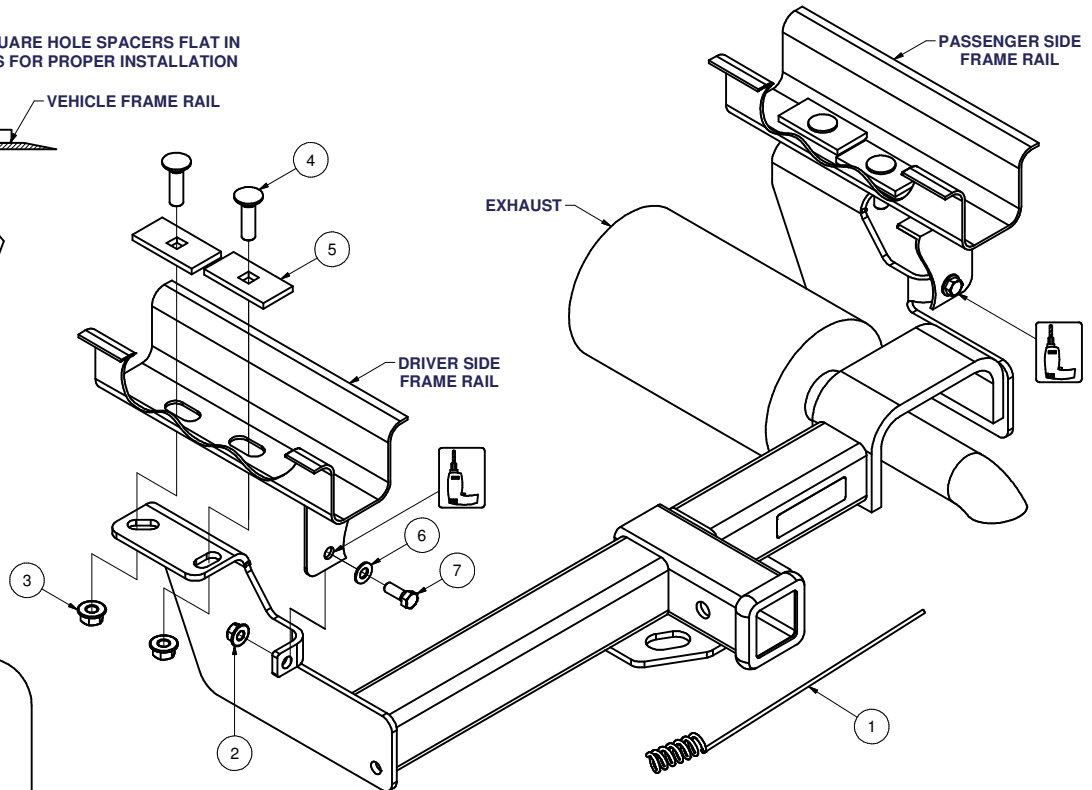
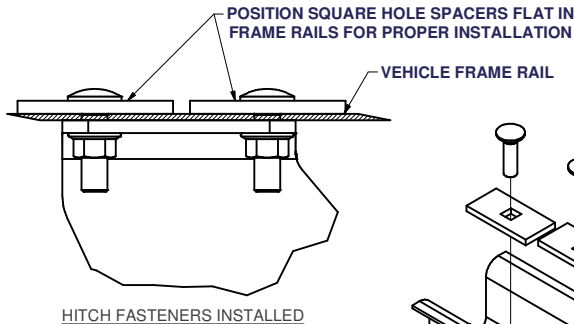
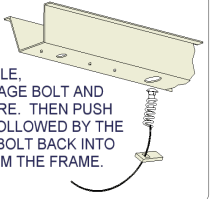

HITCH WEIGHT: 32 LBS.

INSTALL TIME: 30 MINUTES

INSTALL NOTES:

- DRILLING REQUIRED
- LOWER EXHAUST / SPARE TIRE FOR EASE OF INSTALLATION

INSTALLATION STEPS

1. Remove tow hooks if present. If tow hooks are not present remove all existing hardware from the hitch mounting location.
2. For ease of installation you may choose to lower the exhaust and spare tire.
3. Use the slots in the frame to reverse fishwire 1/2" carriage bolts and spacers as shown. (Enlarge access hole as needed) ***NOTE: To properly torque fasteners, spacers must be flat against the bottom of the frame rails as shown.***
4. Raise the hitch into position and secure with 1/2" flange nuts as shown.
5. With hitch in position. Use a 7/16" drill bit and drill holes for 3/8" bolts.
6. Torque 1/2" fasteners to 110 ft-lb and torque 3/8" fasteners to 45 ft-lb.
7. Re-install exhaust and spare tire removed in step 2.

PERIODICALLY CHECK THIS RECEIVER HITCH TO ENSURE THAT ALL FASTENERS ARE TIGHT AND THAT ALL STRUCTURAL COMPONENTS ARE SOUND.

Curt Manufacturing Inc., warrants this product to be free of defects in material and/or workmanship at the time of retail purchase by the original purchaser. If the product is found to be defective, Curt Manufacturing Inc., may repair or replace the product, at their option, when the product is returned, prepaid, with proof of purchase. Alteration to, misuse of, or improper installation of this product voids the warranty. Curt Manufacturing Inc.'s liability is limited to repair or replacement of products found to be defective, and specifically excludes liability for incidental or consequential loss or damage.