

13361 / RRH13361

2002-CURRENT DODGE RAM PICK-UP

4/8/2013

GROSS LOAD CAPACITY WHEN USED AS A WEIGHT CARRYING HITCH: 6,000 LBS. TRAILER WEIGHT & 600 LBS. TONGUE WEIGHT.
 GROSS LOAD CAPACITY WHEN USED AS A WEIGHT DISTRIBUTION HITCH: 10,000 LBS. TRAILER WEIGHT & 1,000 LBS. TONGUE WEIGHT

DO NOT EXCEED VEHICLE MANUFACTURER'S RECOMMENDED TOWING CAPACITY.

Parts List			
ITEM	QTY	PART NUMBER	DESCRIPTION
1	4	1/2 - 13 x 2"	CARRIAGE BOLT
2	2	CM-SP4	.250 x 1.50 x 3.00" SQUARE HOLE SPACER
3	2	CM-SP48	.250 x 2.13 x 2.13" SQUARE HOLE SPACER
4	2	1/2-13 x 2 1/4	HEX BOLT
5	4	CM-SP34	.188 x 1.50 x 3.00" ROUND HOLE SPACER
6	1	1/2"	FISHWIRE TOOL
7	2	CM-SP32	.188 x 1.50 x 2.00" ROUND HOLE SPACER
8	6	HFN 1213	HEX FLANGE NUT
9	2	FW12	FW, 12, ZP

TOW LOOP ATTACHMENT

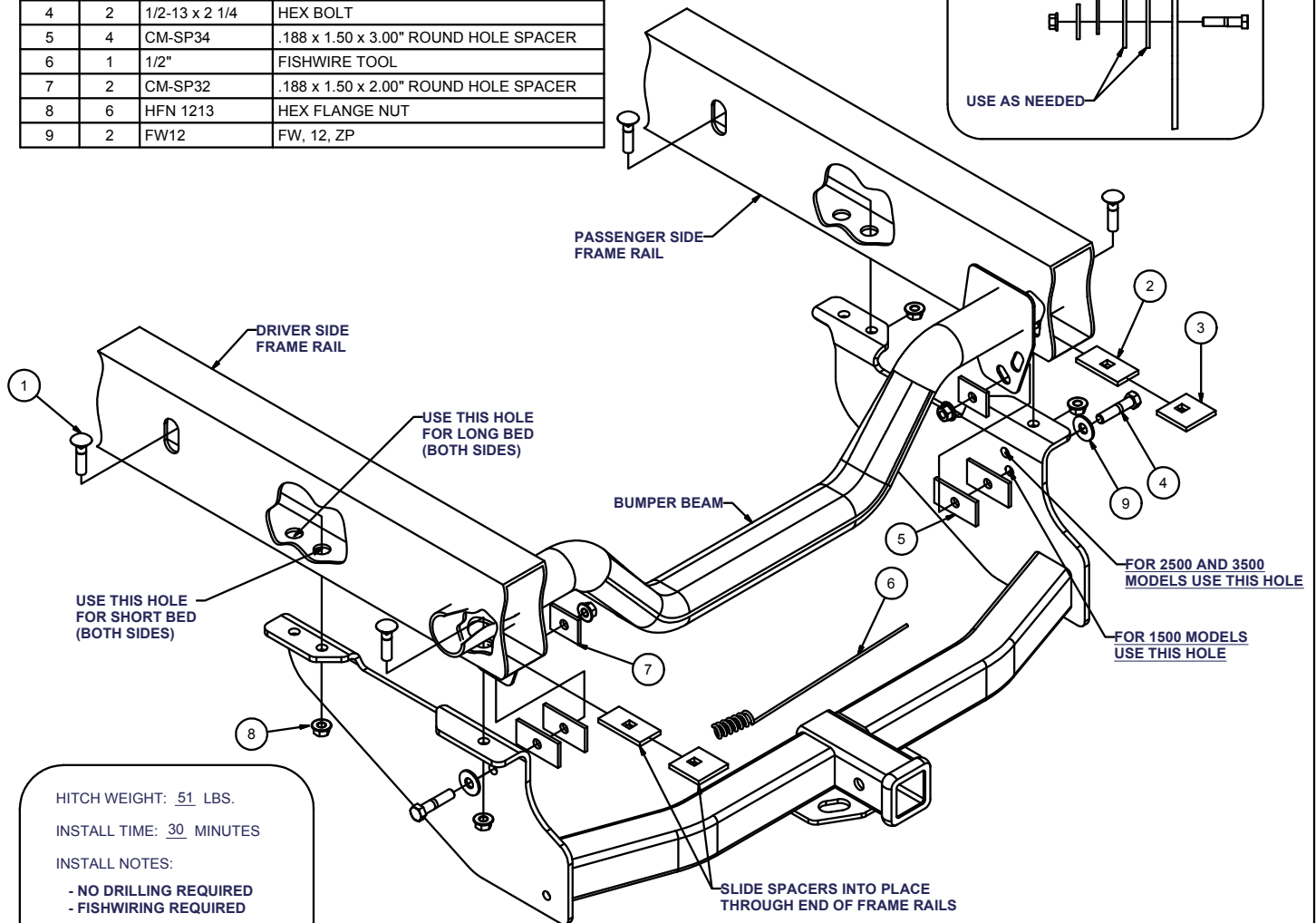
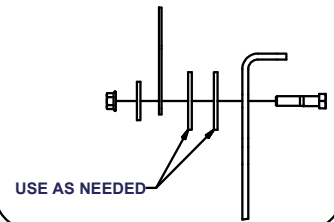

HITCH WEIGHT: 51 LBS.

INSTALL TIME: 30 MINUTES

INSTALL NOTES:

- NO DRILLING REQUIRED
- FISHWIRING REQUIRED

INSTALLATION STEPS

- 1) Raise hitch into position, aligning holes in the hitch to holes in the frame. (See diagram above for short vs long box models).
- 2) Insert hex bolts through side plates and into tow loops. Use spacers as needed between hitch and tow loop. Install outer spacer and flange nut as shown for both sides.
- 3) Using a wire or equivalent, slide the square hole spacers into place as shown. Fishwire forward most carriage bolts into position through access slots in frame. Insert rearward most carriage bolts through bumper beam and through hole, into position as shown for each side.
- 4) Install remaining hex flange nuts and torque all 1/2" fasteners to 110 lb-ft.

PERIODICALLY CHECK THIS RECEIVER HITCH TO ENSURE THAT ALL FASTENERS ARE TIGHT AND THAT ALL STRUCTURAL COMPONENTS ARE SOUND.

Curt Manufacturing Inc., warrants this product to be free of defects in material and/or workmanship at the time of retail purchase by the original purchaser. If the product is found to be defective, Curt Manufacturing Inc., may repair or replace the product, at their option, when the product is returned, prepaid, with proof of purchase. Alteration to, misuse of, or improper installation of this product voids the warranty. Curt Manufacturing Inc.'s liability is limited to repair or replacement of products found to be defective, and specifically excludes liability for incidental or consequential loss or damage.

4/8/2013