

13344

97-07 CHEVROLET VENTURE, 97-05 OLDSMOBILE SILHOUETTE, 97-05 PONTIAC TRANS SPORT,
05-07 MONTANA SV6, 08-CURRENT MONTANA SV6 (CANADA ONLY), 05-08 CHEVROLET UPLANDER,
05-07 SATURN RELAY, 05-07 BUICK TERAZZA

7/13/2012

GROSS LOAD CAPACITY WHEN USED AS A WEIGHT CARRYING HITCH: 4000 LBS. TRAILER WEIGHT & 400 LBS. TONGUE WEIGHT.
GROSS LOAD CAPACITY WHEN USED AS A WEIGHT DISTRIBUTION HITCH: 6000 LBS. TRAILER WEIGHT & 600 LBS. TONGUE WEIGHT

DO NOT EXCEED VEHICLE MANUFACTURER'S RECOMMENDED TOWING CAPACITY.

Parts List			
ITEM	QTY	PART NUMBER	DESCRIPTION
1	2	1/2-13	HANDLE NUT
2	2	1/2 - 13 x 1 1/2	HEX BOLT
3	2	1/2"	CONICAL TOOTHED WASHER
4	1	HFN 1213	HEX FLANGE NUT
5	4	M10 - 1.5 x 45mm	HEX BOLT
6	4	3/8"	CONICAL TOOTHED WASHER
7	1	1/2 - 13 x 2"	CARRIAGE BOLT
8	1	CM-SP1	.250 x 1.50 x 2.00" SQUARE HOLE SPACER
9	1	CM-SP31	.250 x 1.75 x 2.00" U-SHAPE SPACER
10	4	CM-SP42	.250 x 2.00 x 2.00" ROUND HOLE SPACER
11	2	CM-SP32	.188 x 1.50 x 2.00" ROUND HOLE SPACER
12	1	CM-500-FW	FISHWIRE TOOL

TOOLS REQUIRED

RATCHET

6" EXTENSION

3/4" SOCKET

11/16" SOCKET

15mm SOCKET

10mm SOCKET

PLIERS

DRILL /w 17/32" BIT

TORQUE WRENCH

FISHWIRE TECHNIQUE

INSERT COILED END OF FISHWIRE TOOL THROUGH HITCH MOUNTING HOLE IN VEHICLE FRAME RAIL AND OUT THE ACCESS HOLE. PASS COILED END OF FISHWIRE THROUGH SPACER AND THREAD BOLT INTO COIL. KINK WIRE TO KEEP SPACER SEPERATE FROM BOLT AS SHOWN. PULL FISHWIRE, SPACER, AND BOLT THROUGH FRAME AND OUT MOUNTING HOLE. USE FISHWIRE TO GUIDE HITCH DURING MOUNTING AND PREVENT LOSS OF BOLT / SPACER INSIDE FRAME RAIL.

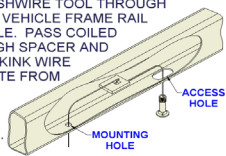

NOTE: SOME VEHICLES MAY FISHWIRE THROUGH END OF FRAME

HITCH WEIGHT: 33 LBS.

INSTALL TIME: 45 MINUTES

INSTALL NOTES:

- DRILLING REQUIRED
- LOWER EXHAUST
- CLEAN WELDNUTS
- LOWER LOAD LEVELING COMP.

USE HERE
ON SHORT WHEEL BASE
(2004 & OLDER)

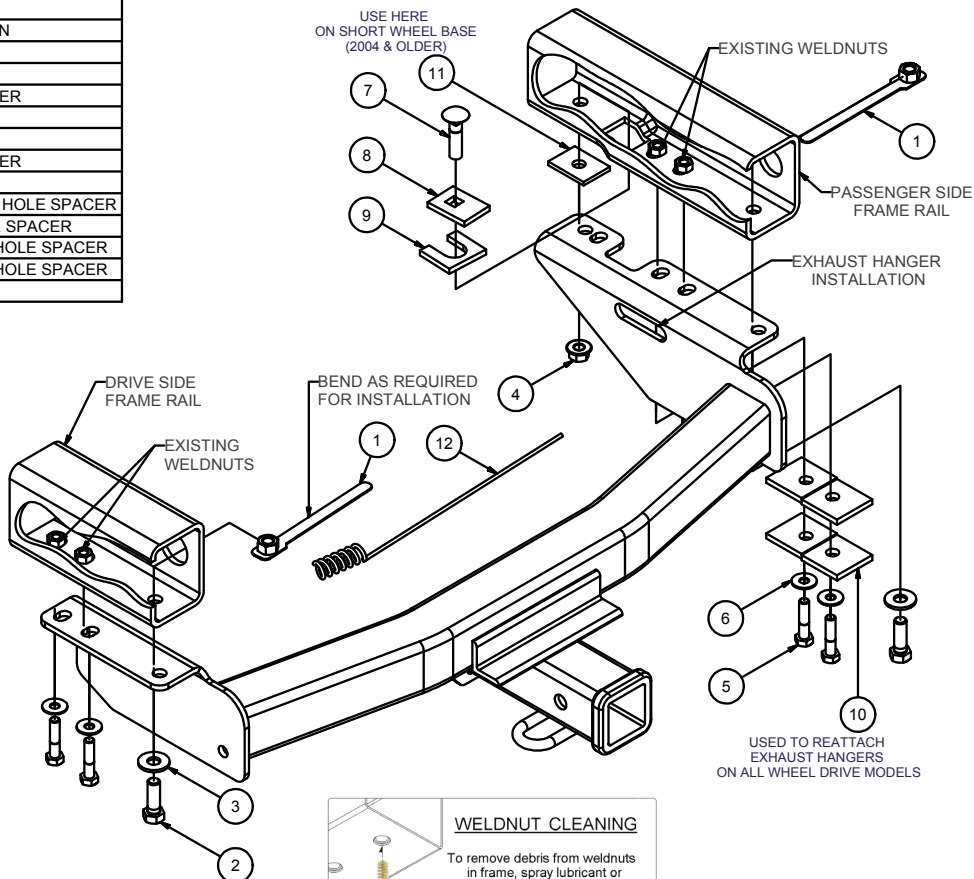
**WELDNUT CLEANING**

To remove debris from weldnuts in frame, spray lubricant or compressed air into hole. For heavy debris, use a small wire brush. (Be careful not to damage threads).

INSTALLATION STEPS

- 1) Lower vehicle exhaust by lowering the exhaust hanger on the passenger side.
- 2) If present, lower load leveling compressor on drivers side, (1) M10 bolt & (2) M6 nuts. **(Note: If necessary, trim vertical tab on compressor bracket to clear adjacent M10 bolt.)**
- 3) Raise hitch into position. Install M10-1.5 x 45mm bolts into existing weldnuts, both sides.
- 4) Using rearmost holes in hitch side plate as a template, drill 1/2" holes in vehicle frame rails. On *long wheel base* models: Its will be necessary to drill a 1/2" hole through forwardmost hole on the passenger side plate. On *short wheel base* models: Forwardmost hole in the passenger side plate will line up with existing slot in vehicle frame rail.
- 5) On passenger side, Fishwire carriage bolt and blocks through existing slot in frame rail down into forwardmost hole as shown. Secure using blocks, lock washer and nuts as follows. *Short wheel base models*: Place (2) spacer blocks between frame rail and hitch. *Long wheel base models*: Place (2) spacer blocks between hitch and flange nut as shown. There may be some unused spacers after installation is complete.
- 6) Install handle nut thru square hole in side of vehicle frame rail and install hex bolt and conical washer through rearmost hole as shown. **(Note: Drilled hole from step 4.)**
- 7) Remove M10 fasteners to reattach exhaust hanger and load leveling compressor, and reinstall fasteners. **(Note: On AWD models, it will be necessary to pass exhaust hanger through 3" long slot in side plate and use (2) 1/4" spacer blocks to reattach exhause hanger bracket.)**
- 8) Torque all 1/2" hardware to 110 lb-ft. Torque all M10 fasteners to 45 lb-ft. Torque all M6 fasteners to 9 lb-ft.

PERIODICALLY CHECK THIS RECEIVER HITCH TO ENSURE THAT ALL FASTENERS ARE TIGHT AND THAT ALL STRUCTURAL COMPONENTS ARE SOUND.

Curt Manufacturing Inc., warrants this product to be free of defects in material and/or workmanship at the time of retail purchase by the original purchaser. If the product is found to be defective, Curt Manufacturing Inc., may repair or replace the product, at their option, when the product is returned, prepaid, with proof of purchase. Alteration to, misuse of, or improper installation of this product voids the warranty. Curt Manufacturing Inc.'s liability is limited to repair or replacement of products found to be defective, and specifically excludes liability for incidental or consequential loss or damage.