



Safety glasses should be worn at all times while installing this product.

YEARS: 2013-PRESENT

MAKE: HYUNDAI

MODEL: SANTA FE (3.3L V6 MODELS)

STYLE: SUV

WARNING: NEVER EXCEED YOUR VEHICLE MANUFACTURER'S RECOMMENDED TOWING CAPACITY

WEIGHT CARRYING:
 TRAILER WEIGHT: 6,000 LBS.
 TONGUE WEIGHT: 900 LBS.

WEIGHT DISTRIBUTION:
 TRAILER WEIGHT: 8,000 LBS.
 TONGUE WEIGHT: 900 LBS.

PRO INSTALL TIME: 15 MIN.
NOVICE INSTALL TIME: 30 MIN.

IF YOU ARE HESITANT TO UNDERTAKE THIS TASK ON YOUR OWN, CONTACT AN AUTHORIZED CURT INSTALLER FOR ADDITIONAL ASSISTANCE.

INSTALLATION TIPS:

- BEFORE YOU BEGIN INSTALLATION, READ ALL INSTRUCTIONS THOROUGHLY.
- TO EASE INSTALLATION, 2 PEOPLE MAY BE REQUIRED.
- USING PROPER TOOLS WILL GREATLY IMPROVE THE QUALITY OF THE INSTALL AND REDUCE THE TIME REQUIRED.
- NEED HELP OR HAVE SOME QUESTIONS? CALL TECHNICAL SUPPORT AT 800.798.0813



INSTALLATION REQUIRES:

RATCHET	TORQUE WRENCH	6" SOCKET EXTENSION
3/4" 17mm SOCKET	SCREW DRIVER	SAFETY GLASSES

LEVEL OF DIFFICULTY: EASY

EASY	MODERATE	CHALLENGING
- NO DRILLING REQUIRED		
- LOWER SPARE TIRE		
- CLEAN EXISTING WELDNUTS		

HITCH ILLUSTRATION:

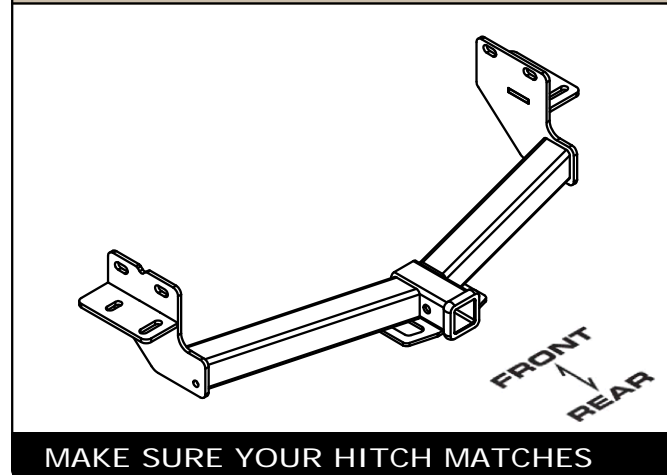

PERIODICALLY CHECK THIS RECEIVER HITCH TO ENSURE ALL FASTENERS ARE TIGHT AND ALL STRUCTURAL COMPONENTS ARE SOUND

CURT Manufacturing LLC. warrants this product to be free of defects in material and/or workmanship at the time of retail purchase by the original purchaser. If the product is found to be defective, Curt Manufacturing LLC. may repair or replace the product at their option, when the product is returned, prepaid, with proof of purchase. Alteration to, misuse of, or improper installation of this product voids the warranty. Curt Manufacturing LLC.'s liability is limited to repair or replacement of products found to be defective, and specifically excludes liability for incidental or consequential loss or damage.

For more information log onto www.curtmfg.com, & for helpful towing tips log onto www.hitchinfo.com

INSTALLATION WALKTHROUGH:

Parts List			
ITEM	QTY	PART NUMBER	DESCRIPTION
1	4	1/2-13 x 4 1/2	CARRIAGE BOLT
2	4	3/8"	CONICAL TOOTHED WASHER
3	4	HFN 1213, GR8	HEX FLANGE NUT
4	4	M10 - 1.25 x 25	HEX BOLT

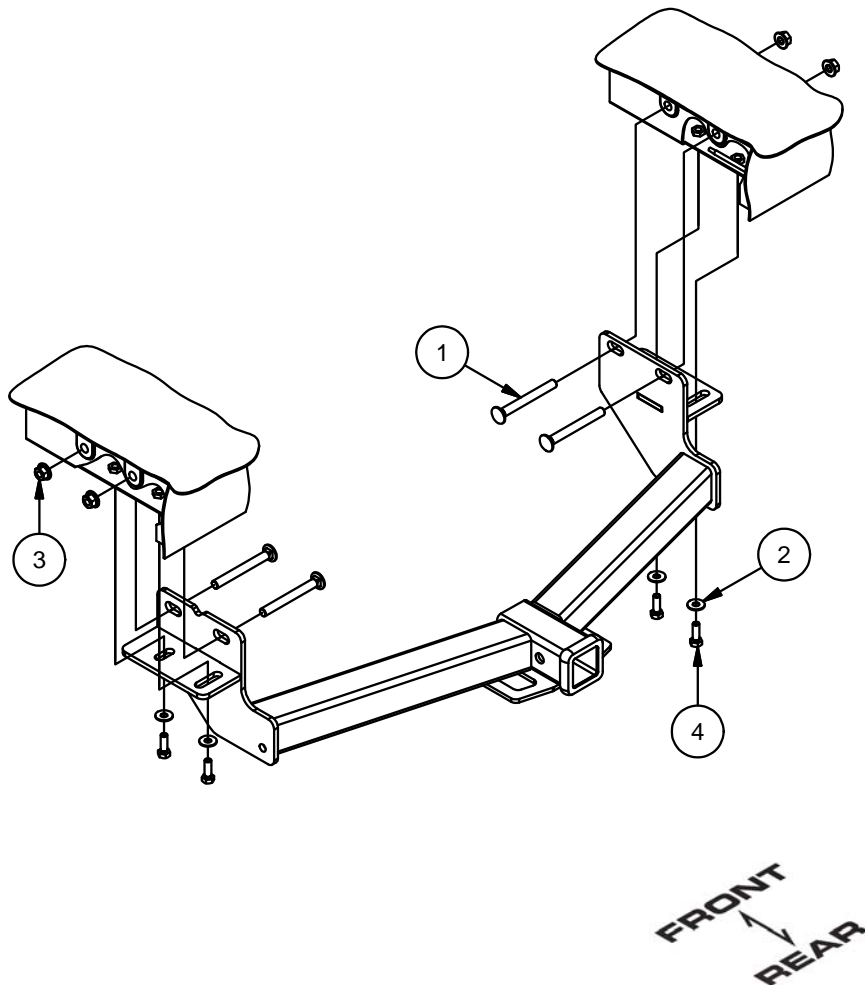

1. Remove (2) fascia screws and lower center bumper fascia panel. **Note:** Panel can be reinstated after hitch installation is complete.



2. Raise hitch into position and secure to the existing weldnuts with M10-1.25 x 25mm bolts and 3/8" conical toothed washers. **Note:** You may need to lower spare tire for additional clearance.



INSTALLATION WALKTHROUGH:

3. Insert 1/2-13 x 4 1/2" carriage bolts through the side plates and frame rails, secure using 1/2-13 flange nuts.
Note: You may need to bend or trim the bumper locator pin to allow hardware clearance.

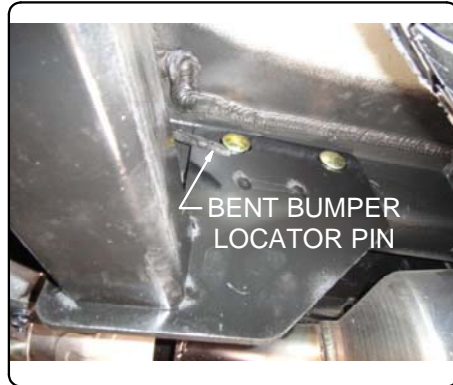
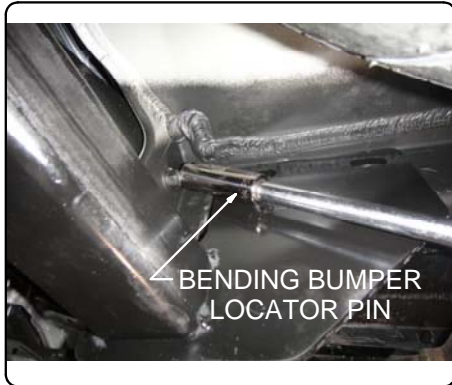

4. Torque all 1/2" hardware to 110 ft-lbs.
Torque all 10mm hardware to 48 ft-lbs.
If lowered, raise spare tire back into position.
Reinstall the bumper fascia panel removed in Step (1).

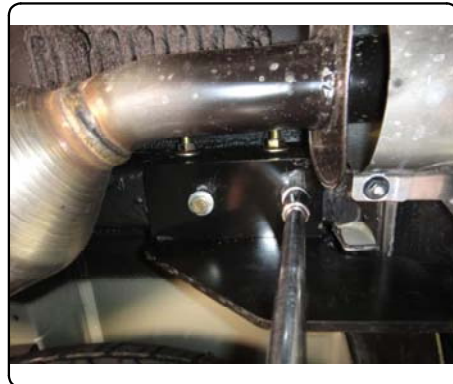

INSTALLATION COMPLETE



13153

HYUNDAI SANTA FE (3.3L V6 MODELS)

4/10/2013

GROSS LOAD CAPACITY WHEN USED AS A WEIGHT CARRYING HITCH: 6,000 LBS. TRAILER WEIGHT & 900 LBS. TONGUE WEIGHT.
 GROSS LOAD CAPACITY WHEN USED AS A WEIGHT DISTRIBUTION HITCH: 8,000 LBS. TRAILER WEIGHT & 900 LBS. TONGUE WEIGHT

DO NOT EXCEED VEHICLE MANUFACTURER'S RECOMMENDED TOWING CAPACITY.

HAVING INSTALLATION QUESTIONS? CALL TECHNICAL SUPPORT AT 1-800-798-0813

Parts List			
ITEM	QTY	PART NUMBER	DESCRIPTION
1	4	1/2-13 x 4 1/2	CARRIAGE BOLT
2	4	3/8"	CONICAL TOOTHED WASHER
3	4	HFN 1213, GR8	HEX FLANGE NUT
4	4	M10 - 1.25 x 25	HEX BOLT

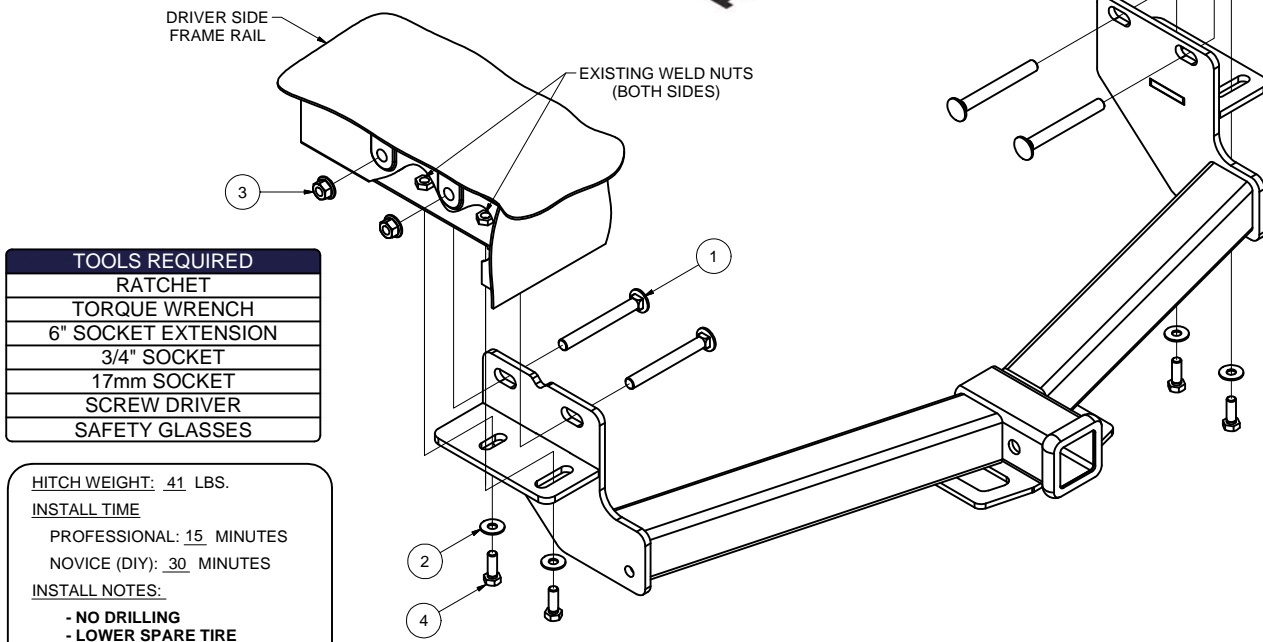
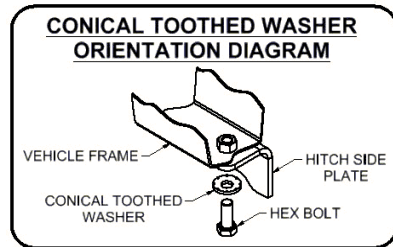
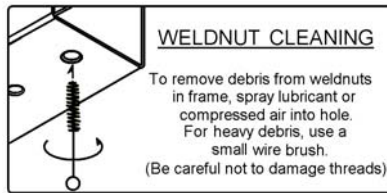

TOOLS REQUIRED
RATCHET
TORQUE WRENCH
6" SOCKET EXTENSION
3/4" SOCKET
17mm SOCKET
SCREW DRIVER
SAFETY GLASSES

HITCH WEIGHT: 41 LBS.

INSTALL TIME

PROFESSIONAL: 15 MINUTES

NOVICE (DIY): 30 MINUTES

INSTALL NOTES:

- NO DRILLING
- LOWER SPARE TIRE

INSTALLATION STEPS

1. Remove (2) fascia screws and lower center bumper fascia panel.
Note: Panel can be reinstalled after hitch installation is complete.
2. Raise hitch into position and secure to the existing weldnuts with M10-1.25 x 25mm bolts and 3/8" conical toothed washers. **Note:** You may need to lower spare tire for additional clearance.
3. Insert 1/2-13 x 4 1/2" carriage bolts through the side plates and frame rails, secure using 1/2-13 flange nuts.
Note: You may need to bend or trim the bumper locator pin to allow hardware clearance.
4. Torque all 1/2" hardware to 110 ft-lbs.
Torque all 10mm hardware to 48 ft-lbs.
5. If lowered, raise spare tire back into position. Reinstall the bumper fascia panel removed in Step (1).

PERIODICALLY CHECK THIS RECEIVER HITCH TO ENSURE THAT ALL FASTENERS ARE TIGHT AND THAT ALL STRUCTURAL COMPONENTS ARE SOUND.

Curt Manufacturing LLC., warrants this product to be free of defects in material and/or workmanship at the time of retail purchase by the original purchaser. If the product is found to be defective, Curt Manufacturing LLC., may repair or replace the product, at their option, when the product is returned, prepaid, with proof of purchase. Alteration to, misuse of, or improper installation of this product voids the warranty. Curt Manufacturing LLC.'s liability is limited to repair or replacement of products found to be defective, and specifically excludes liability for incidental or consequential loss or damage.