

**13077****BMW X5 AND X6**

10/8/2013

GROSS LOAD CAPACITY WHEN USED AS A WEIGHT CARRYING HITCH: 6,000 LBS. TRAILER WEIGHT & 600 LBS. TONGUE WEIGHT.  
 GROSS LOAD CAPACITY WHEN USED AS A WEIGHT DISTRIBUTION HITCH: 6,000 LBS. TRAILER WEIGHT & 600 LBS. TONGUE WEIGHT.

**\*\*\*DO NOT EXCEED VEHICLE MANUFACTURER'S RECOMMENDED TOWING CAPACITY.\*\*\***

**WARNING: ALL NON-TRAILER LOADS APPLIED TO THIS PRODUCT MUST BE SUPPORTED BY AUXILIARY STABILIZING STRAPS.**

**\*\* FAILURE TO PROPERLY SUPPORT NON-TRAILER LOADS WILL VOID PRODUCT WARRANTY\*\***

HAVING INSTALLATION QUESTIONS? CALL TECHNICAL SUPPORT AT 1-800-798-0813

Parts List			
ITEM	QTY	PART NUMBER	DESCRIPTION
1	8	M12 - 1.5 HEX NUT	HEX NUT
2	8	1/2"	CONICAL TOOTHED WASHER
3	4	PTR14	1/4" PUSH-TYPE RETAINER

**FRONT**  
**REAR**

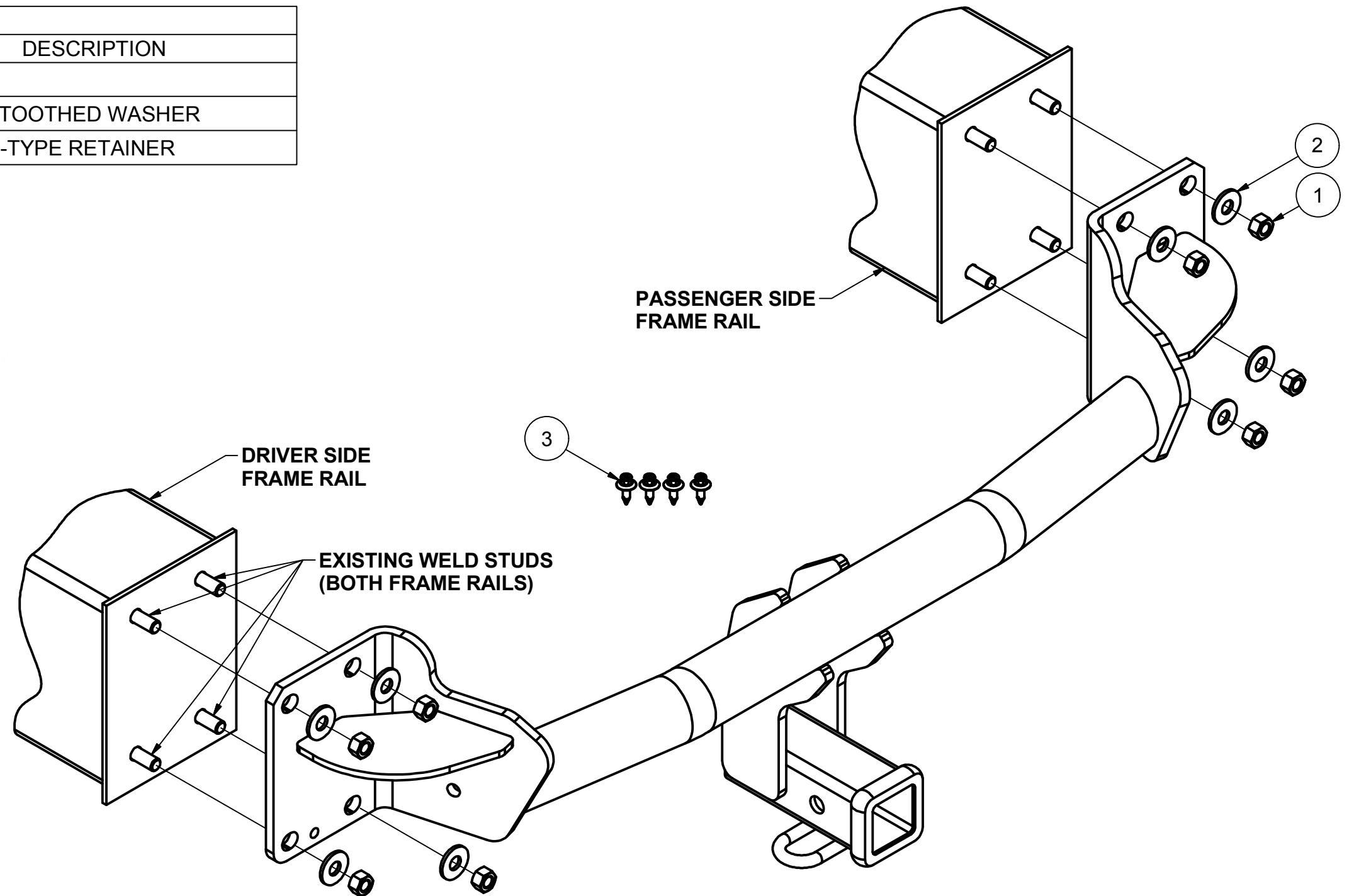

HITCH WEIGHT: 43 LBS.

INSTALL TIME

PROFESSIONAL: 90 MINUTES

NOVICE (DIY): 180 MINUTES

INSTALL NOTES:

- FASCIA TRIMMING REQUIRED
- NO DRILLING REQUIRED

## INSTALLATION STEPS

- 1) Remove lower bumper fascia. Remove the 2 plastic pop rivets from wheel well opening for each side, these can NOT be re-used. Gently pull back the molding to locate and remove bottom screw. (Note 2011 Remove 3 plastic push pins) Remove tail lights (3) 8mm nuts per side.
- 2) Remove the screw located behind each of the reflectors, (the reflector can be removed by releasing the clip that holds the reflector in place, access under bumper).
- 3) Remove the 6 screws located on the bottom of the bumper. Unplug back-up sensor harness if vehicle is equipped.
- 4) Gently pull the bumper ends outward and push the bumper forward. Remove and discard steel bumper beam and fasteners. Lowering tailgate to 45° angle allows access to upper mounting nuts.
- 5) Locate hitch into position and install with supplied fasteners as shown.
- 6) Torque all 12mm fasteners to 82 lb-ft.
- 7) With hitch on vehicle, mark bumper fascia and trim until fascia fits back onto vehicle without interfering with hitch.  
 NOTE: Watch for back-up sensor wires when trimming, the wires run along the fascia and could get cut.
- 8) Re-install bumper fascia onto vehicle with (4) 1/4" push-type retainers.

NOTE: OEM tow hooks can no longer be used at rear of vehicle.

**PERIODICALLY CHECK THIS RECEIVER HITCH TO ENSURE THAT ALL FASTENERS ARE TIGHT AND THAT ALL STRUCTURAL COMPONENTS ARE SOUND.**

Curt Manufacturing Inc., warrants this product to be free of defects in material and/or workmanship at the time of retail purchase by the original purchaser. If the product is found to be defective, Curt Manufacturing Inc., may repair or replace the product, at their option, when the product is returned, prepaid, with proof of purchase. Alteration to, misuse of, or improper installation of this product voids the warranty. Curt Manufacturing Inc.'s liability is limited to repair or replacement of products found to be defective, and specifically excludes liability for incidental or consequential loss or damage.