

13032**86-97 FORD AEROSTAR VAN**

5/20/2013

WILL NOT FIT WITH FULL SIZE SPARE TIRE

GROSS LOAD CAPACITY WHEN USED AS A WEIGHT CARRYING HITCH: 4,000 LBS. TRAILER WEIGHT & 400 LBS. TONGUE WEIGHT.
 GROSS LOAD CAPACITY WHEN USED AS A WEIGHT DISTRIBUTION HITCH: 6,000 LBS. TRAILER WEIGHT & 600 LBS. TONGUE WEIGHT

*****DO NOT EXCEED VEHICLE MANUFACTURER'S RECOMMENDED TOWING CAPACITY.*****

Parts List			
ITEM	QTY	PART NUMBER	DESCRIPTION
1	2	1/2"	CONICAL TOOTHED WASHER
2	4	1/2-13 x 1 3/4	CARRIAGE BOLT
3	1	1/2"	FISHWIRE TOOL
4	4	CM-SP40	.188 x 1.00 x 3.00" SQUARE HOLE SPACER
5	4	HFN 1213	HEX FLANGE NUT
6	2	1/2-13	HANDLE NUT
7	2	1/2-13 x 2"	HEX BOLT

FRONT
REAR

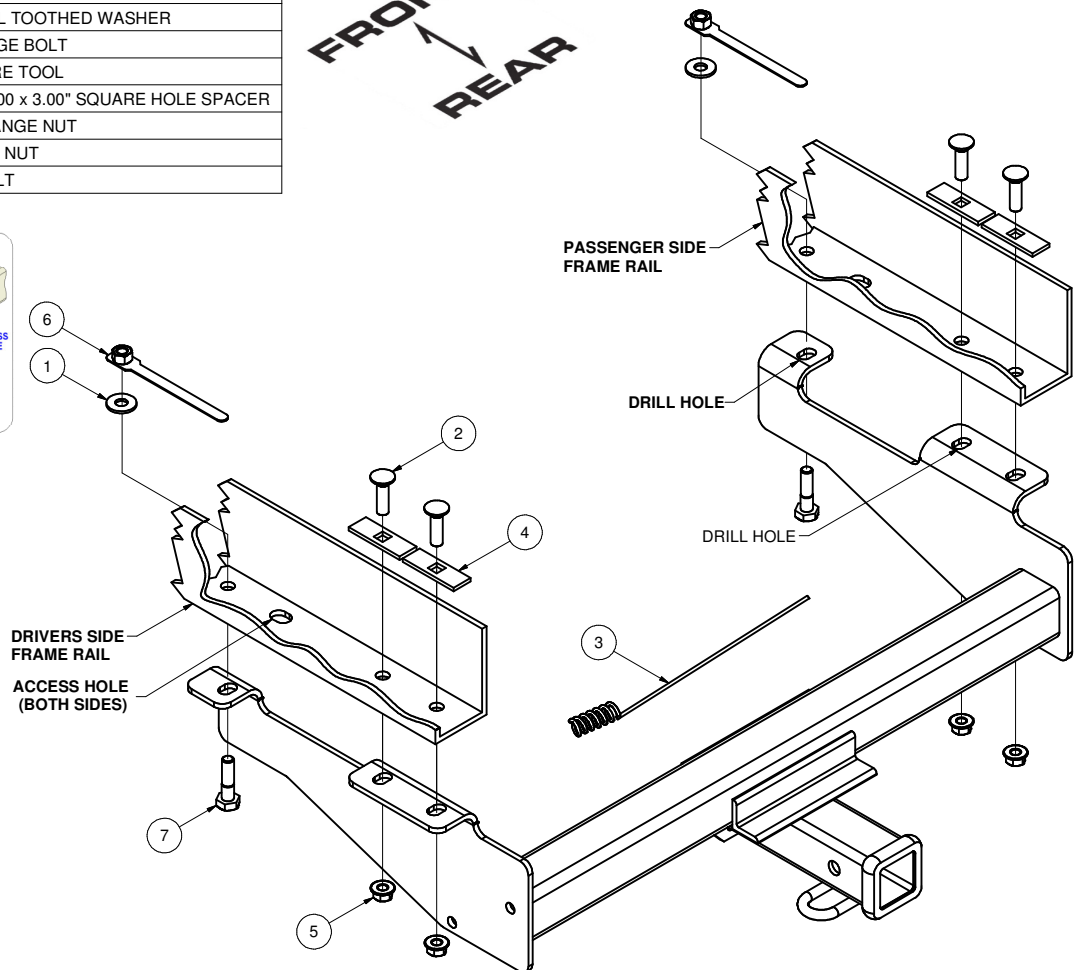
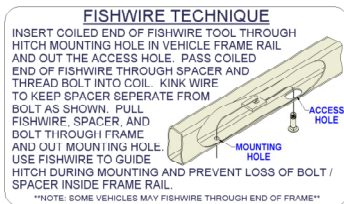

HITCH WEIGHT: 43 LBS.

INSTALL TIME: 45 MINUTES

INSTALL NOTES:

DRILLING REQUIRED**FISHWIRE HARDWARE**

INSTALLATION STEPS

**NOTE: MAKE SURE THERE ARE NO ELECTRICAL WIRES OR HOSES IN THE WAY.
 ALWAYS WEAR PROPER EYE PROTECTION WHEN DRILLING HOLES.**

- 1) Remove the rear bump stops. Position the receiver hitch and mark holes. Using the rear stock hole as a guide, position receiver so that rearward slots in receiver line up with the existing holes in vehicle frame. Using the receiver as a template, mark the remaining four holes.
- 2) Drill the four holes into the frame and fishwire the carriage bolts with the spacers into position through the access hole. Enlarge the existing holes in frame to 1/2".
- 3) Fasten hitch to vehicle as shown, position tab nuts to the frame through the stock access hole. Do not overtighten the rearward bolts through the frame.
- 4) Re-install the rubber axle bump stops. Torque all fasteners to 110 lb.-ft.

**PERIODICALLY CHECK THIS RECEIVER HITCH TO ENSURE THAT ALL FASTENERS
 ARE TIGHT AND THAT ALL STRUCTURAL COMPONENTS ARE SOUND.**

Curt Manufacturing Inc., warrants this product to be free of defects in material and/or workmanship at the time of retail purchase by the original purchaser. If the product is found to be defective, Curt Manufacturing Inc., may repair or replace the product, at their option, when the product is returned, prepaid, with proof of purchase. Alteration to, misuse of, or improper installation of this product voids the warranty. Curt Manufacturing Inc.'s liability is limited to repair or replacement of products found to be defective, and specifically excludes liability for incidental or consequential loss or damage.