

YEARS: 2011-PRESENT

MAKE: NISSAN

MODEL: JUKE (AWD MODELS) (EXCLUDES NISMO)

STYLE: CROSSOVER

**WARNING: NEVER EXCEED YOUR VEHICLE MANUFACTURER'S RECOMMENDED TOWING CAPACITY**

**WEIGHT CARRYING:**  
 TRAILER WEIGHT: 2,000 LBS.  
 TONGUE WEIGHT: 200 LBS.

**WARNING:**  
 WE RECOMMEND THE USE OF 18050 STABILIZING STRAPS FOR ALL NON-TRAILER (WHEEL-LESS) LOADS. PLEASE SEE THE CURT CATALOG OR VISIT US ONLINE AT [WWW.CURTMFG.COM](http://WWW.CURTMFG.COM) FOR FURTHER INFORMATION.

**INSTALLATION TIME: 30 MIN.**

THE INSTALL TIME LISTED IS FOR PROFESSIONAL INSTALLERS. IF YOU ARE HESITANT TO UNDERTAKE THIS TASK ON YOUR OWN, CONTACT AN AUTHORIZED CURT INSTALLER FOR ADDITIONAL ASSISTANCE.

**INSTALLATION REQUIRES:**

		17mm 18mm 20mm
RATCHET	TORQUE WRENCH	SOCKET
8" SOCKET EXTENSION	PRY BAR	

**INSTALLATION TIPS:**

- BEFORE YOU BEGIN INSTALLATION, READ ALL INSTRUCTIONS THOROUGHLY.
- TO EASE INSTALLATION, 2 PEOPLE MAY BE REQUIRED.
- USING PROPER TOOLS WILL GREATLY IMPROVE THE QUALITY OF THE INSTALL AND REDUCE THE TIME REQUIRED.
- NEED HELP OR HAVE SOME QUESTIONS? CALL TECHNICAL SUPPORT AT 800.798.0813

**LEVEL OF DIFFICULTY: EASY**

EASY	MODERATE	HARD
	NO DRILLING REQUIRED	
	LOWER EXHAUST	
	REMOVE TOW LOOP	

**VEHICLE PHOTO:**



REPRESENTATIVE PHOTO

**HITCH ILLUSTRATION:**

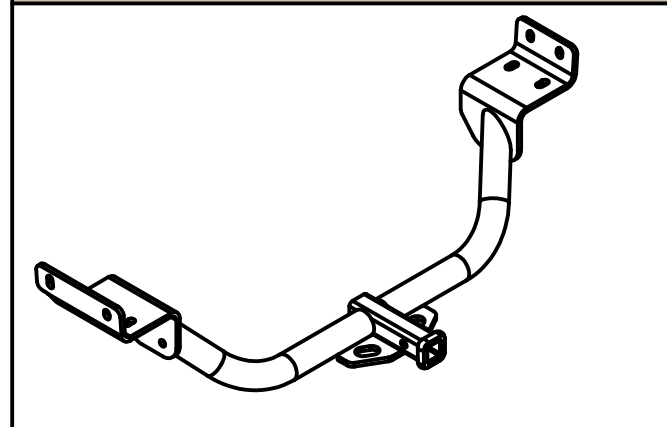

MAKE SURE YOUR HITCH MATCHES

**PERIODICALLY CHECK THIS RECEIVER HITCH TO ENSURE ALL FASTENERS ARE TIGHT AND ALL STRUCTURAL COMPONENTS ARE SOUND**

CURT Manufacturing Inc. warrants this product to be free of defects in material and/or workmanship at the time of retail purchase by the original purchaser. If the product is found to be defective, Curt Manufacturing Inc. may repair or replace the product at their option, when the product is returned, prepaid, with proof of purchase. Alteration to, misuse of, or improper installation of this product voids the warranty. Curt Manufacturing Inc.'s liability is limited to repair or replacement of products found to be defective, and specifically excludes liability for incidental or consequential loss or damage.

## INSTALLATION WALKTHROUGH:

Parts List			
ITEM	QTY	PART NUMBER	DESCRIPTION
1	4	M10 - 1.25 x 30	HEX BOLT
2	4	7/16"	CONICAL TOOTHED WASHER
3	4	M12-1.25 x 30mm	HEX BOLT
4	4	1/2"	CONICAL TOOTHED WASHER

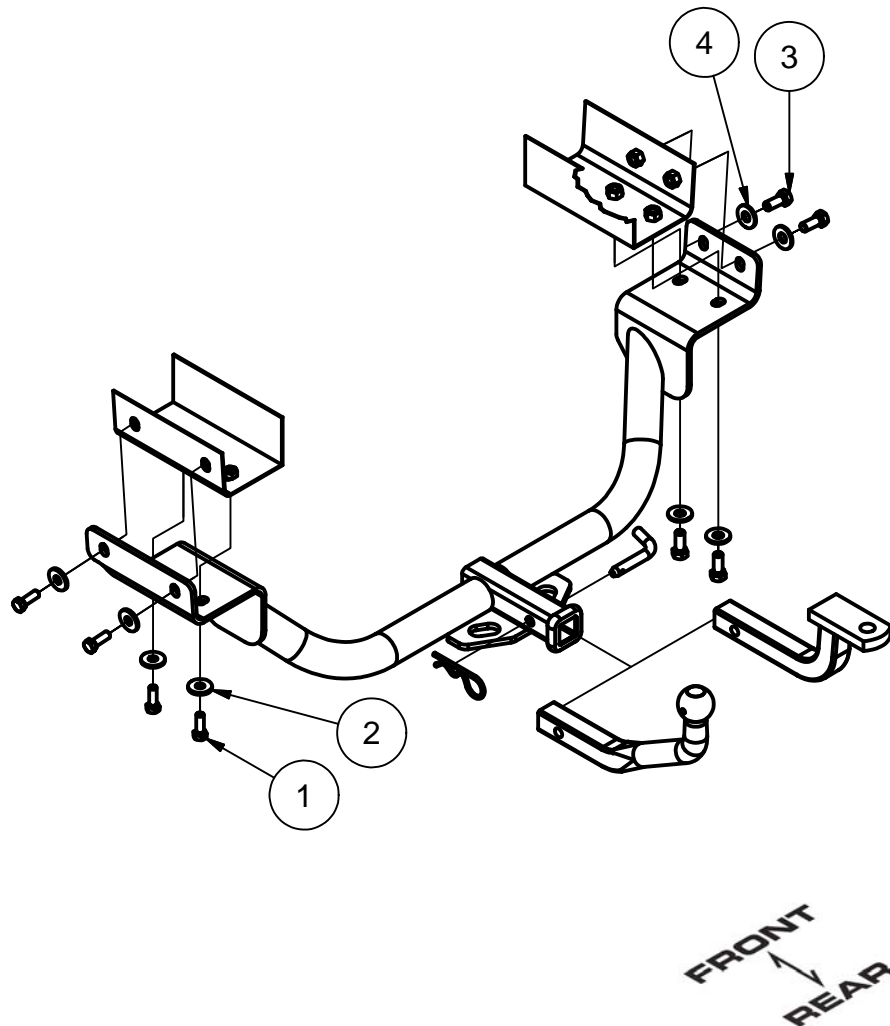

1. Remove existing tow loop from passenger side of vehicle. Return tow loop and hardware to vehicle owner.



2. Lower exhaust by removing (3) rubber isolators from the muffler. Use wire to hold up exhaust enough to prevent damage.



## INSTALLATION WALKTHROUGH:

3. Raise hitch into position and secure with supplied hardware as shown.



4. Torque M12-1.25 hardware to 110 lb-ft and M10-1.25 hardware to 40 lb-ft.



5. Raise exhaust back into position.



# 11088 NISSAN JUKE (AWD MODELS, EXCLUDING NISMO)

10/14/13

GROSS LOAD CAPACITY WHEN USED AS A WEIGHT CARRYING HITCH: 2,000 LBS. TRAILER WEIGHT & 200 LBS. TONGUE WEIGHT.

\*\*\*DO NOT EXCEED VEHICLE MANUFACTURER'S RECOMMENDED TOWING CAPACITY.\*\*\*

**WARNING: ALL NON-TRAILER LOADS APPLIED TO THIS PRODUCT MUST BE SUPPORTED BY 18050 STABILIZING STRAPS.**

\*\* FAILURE TO PROPERLY SUPPORT NON-TRAILER LOADS WILL VOID PRODUCT WARRANTY\*\*

HAVING INSTALLATION QUESTIONS? CALL TECHNICAL SUPPORT AT 1-800-798-0813

Parts List			
ITEM	QTY	PART NUMBER	DESCRIPTION
1	4	M10 - 1.25 x 30	HEX BOLT
2	4	7/16"	CONICAL TOOTHED WASHER
3	4	M12-1.25 x 30mm	HEX BOLT
4	4	1/2"	CONICAL TOOTHED WASHER

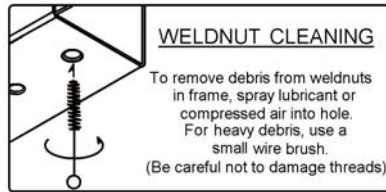

TOOLS REQUIRED
SOCKET WRENCH
TORQUE WRENCH
17mm SOCKET
18mm SOCKET
20mm SOCKET
8" SOCKET EXTENSION
PRYBAR

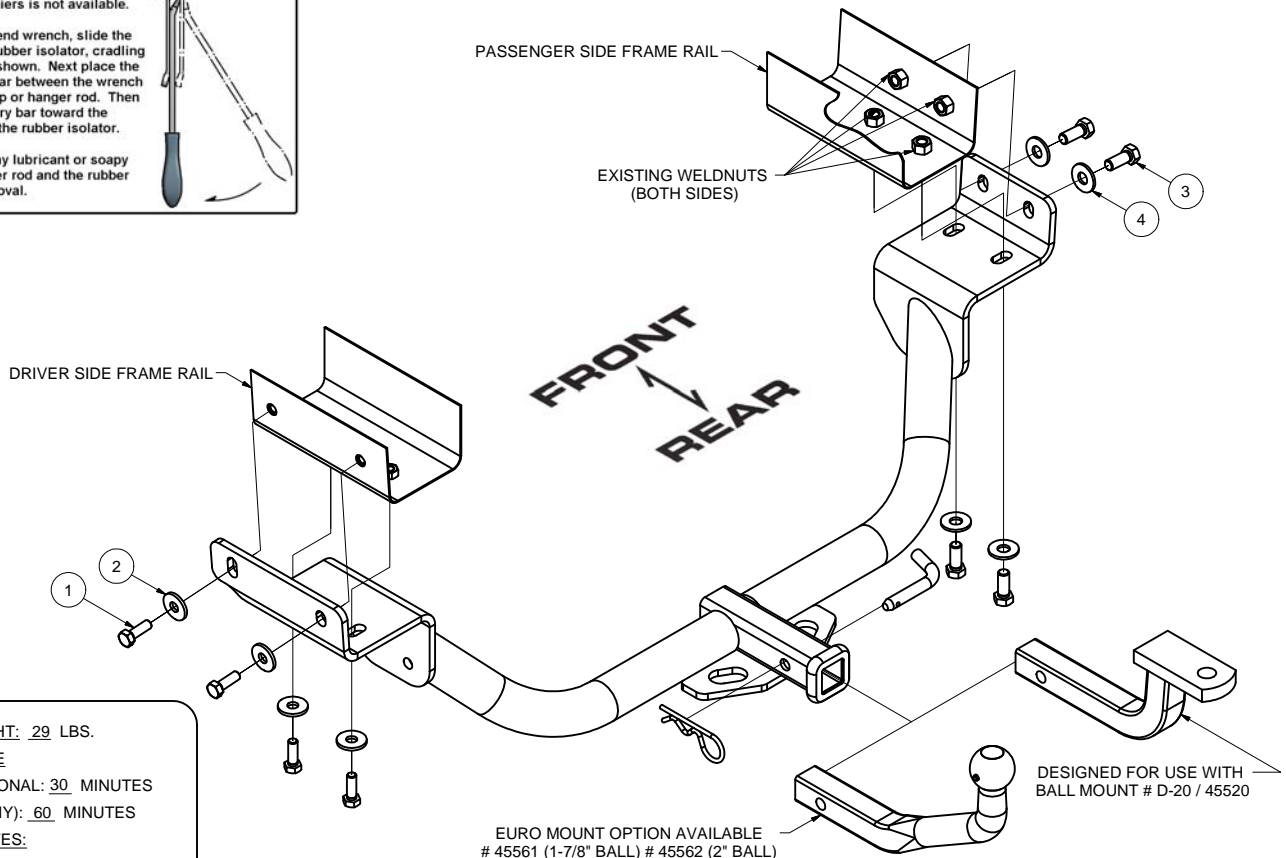
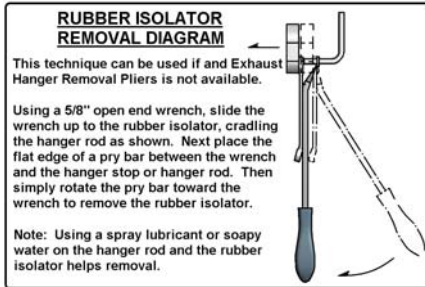

HITCH WEIGHT: 29 LBS.

**INSTALL TIME**

PROFESSIONAL: 30 MINUTES

NOVICE (DIY): 60 MINUTES

**INSTALL NOTES:**

- REMOVE EXISTING TOW LOOP
- LOWER EXHAUST
- NO DRILLING REQUIRED

## INSTALLATION STEPS

1. Remove factory tow loop on passenger side of the vehicle. Return tow loop and hardware to vehicle owner.
2. Lower exhaust by removing (3) rubber isolators. (See RUBBER ISOLATOR REMOVAL DIAGRAM) Wire may be used to hold the exhaust to prevent damage if lowered too far.
3. Raise hitch into position and secure hitch with supplied hardware as shown.
4. Torque M12-1.25 hardware to 86 lb-ft and M10-1.25 hardware to 48 lb-ft.
5. Raise exhaust back into position.

PERIODICALLY CHECK THIS RECEIVER HITCH TO ENSURE THAT ALL FASTENERS ARE TIGHT AND THAT ALL STRUCTURAL COMPONENTS ARE SOUND.

Curt Manufacturing Inc., warrants this product to be free of defects in material and/or workmanship at the time of retail purchase by the original purchaser. If the product is found to be defective, Curt Manufacturing Inc., may repair or replace the product, at their option, when the product is returned, prepaid, with proof of purchase. Alteration to, misuse of, or improper installation of this product voids the warranty. Curt Manufacturing Inc.'s liability is limited to repair or replacement of products found to be defective, and specifically excludes liability for incidental or consequential loss or damage.