

YEARS: 2017-CURRENT

MAKE: HONDA

MODEL: RIDGELINE

STYLE: TRUCK

WARNING: NEVER EXCEED YOUR VEHICLE MANUFACTURER'S RECOMMENDED TOWING CAPACITY
 For more information log onto www.curtmfg.com & for helpful towing tips log onto www.hitchinfo.com

WEIGHT CARRYING:
 TRAILER WEIGHT: 5,000 LBS.
 TONGUE WEIGHT: 500 LBS.

GROSS LOAD CAPACITY WHEN USED AS A STRAIGHT LINE PULL:
 9,000 LBS MAX.

PRO INSTALL TIME: 30 MIN.
NOVICE INSTALL TIME: 60 MIN.

IF YOU ARE HESITANT TO UNDERTAKE THIS TASK ON YOUR OWN, CONTACT AN AUTHORIZED CURT INSTALLER FOR ADDITIONAL ASSISTANCE.

INSTALLATION REQUIRES:

RATCHET	10mm 17mm 19mm 3/4" SOCKET	TORQUE WRENCH
6" SOCKET EXTENSION	DRILL BIT 11/16"	POWER DRILL
FLAT HEAD SCREW DRIVER	PHILLIPS SCREW DRIVER	

INSTALLATION TIPS:

- BEFORE YOU BEGIN INSTALLATION, READ ALL INSTRUCTIONS THOROUGHLY.
- TO EASE INSTALLATION, 2 PEOPLE MAY BE REQUIRED.
- USING PROPER TOOLS WILL GREATLY IMPROVE THE QUALITY OF THE INSTALL AND REDUCE THE TIME REQUIRED.
- NEED HELP OR HAVE SOME QUESTIONS? CALL TECHNICAL SUPPORT AT 800.798.0813

LEVEL OF DIFFICULTY: MODERATE

EASY	MODERATE	CHALLENGING
PART REMOVAL	UNDERBODY PANEL REMOVAL	
	HOLE ENLARGEMENT REQUIRED	

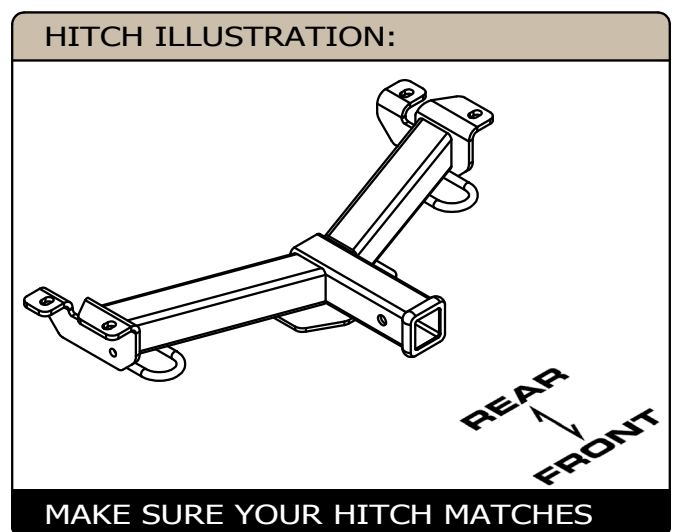

PERIODICALLY CHECK THIS RECEIVER HITCH TO ENSURE ALL FASTENERS ARE TIGHT AND ALL STRUCTURAL COMPONENTS ARE SOUND
 CURT Manufacturing LLC. warrants this product to be free of defects in material and/or workmanship at the time of retail purchase by the original purchaser. If the product is found to be defective, CURT Manufacturing LLC. may repair or replace the product at their option, when the product is returned, prepaid, with proof of purchase. Alteration to, misuse of, or improper installation of this product voids the warranty. CURT Manufacturing LLC.'s liability is limited to repair or replacement of products found to be defective, and specifically excludes liability for incidental or consequential loss or damage.
 For more information log onto www.curtmfg.com, & for helpful towing tips log onto www.hitchinfo.com
 This product complies with safety specifications and requirements for connecting devices and towing systems of the state of New York, V.E.S.C.Regulation V-5 and SAE J684.

INSTALLATION WALKTHROUGH:

Parts List			
ITEM	QTY	PART NUMBER	DESCRIPTION
1	2	1/2-13 x 1 3/4	HEX BOLT
2	4	1/2	CONICAL TOOTHED WASHER
3	2	1_2 - 13	RIVET NUT
4	4	CM-SP50	.250 x 1.00 x 1.50" ROUND HOLE SPACER
5	2	M12 - 1.25 x 40 HEX	HEX BOLT
6	2	1/2"	LOCK WASHER

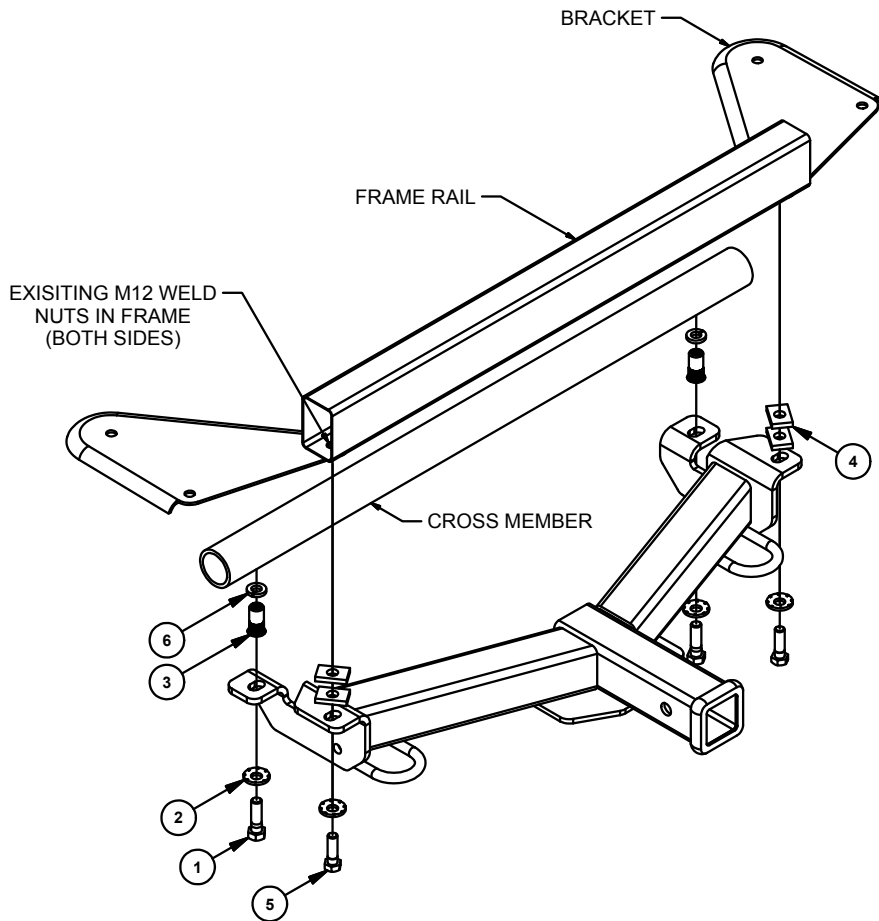

1. Using a flat head screwdriver, remove (5) plastic push pins from center area of fascia. Using a 10mm socket, remove (8) bolts from center area of fascia.

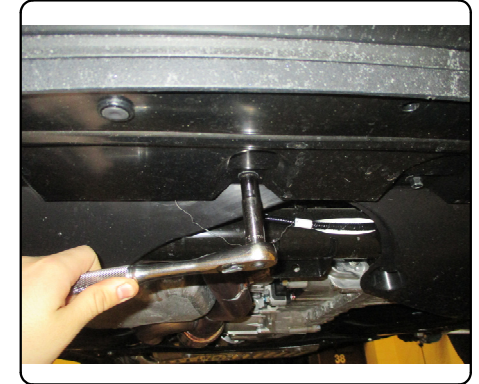

2. Remove (2) plastic push pins from crossmember, (1) on each side. Using a phillips screwdriver, remove (2) screws from vehicle panel, (1) on each side. Remove panel and return to owner.



INSTALLATION WALKTHROUGH:

3. Using a 17mm socket, remove (1) M12 bolt from bracket on each frame rail. Return bolt to owner. Locate holes at end of each cross member. Using a 11/16" drill, enlarge holes and insert rivet nut into enlarged holes. Re-install (4) black hex bolts removed from center fascia in STEP 2.



4. Raise hitch into position. Loosely install M12 x 40mm bolt with a conical toothed washer with (2) CM-SP50 spacers placed on top of each side plate and in between vehicle bracket and side plate.



5. To set rivet nut, hold hitch tight against cross member and tighten 1/2"-13 hex bolt to **50 ft-lbs**.

NOTE: If rivet nut spins in hole and is not tight, place 1/2" lock washer between hitch and rivet nut. Torque bolt to **50 ft-lbs** to set rivet nut. Next, loosen bolt, remove lock washer, and reinstall 1/2"-13 hex bolt with conical toothed washer.

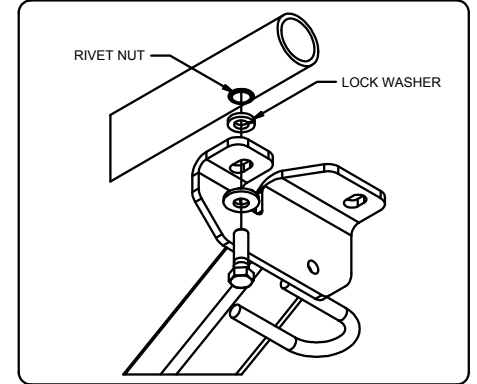

6. 1/2"-13 hex bolt to **50 ft-lbs**. Torque all M12 fasteners to **76 ft-lbs**.

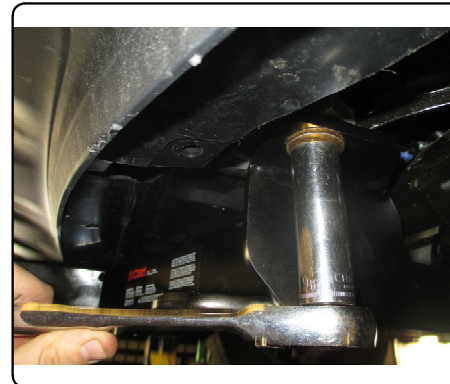

GROSS LOAD CAPACITY WHEN USED AS A WEIGHT CARRYING HITCH: 5,000 LBS. TRAILER WEIGHT & 500 LBS. TONGUE WEIGHT.

WARNING: ALL NON-TRAILER LOADS APPLIED TO THIS PRODUCT MUST BE SUPPORTED BY 18050 STABILIZING STRAPS.



WARNING: ** FAILURE TO PROPERLY SUPPORT NON-TRAILER LOADS WILL VOID PRODUCT WARRANTY **

WARNING: * DO NOT EXCEED VEHICLE MANUFACTURER'S RECOMMENDED TOWING CAPACITY *****

FOR MORE INFORMATION LOG ONTO WWW.CURTMFG.COM & FOR HELPFUL TOWING TIPS LOG ONTO WWW.HITCHINFO.COM
HAVING INSTALLATION QUESTIONS? CALL TECHNICAL SUPPORT AT 1-800-798-0813



Parts List			
ITEM	QTY	PART NUMBER	DESCRIPTION
1	2	1/2-13 x 1 3/4	HEX BOLT
2	4	1/2	CONICAL TOOTHED WASHER
3	2	1_2 - 13	RIVET NUT
4	4	CM-SP50	.250 x 1.00 x 1.50" ROUND HOLE SPACER
5	2	M12 - 1.25 x 40 HEX	HEX BOLT
6	2	1/2"	LOCK WASHER

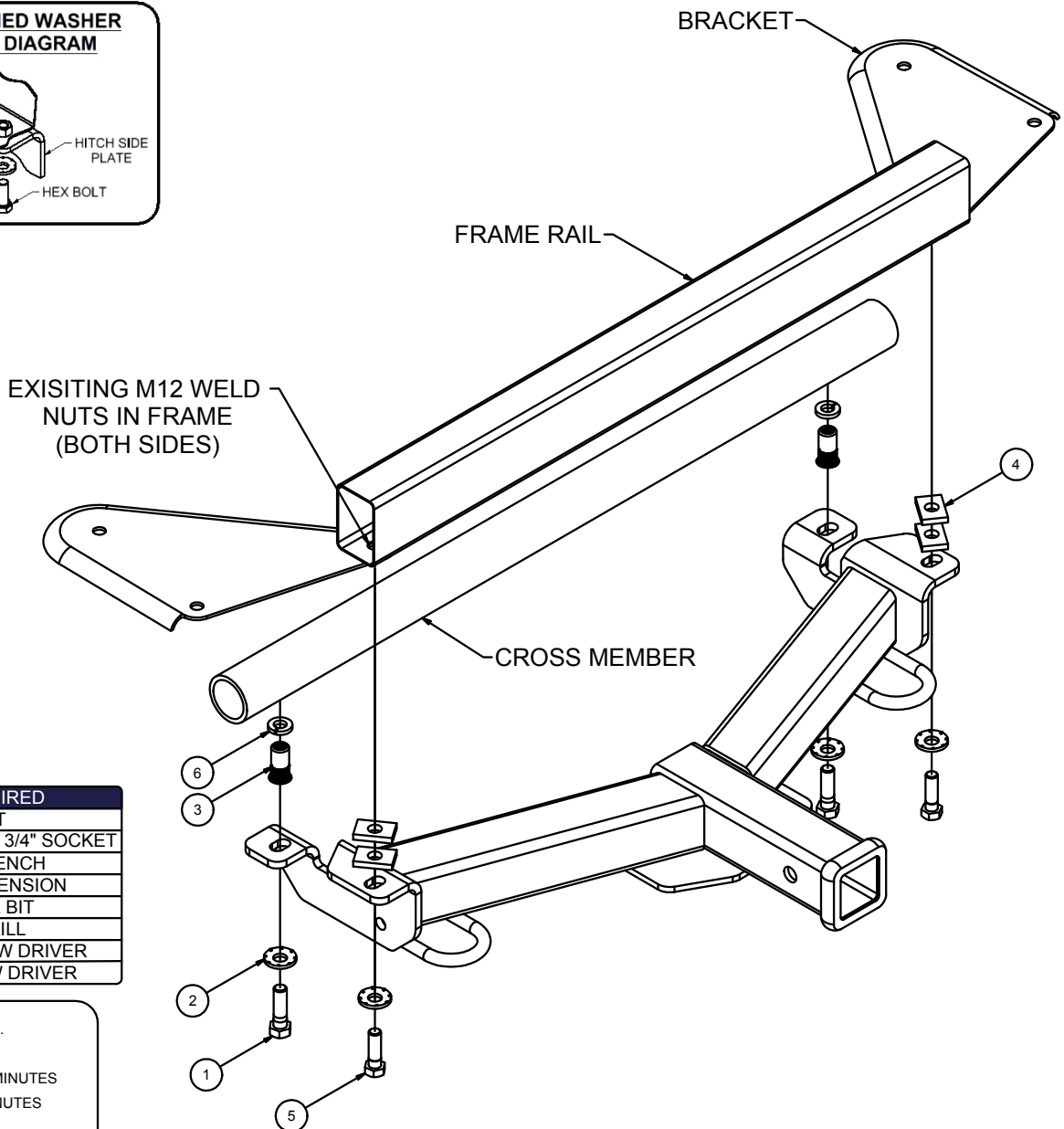
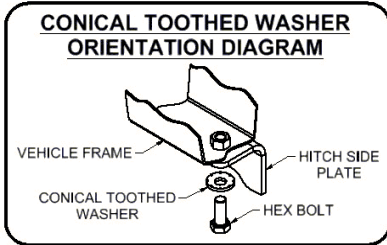
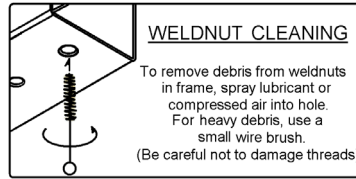

TOOLS REQUIRED
RATCHET
10mm, 17mm, 19mm & 3/4" SOCKET
TORQUE WRENCH
6" SOCKET EXTENSION
11/16" DRILL BIT
POWER DRILL
FLAT HEAD SCREW DRIVER
PHILLIPS SCREW DRIVER

HITCH WEIGHT: 27 LBS.
INSTALL TIME
PROFESSIONAL: 30 MINUTES
NOVICE (DIY): 60 MINUTES
INSTALL NOTES:
UNDERBODY PANEL REMOVAL
HOLE ENLARGEMENT REQUIRED
NO TRIMMING REQUIRED

PERIODICALLY CHECK THIS RECEIVER HITCH TO ENSURE THAT ALL FASTENERS ARE TIGHT AND THAT ALL STRUCTURAL COMPONENTS ARE SOUND.



Scan for more information

CURT Manufacturing LLC., warrants this product to be free of defects in material and/or workmanship at the time of retail purchase by the original purchaser. If the product is found to be defective, CURT Manufacturing LLC., may repair or replace the product, at their option, when the product is returned, prepaid, with proof of purchase. Alteration to, misuse of, or improper installation of this product voids the warranty. CURT Manufacturing LLC.'s liability is limited to repair or replacement of products found to be defective, and specifically excludes liability for incidental or consequential loss or damage.

This product complies with safety specifications and requirements for connecting devices and towing systems of the state of New York, V.E.S.C.Regulation V-5 and SAE J684.

INSTALLATION STEPS

1. Using a flat head screwdriver, remove (5) plastic push pins from center area of fascia
 2. Using a 10mm socket, remove (8) bolts from center area of fascia.
 3. Remove (2) more plastic push pins from cross member, (1) on each side.
 4. Using a phillips screwdriver, remove (2) screws from vehicle panel, (1) on each side.
 5. Remove panel and return to owner.
 6. Using a 17mm socket, remove (1) M12 bolt from bracket on each frame rail. Return bolts to owner. Re-install (4) black hex bolts removed from center fascia in STEP 2.
 7. Locate holes at each end of cross member. Using a 11/16" drill, enlarge holes and insert rivet nut into enlarged holes.
 8. Raise hitch into position. Loosely install M12 x 40mm bolt and conical toothed washer with (2) CM-50 spacers placed on top of each side plate and in between vehicle bracket and side plate.
 9. To set rivet nut, hold hitch tight against cross member and tighten 1/2"-13 hex bolt to **50 ft-lbs**.
- NOTE:** If rivet nut spins in hole and is not tight, place 1/2" lock washer between hitch and rivet nut. Torque bolt to 50 ft-lbs to set rivet nut. Next, loosen bolt, remove lock washer, and reinstall 1/2"-13 hex bolt with conical toothed washer.
10. Torque all 1/2" fasteners to **50 ft-lbs** and all M12 fasteners to **76 ft-lbs**.

PERIODICALLY CHECK THIS RECEIVER HITCH TO ENSURE THAT ALL FASTENERS ARE TIGHT AND THAT ALL STRUCTURAL COMPONENTS ARE SOUND.

CURT Manufacturing LLC., warrants this product to be free of defects in material and/or workmanship at the time of retail purchase by the original purchaser. If the product is found to be defective, CURT Manufacturing LLC., may repair or replace the product, at their option, when the product is returned, prepaid, with proof of purchase. Alteration to, misuse of, or improper installation of this product voids the warranty. CURT Manufacturing LLC.'s liability is limited to repair or replacement of products found to be defective, and specifically excludes liability for incidental or consequential loss or damage.

This product complies with safety specifications and requirements for connecting devices and towing systems of the state of New York, V.E.S.C.Regulation V-5 and SAE J684.

DO NOT EXCEED VEHICLE MANUFACTURER'S RECOMMENDED TOWING CAPACITY.

FRONT MOUNTED ACCESSORIES

1) Do not exceed front axle Gross Weight Rating (GAWR). Consult owners manual or specification plate located on driver's door frame. Measure gross front axle weight by placing front wheels of loaded vehicle on a scale.

WARNING: Exceeding GAWR may overload the front axle and/or suspension. This could result in **accident, property damage and personal injury.**

- 2) Reposition front mounted license plate if obstructed.
- 3) Do not obstruct vehicle lights.
- 4) Allow free air flow into grille opening.
- 5) Rear wheel traction may be reduced. This could effect handling. Reduce speed and drive with caution.
- 6) Accessories extend front of vehicle. This may reduce approach angle. Use caution when parking and maneuvering.
- 7) Do not obstruct driver view.

VEHICLE RECOVERY AND WINCHING TIPS

1) Use OEM tow hooks, recovery eyes or a clevis mount for attachment of a tow strap or winch cable.

WARNING: NEVER use a ball and/or ball mount as an anchor point for tow strap or winch cable. Severe personal injury or death could result.

- 2) Observe winch manufacturer's recommendations, cautions and warnings.
- 3) Attach return cable to tow hook or recovery eye when using a snatch block (See figure 1).

CAUTION: Do not attach return cable to winch mount. This may overload winch mount and/or front mounted receiver.

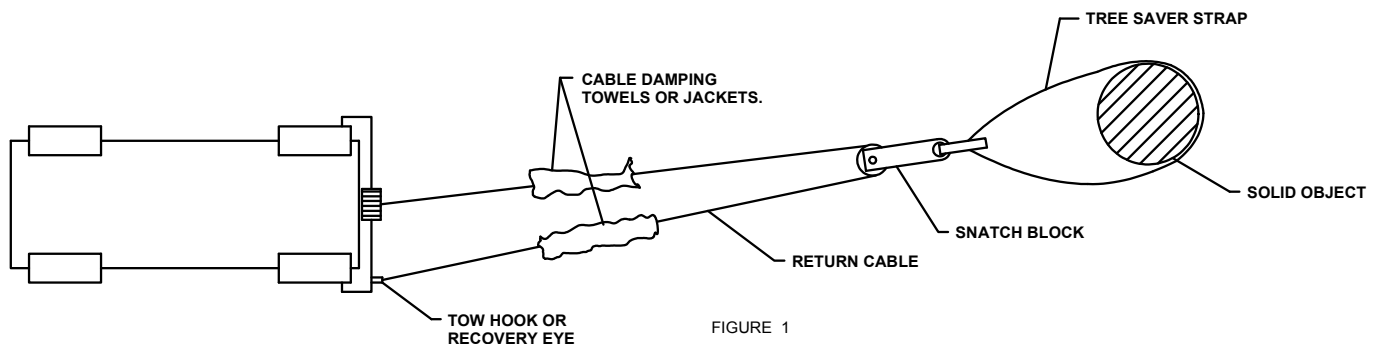

RATING

For **Maximum** line pull rating, winch cable must not exceed:

- 15 degree angle up or down from horizontal (See Figure 2).
- 45 degree angle left or right from straight ahead (See Figure 3).

CAUTION: Exceeding the maximum line pull rating may over load winch, winch mount, and/or front mounted receiver.

