



Safety glasses should be worn at all times while installing this product.

YEARS: 2015

MAKE: CHEVROLET

MODEL: COLORADO & CANYON

STYLE: TRUCK

**WARNING: NEVER EXCEED YOUR VEHICLE MANUFACTURER'S RECOMMENDED TOWING CAPACITY**





**WEIGHT CARRYING:**  
 TRAILER WEIGHT: 5,000 LBS.  
 TONGUE WEIGHT: 500 LBS.

**GROSS LOAD CAPACITY WHEN USED AS A STRAIGHT LINE PULL:**  
 9,000 LBS MAX.

**PRO INSTALL TIME: 45 MIN.**  
**NOVICE INSTALL TIME: 90 MIN.**

IF YOU ARE HESITANT TO UNDERTAKE THIS TASK ON YOUR OWN, CONTACT AN AUTHORIZED CURT INSTALLER FOR ADDITIONAL ASSISTANCE.



**INSTALLATION REQUIRES:**

 <b>RATCHET</b>	 <b>TORQUE WRENCH</b>	 <b>AVIATION SHEARS</b>
 <b>11/16" 15mm 10mm SOCKET</b>	<b>11/16" OPEN END WRENCH</b>	

**INSTALLATION TIPS:**

- BEFORE YOU BEGIN INSTALLATION, READ ALL INSTRUCTIONS THOROUGHLY.
- TO EASE INSTALLATION, 2 PEOPLE MAY BE REQUIRED.
- USING PROPER TOOLS WILL GREATLY IMPROVE THE QUALITY OF THE INSTALL AND REDUCE THE TIME REQUIRED.
- NEED HELP OR HAVE SOME QUESTIONS? CALL TECHNICAL SUPPORT AT 800.798.0813

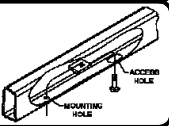
**LEVEL OF DIFFICULTY: MODERATE**

EASY	MODERATE	CHALLENGING
	FASCIA TRIMMING	
	FISHWIRE REQUIRED	
	OPTIONAL SKID PLATE TRIM AND REPLACE	

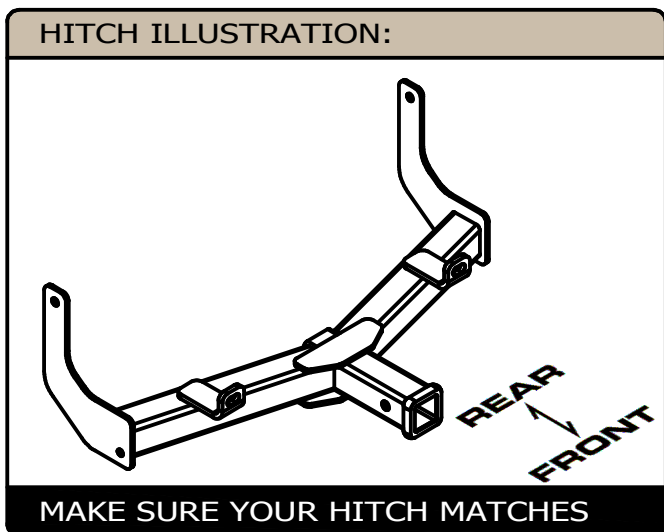

SCAN FOR MORE INFO

PERIODICALLY CHECK THIS RECEIVER HITCH TO ENSURE ALL FASTENERS ARE TIGHT AND ALL STRUCTURAL COMPONENTS ARE SOUND  
 CURT Manufacturing LLC. warrants this product to be free of defects in material and/or workmanship at the time of retail purchase by the original purchaser. If the product is found to be defective, CURT Manufacturing LLC. may repair or replace the product at their option, when the product is returned, prepaid, with proof of purchase. Alteration to, misuse of, or improper installation of this product voids the warranty. CURT Manufacturing LLC.'s liability is limited to repair or replacement of products found to be defective, and specifically excludes liability for incidental or consequential loss or damage. For more information log onto [www.curtmfg.com](http://www.curtmfg.com), & for helpful towing tips log onto [www.hitchinfo.com](http://www.hitchinfo.com)

# INSTALLATION WALKTHROUGH:

Parts List			
ITEM	QTY	PART NUMBER	DESCRIPTION
1	4	CM-SP10	.250 x 1.00 x 2.50" SQUARE HOLE SPACER
2	4	7/16-14 x 1 1/2	CARRIAGE BOLT
3	4	7_16 FISHWIRE	7/16" FISHWIRE
4	4	7/16-14	HEX FLANGE NUT

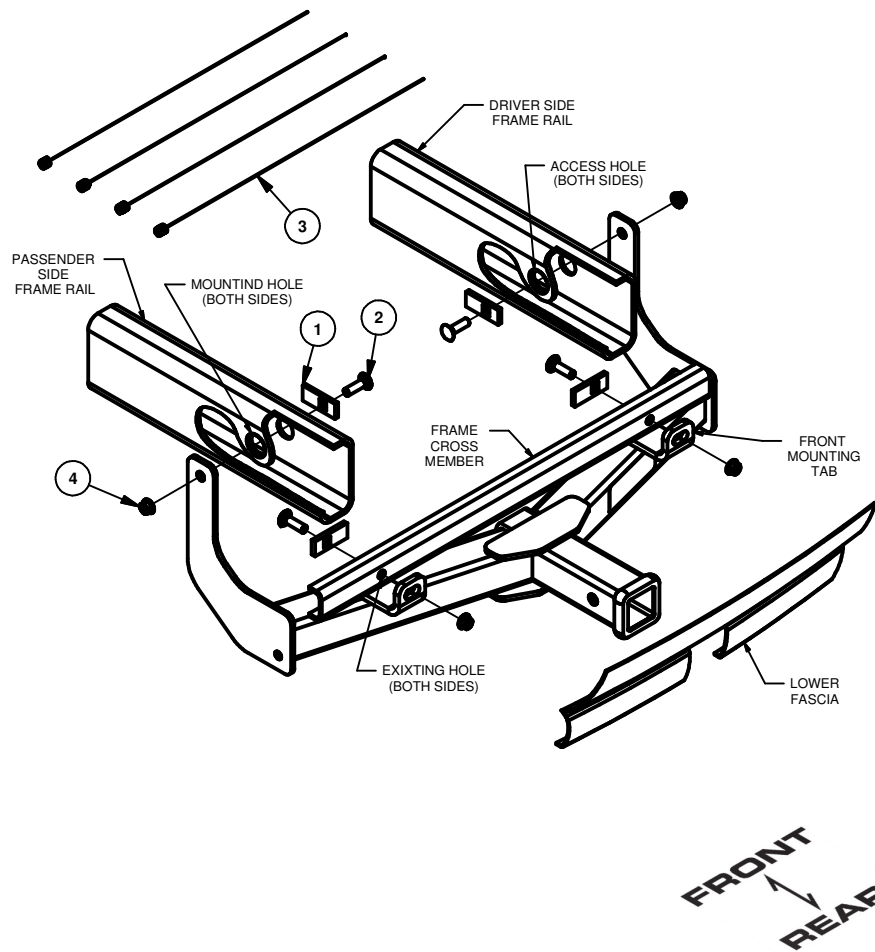

1) Determine if trimming is required on vehicle by raising hitch into position. If needed, mark and trim lower fascia, as shown above, or remove lower fascia and return to owner. **Note:** Check for proper fit prior to trimming.

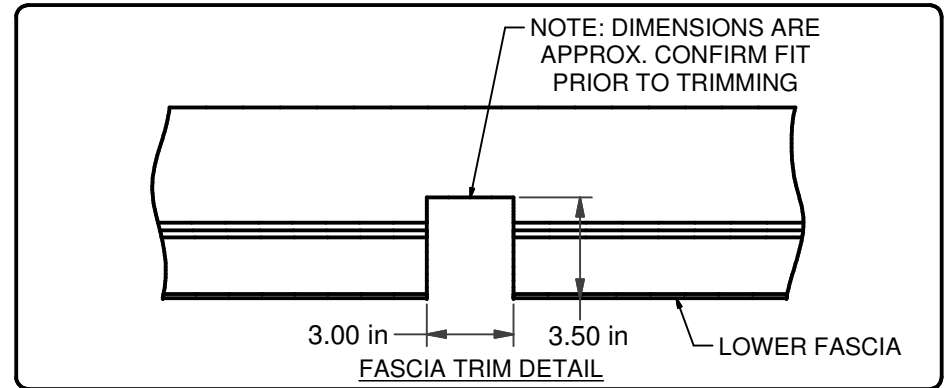

2) Remove skid plate. OPTIONAL-Trim 1/2" from edge and replace later (SEE SKID PLATE TRIM DETAIL)

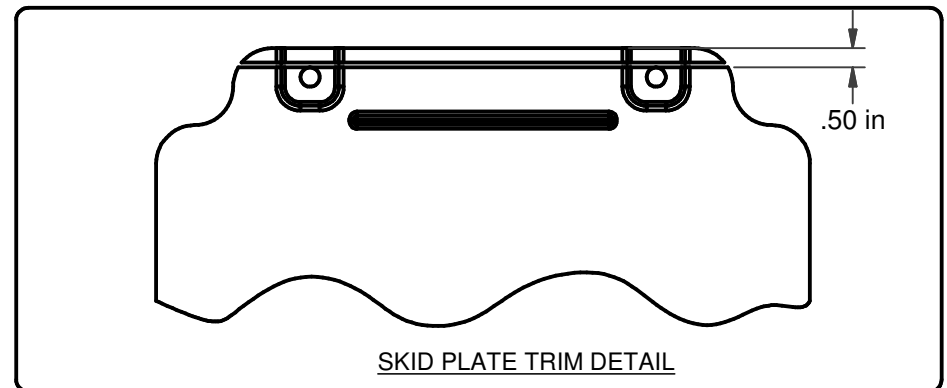

## INSTALLATION WALKTHROUGH:

3) Raise hitch into position aligning the mounting holes with the upper holes in hitch on both sides.

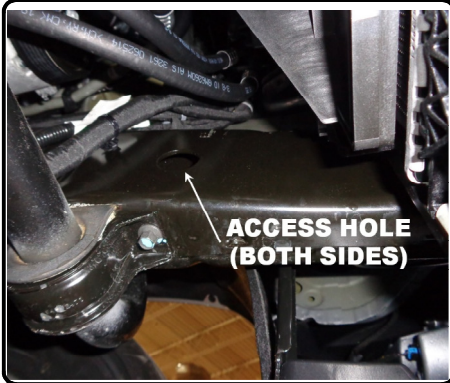

4) Fishwire (2) 7/16" carriage bolts and SP2 spacers into position through the access holes as shown.

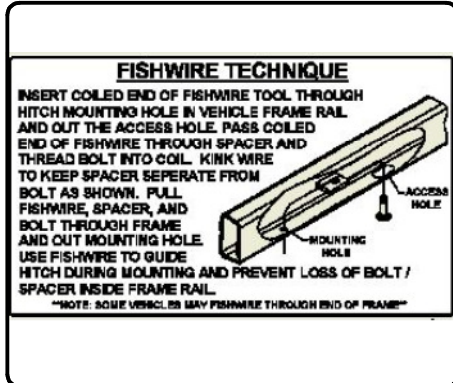
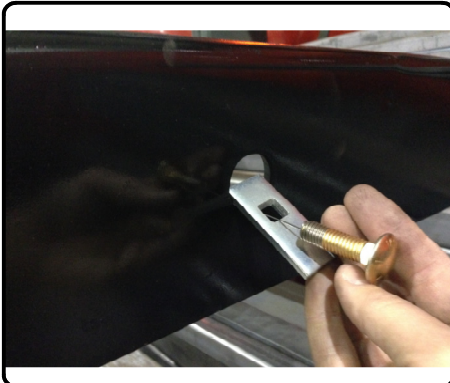

5) Loosely install nuts, being careful not to push bolt into the frame.



6) Rotate the hitch into position aligning holes in the frame cross member with the slots in the front mounting tabs.

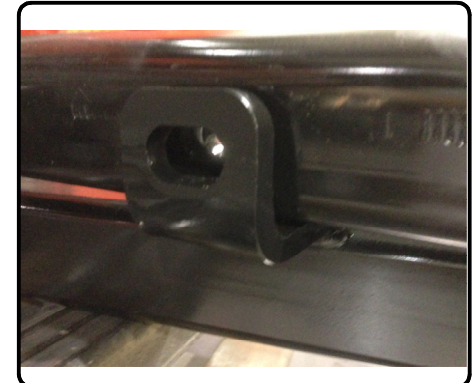
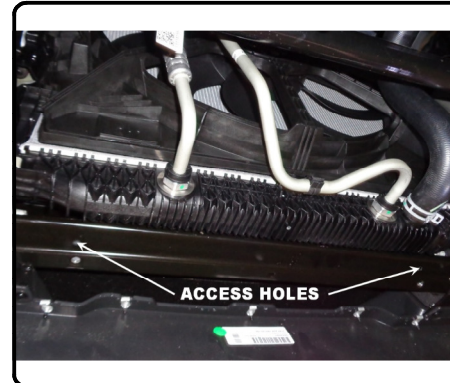

## INSTALLATION WALKTHROUGH:

7) Install remaining (2) 7/16" carriage bolts and SP2 spacers in each hole. Loosely install nuts.

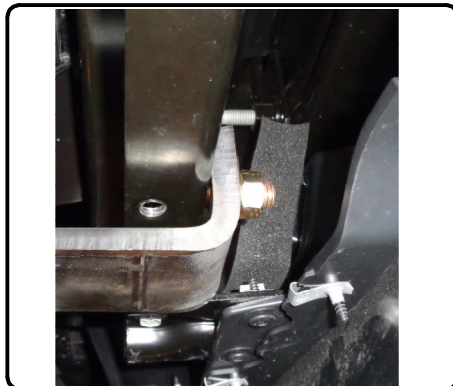

8) Ensure the hitch is aligned to the trimmed lower fascia. Adjust as needed.

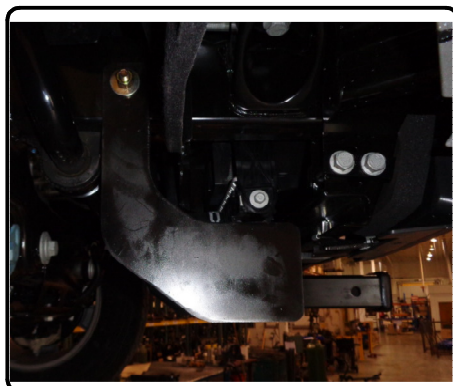
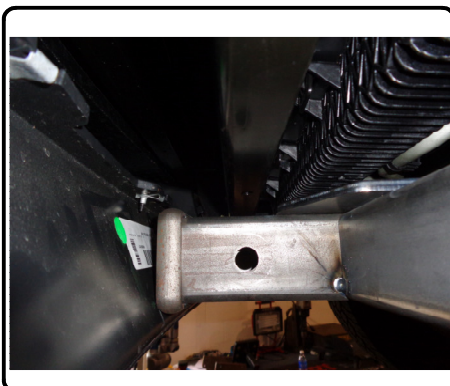

9) Torque all 7/16" fasteners to 69 ft-lbs.

OPTIONAL-Replace trimmed skid plate.

Installation complete.

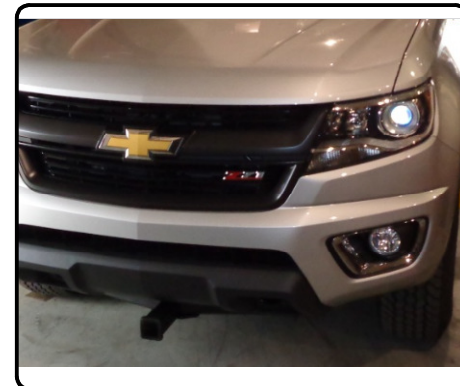
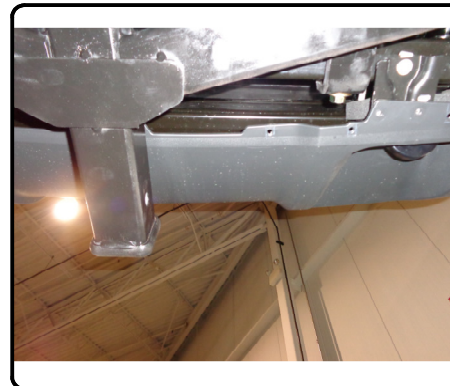

# 31074

# CHEVROLET COLORADO & CANYON

12/19/2014

GROSS LOAD CAPACITY WHEN USED AS A WEIGHT CARRYING HITCH: 5,000 LBS. TRAILER WEIGHT & 500 LBS. TONGUE WEIGHT.

GROSS LOAD CAPACITY WHEN USED AS A STRAIGHT LINE PULL: 9,000 LBS. MAX. LINE PULL.

**\*\*\* DO NOT EXCEED VEHICLE MANUFACTURER'S RECOMMENDED TOWING CAPACITY. \*\*\***

HAVING INSTALLATION QUESTIONS? CALL TECHNICAL SUPPORT AT 1-800-798-0813

Parts List			
ITEM	QTY	PART NUMBER	DESCRIPTION
1	4	CM-SP10	.250 x 1.00 x 2.50" SQUARE HOLE SPACER
2	4	7/16-14 x 1 1/2	CARRIAGE BOLT
3	4	7_16 FISHWIRE	7/16" FISHWIRE
4	4	7/16-14	HEX FLANGE NUT

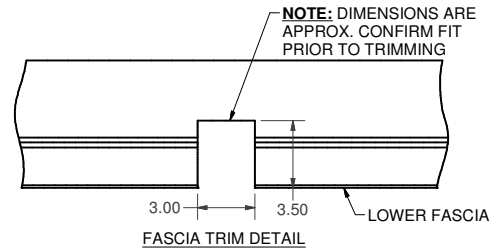

**FISHWIRE TECHNIQUE**

INSERT COILED END OF FISHWIRE TOOL THROUGH HITCH MOUNTING HOLE IN VEHICLE FRAME RAIL AND OUT THE ACCESS HOLE. PASS COILED END OF FISHWIRE THROUGH SPACER AND THREAD BOLT INTO COIL. KINK WIRE TO KEEP SPACER SEPERATE FROM BOLT AS SHOWN. PULL FISHWIRE, SPACER, AND BOLT THROUGH FRAME AND OUT MOUNTING HOLE. USE FISHWIRE TO GUIDE HITCH DURING MOUNTING AND PREVENT LOSS OF BOLT / SPACER INSIDE FRAME RAIL.

\*NOTE: SOME VEHICLES MAY FISHWIRE THROUGH END OF FRAME\*

**TOOLS REQUIRED**

RATCHET
TORQUE WRENCH
AVIATION SHEARS
11/16" SOCKET
15mm SOCKET
10mm SOCKET
11/16" OPEN END WRENCH

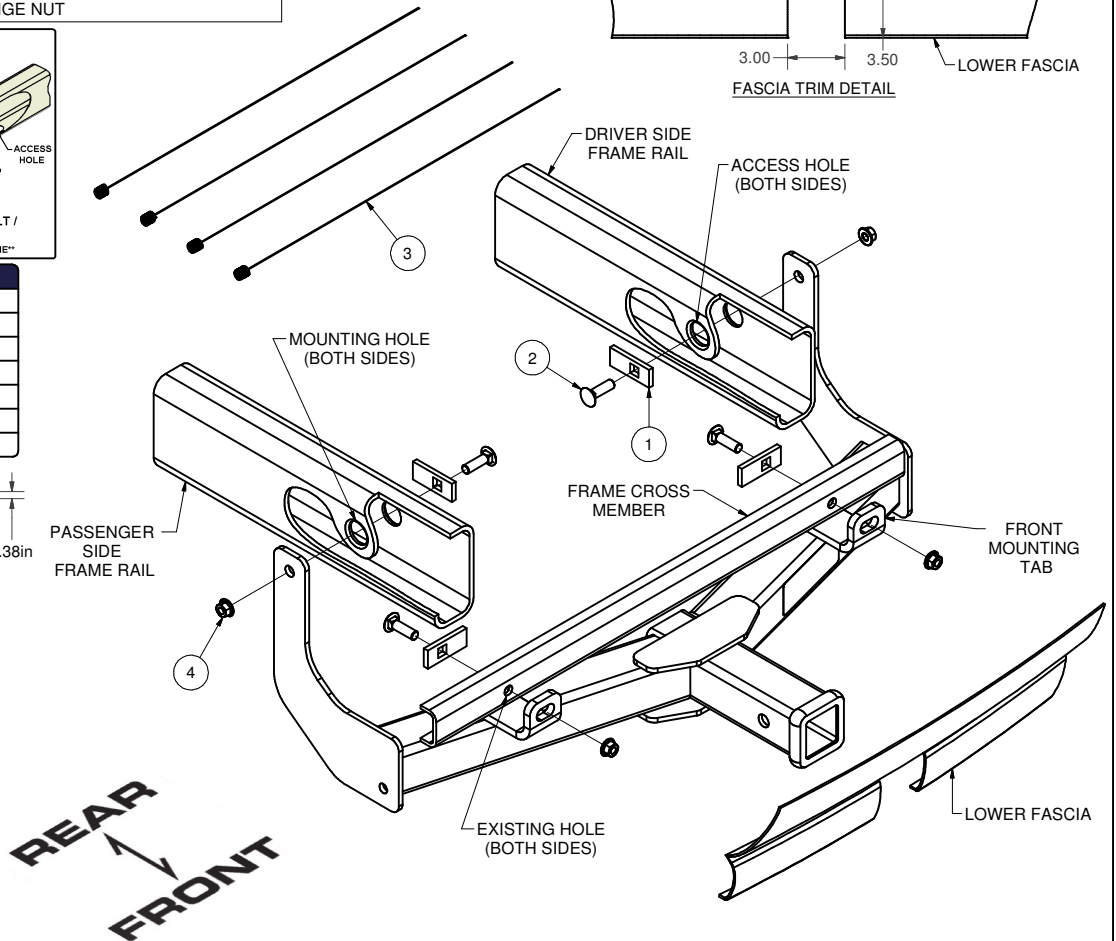
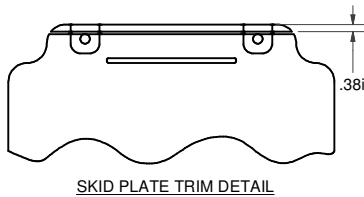

HITCH WEIGHT: 35 LBS.

**INSTALL TIME**

PROFESSIONAL: 45 MINUTES

NOVICE (DIY): 90 MINUTES

**INSTALL NOTES:**

- NO DRILLING REQUIRED
- MAY REQUIRE FASCIA TRIMMING OR REMOVAL

### INSTALLATION STEPS

- 1) Determine if trimming is required on vehicle by raising hitch into position. If needed, mark and trim lower fascia, as shown above, or remove lower fascia and return to owner. **Note:** Check for proper fit prior to trimming.
- 2) Remove skid plate. OPTIONAL-Trim 1/2" from edge and replace later (SEE SKID PLATE TRIM DETAIL)
- 3) Raise hitch into position aligning the mounting holes with the upper holes in hitch on both sides.
- 4) Fishwire (2) 7/16" carriage bolts and SP2 spacers into position through the access holes as shown.
- 5) Loosely install nuts, being careful not to push bolt into the frame.
- 6) Rotate the hitch into position aligning holes in the frame cross member with the slots in the front mounting tabs.
- 7) Install remaining (2) 7/16" carriage bolts and SP2 spacers in each hole. Loosely install nuts.
- 8) Ensure the hitch is aligned to the trimmed lower fascia. Adjust as needed.
- 9) Torque all 7/16" fasteners to 69 ft-lbs. OPTIONAL-Replace trimmed skid plate. Installation complete.



Scan for more information

**PERIODICALLY CHECK THIS RECEIVER HITCH TO ENSURE THAT ALL FASTENERS ARE TIGHT AND THAT ALL STRUCTURAL COMPONENTS ARE SOUND.**

CURT Manufacturing LLC., warrants this product to be free of defects in material and/or workmanship at the time of retail purchase by the original purchaser. If the product is found to be defective, CURT Manufacturing LLC., may repair or replace the product, at their option, when the product is returned, prepaid, with proof of purchase. Alteration to, misuse of, or improper installation of this product voids the warranty. CURT Manufacturing LLC.'s liability is limited to repair or replacement of products found to be defective, and specifically excludes liability for incidental or consequential loss or damage.

\*\*\*DO NOT EXCEED VEHICLE MANUFACTURER'S RECOMMENDED TOWING CAPACITY\*\*\*.

### FRONT MOUNTED ACCESSORIES

1) Do not exceed front axle Gross Weight Rating (GAWR). Consult owners manual or specification plate located on driver's door frame. Measure gross front axle weight by placing front wheels of loaded vehicle on a scale.

**WARNING:** Exceeding GAWR may overload the front axle and/or suspension. This could result in **accident, property damage and personal injury.**

- 2) Reposition front mounted license plate if obstructed.
- 3) Do not obstruct vehicle lights.
- 4) Allow free air flow into grille opening.
- 5) Rear wheel traction may be reduced. This could effect handling. Reduce speed and drive with caution.
- 6) Accessories extend front of vehicle. This may reduce approach angle. Use caution when parking and maneuvering.
- 7) Do not obstruct driver view.

### VEHICLE RECOVERY AND WINCHING TIPS

1) Use OEM tow hooks, recovery eyes or a clevis mount for attachment of a tow strap or winch cable.

**WARNING: NEVER** use a ball and/or ball mount as an anchor point for tow strap or winch cable. Severe personal injury or death could result.

- 2) Observe winch manufacturer's recommendations, cautions and warnings.
- 3) Attach return cable to tow hook or recovery eye when using a snatch block (See figure 1).

**CAUTION:** Do not attach return cable to winch mount. This may overload winch mount and/or front mounted receiver.

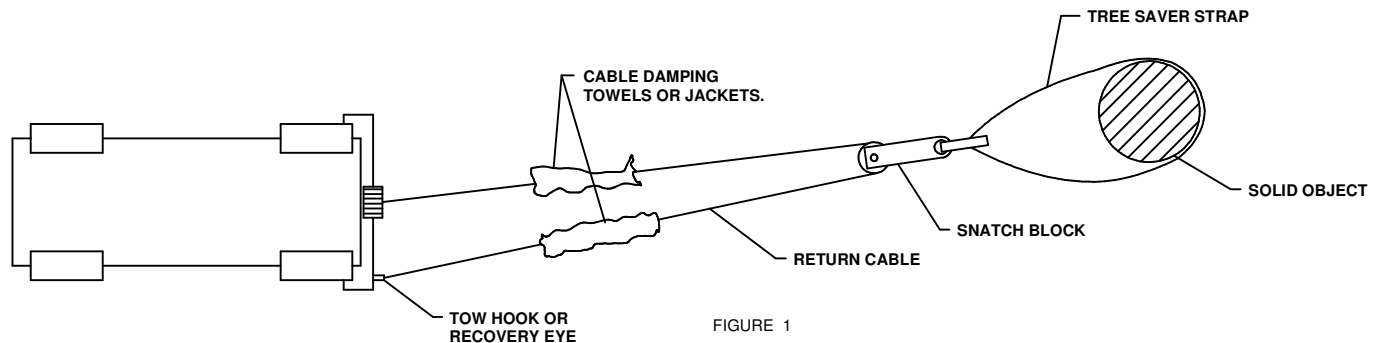

### RATING

For **Maximum** line pull rating, winch cable must not exceed:

- 15 degree angle up or down from horizontal (See Figure 2).
- 45 degree angle left or right from straight ahead (See Figure 3).

**CAUTION:** Exceeding the maximum line pull rating may over load winch, winch mount, and/or front mounted receiver.

