



# 31032 INSTALLATION INSTRUCTIONS



Safety glasses should be worn at all times while installing this product.

YEARS: 2010-CURRENT

MAKE: CHEVROLET & GMC

MODEL: EQUINOX & TERRAIN

STYLE: CROSSOVER

**WARNING: NEVER EXCEED YOUR VEHICLE MANUFACTURER'S RECOMMENDED TOWING CAPACITY**

**WEIGHT CARRYING:**  
TRAILER WEIGHT: 3,500 LBS.  
TONGUE WEIGHT: 350 LBS.

**GROSS LOAD CAPACITY WHEN USED AS A STRAIGHT LINE PULL:**  
9,000 LBS MAX.

**INSTALLATION TIME: 45 MIN.**

THE INSTALL TIME LISTED IS FOR PROFESSIONAL INSTALLERS. IF YOU ARE HESITANT TO UNDERTAKE THIS TASK ON YOUR OWN, CONTACT AN AUTHORIZED CURT INSTALLER FOR ADDITIONAL ASSISTANCE.

**INSTALLATION REQUIRES:**

 <b>RATCHET</b>	 <b>TORQUE WRENCH</b>	 <b>3/4" 11/16" SOCKET</b>
 <b>10" SOCKET EXTENSION</b>	 <b>UTILITY KNIFE</b>	 <b>TAPE MEASURE</b>
 <b>POWER DRILL</b>	 <b>DRILL BIT 17/32"</b>	 <b>DIE GRINDER</b>

**INSTALLATION TIPS:**

- BEFORE YOU BEGIN INSTALLATION, READ ALL INSTRUCTIONS THOROUGHLY.
- TO EASE INSTALLATION, 2 PEOPLE MAY BE REQUIRED.
- USING PROPER TOOLS WILL GREATLY IMPROVE THE QUALITY OF THE INSTALL AND REDUCE THE TIME REQUIRED.
- NEED HELP OR HAVE SOME QUESTIONS? CALL TECHNICAL SUPPORT AT 800.798.0813

**LEVEL OF DIFFICULTY: MODERATE**

EASY	MODERATE	HARD
 <b>TRIM</b>	- FASCIA TRIMMING REQUIRED	
	- DRILLING REQUIRED	
	- FISHWIRE HARDWARE	

**VEHICLE PHOTO:**



REPRESENTATIVE PHOTO

**HITCH ILLUSTRATION:**

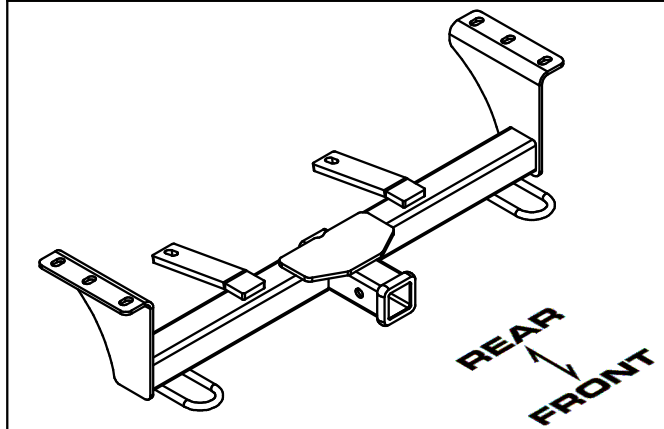

MAKE SURE YOUR HITCH MATCHES

**PERIODICALLY CHECK THIS RECEIVER HITCH TO ENSURE ALL FASTENERS ARE TIGHT AND ALL STRUCTURAL COMPONENTS ARE SOUND**

CURT Manufacturing Inc. warrants this product to be free of defects in material and/or workmanship at the time of retail purchase by the original purchaser. If the product is found to be defective, Curt Manufacturing Inc. may repair or replace the product at their option, when the product is returned, prepaid, with proof of purchase. Alteration to, misuse of, or improper installation of this product voids the warranty. Curt Manufacturing Inc.'s liability is limited to repair or replacement of products found to be defective, and specifically excludes liability for incidental or consequential loss or damage.

For more information log onto [www.curtmfg.com](http://www.curtmfg.com), & for helpful towing tips log onto [www.hitchinfo.com](http://www.hitchinfo.com)

## INSTALLATION WALKTHROUGH:

Parts List			
ITEM	QTY	PART NUMBER	DESCRIPTION
1	2	1_2 FISHWIRE	1/2" FISHWIRE
2	2	7_16 FISHWIRE	7/16" FISHWIRE
3	6	CM-SP6	.250 x 1.00 x 3.00" SQUARE HOLE SPACER
4	2	CM-SP7	.250 x 1.00 x 2.00" SQUARE HOLE SPACER
5	6	1/2-13 x 1 1/2	CARRIAGE BOLT
6	6	HFN 1213	HEX FLANGE NUT
7	2	7/16-14 x 1 1/2	CARRIAGE BOLT
8	2	7/16-14	HEX FLANGE NUT

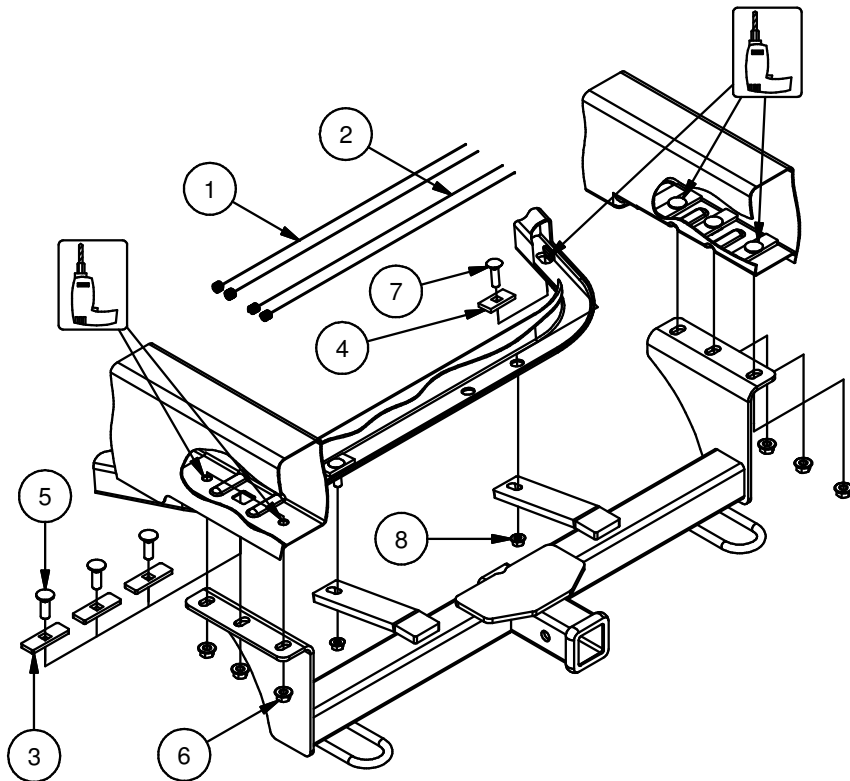

### 1. Mark and trim front fascia.

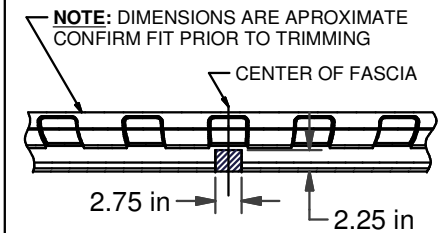

- ### 2. Raise hitch into position and mark drill hole locations in the frame rails. Lower hitch and drill marked holes. Enlarge the existing front most holes to allow a 1/2" carriage bolt to pass through. **Note:** When marking and drilling holes confirm that all existing holes are aligned.



## INSTALLATION WALKTHROUGH:

3. Fishwire 1/2-13 x 1 1/2" carriage bolts and SP6 spacers through the access hole and out the front and rear holes in frame rails.

**FISHWIRE TECHNIQUE**  
INSERT COILED END OF FISHWIRE TOOL THROUGH HITCH MOUNTING HOLE IN VEHICLE FRAME RAIL AND OUT THE ACCESS HOLE. PASS COILED END OF FISHWIRE THROUGH SPACER AND THREAD BOLT INTO COIL. KINK WIRE TO KEEP SPACER SEPERATE FROM BOLT AS SHOWN. PULL FISHWIRE, SPACER, AND BOLT THROUGH FRAME AND OUT MOUNTING HOLE. USE FISHWIRE TO GUIDE HITCH DURING MOUNTING AND PREVENT LOSS OF BOLT / SPACER INSIDE FRAME RAIL.

\*\*NOTE: SOME VEHICLES MAY FISHWIRE THROUGH END OF FRAME\*\*

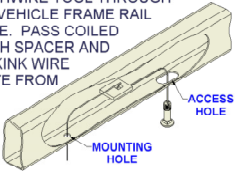

4. Reverse fishwire 1/2-13 x 1 1/2" carriage bolts and SP6 spacers into the access holes.

### REVERSE PULL FISHWIRE TECHNIQUE

ATTACH FISHWIRE TO CARRIAGE BOLT AND SLIDE SPACER ONTO FISHWIRE. PUSH THE BOLT THRU THE HOLE FOLLOWED BY THE SPACER (AS SHOWN). PULL BOLT BACK INTO POSITION, PROTRUDING FROM THE FRAME.

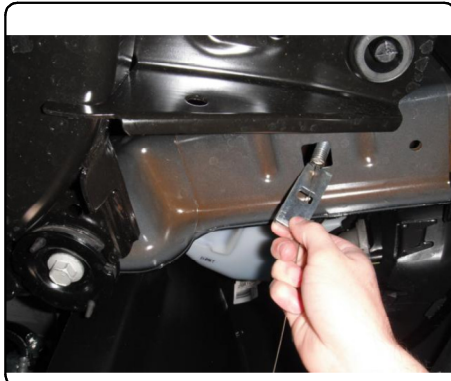
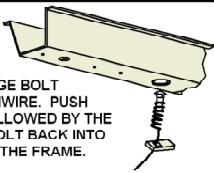

5. Enlarge the access holes in the cross member to allow 7/16-14 x 1 1/2" carriage bolts and SP7 spacers to pass through. Raise the hitch into position and loosely secure the side plates with 1/2" flange nuts.



6. Fishwire 7/16-14 x 1 1/2" carriage bolts and SP7 spacers through the enlarged cross member access holes and out the holes in the mounting straps. Secure the mounting straps with 7/16" flange nuts.



## INSTALLATION WALKTHROUGH:

7. Torque all 1/2" hardware to 110 ft-lbs.  
Torque all 7/16" hardware to 70 ft-lbs.



Hitch installation is complete.

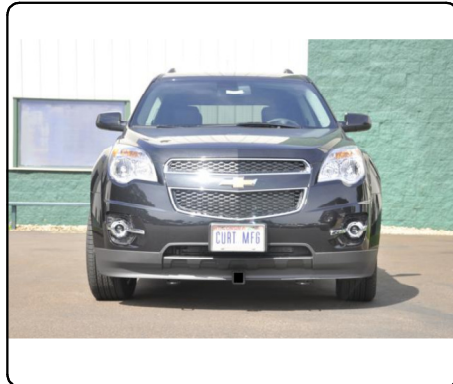

31032

# CHEVROLET EQUINOX & GMC TERRAIN

12/10/2012

GROSS LOAD CAPACITY WHEN USED AS A WEIGHT CARRYING HITCH: 3,500 LBS. TRAILER WEIGHT & 350 LBS. TONGUE WEIGHT.

GROSS LOAD CAPACITY WHEN USED AS A STRAIGHT LINE PULL: 9,000 LBS. MAX. LINE PULL.

**\*\*\* DO NOT EXCEED VEHICLE MANUFACTURER'S RECOMMENDED TOWING CAPACITY. \*\*\***

HAVING INSTALLATION QUESTIONS? CALL TECHNICAL SUPPORT AT 1-800-798-0813

Parts List			
ITEM	QTY	PART NUMBER	DESCRIPTION
1	6	HFN 1213	HEX FLANGE NUT
2	6	CM-SP6	.250 x 1.00 x 3.00" SQUARE HOLE SPACER
3	6	1/2-13 x 1 1/2	CARRIAGE BOLT
4	2	1_2 FISHWIRE	1/2" FISHWIRE
5	2	7_16 FISHWIRE	7/16" FISHWIRE
6	2	CM-SP7	.250 x 1.00 x 2.00" SQUARE HOLE SPACER
7	2	7/16-14 x 1 1/2	CARRIAGE BOLT
8	2	7/16-14	HEX FLANGE NUT

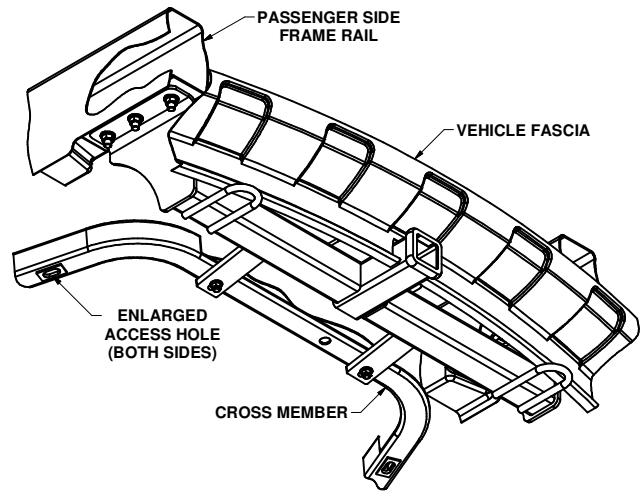

HITCH SHOWN INSTALLED

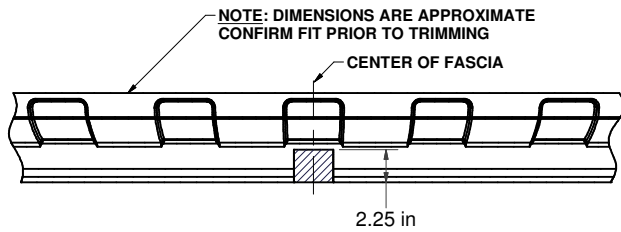

FASCIA TRIM DIAGRAM

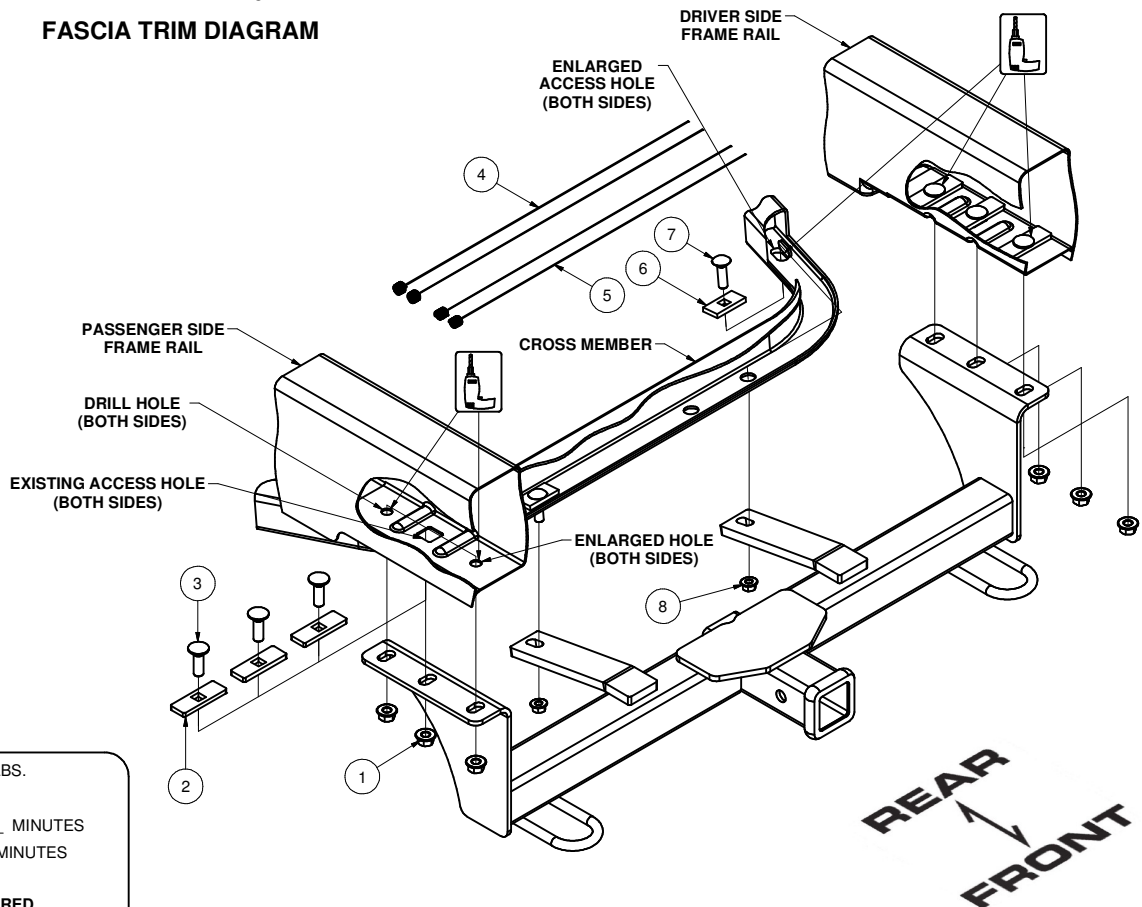

HITCH WEIGHT: 41 LBS.

INSTALL TIME

PROFESSIONAL: 45 MINUTES

NOVICE (DIY): 90 MINUTES

INSTALL NOTES:

- DRILLING REQUIRED
- FISHWIRE HARDWARE
- FASCIA TRIMMING REQUIRED

**PERIODICALLY CHECK THIS RECEIVER HITCH TO ENSURE THAT ALL FASTENERS ARE TIGHT AND THAT ALL STRUCTURAL COMPONENTS ARE SOUND.**

Curt Manufacturing Inc., warrants this product to be free of defects in material and/or workmanship at the time of retail purchase by the original purchaser. If the product is found to be defective, Curt Manufacturing Inc., may repair or replace the product, at their option, when the product is returned, prepaid, with proof of purchase. Alteration to, misuse of, or improper installation of this product voids the warranty. Curt Manufacturing Inc.'s liability is limited to repair or replacement of products found to be defective, and specifically excludes liability for incidental or consequential loss or damage.

**31032****CHEVROLET EQUINOX & GMC TERRAIN**

GROSS LOAD CAPACITY WHEN USED AS A WEIGHT CARRYING HITCH: 3,500 LBS. TRAILER WEIGHT &amp; 350 LBS. TONGUE WEIGHT.

GROSS LOAD CAPACITY WHEN USED AS A STRAIGHT LINE PULL: 9,000 LBS. MAX. LINE PULL.

**\*\*\* DO NOT EXCEED VEHICLE MANUFACTURER'S RECOMMENDED TOWING CAPACITY. \*\*\***

HAVING INSTALLATION QUESTIONS? CALL TECHNICAL SUPPORT AT 1-800-798-0813

**TOOLS REQUIRED**

RATCHET

TORQUE WRENCH

3/4" SOCKET

1 1/16" SOCKET

10" EXTENSION

UTILITY KNIFE

TAPE MEASURE

DRILL

17/32" DRILL BIT

DIE GRINDER

**FISHWIRE TECHNIQUE**

INSERT COILED END OF FISHWIRE TOOL THROUGH HITCH MOUNTING HOLE IN VEHICLE FRAME RAIL AND OUT THE ACCESS HOLE. PASS COILED END OF FISHWIRE THROUGH SPACER AND THREAD BOLT INTO COIL. KINK WIRE TO KEEP SPACER SEPERATE FROM BOLT AS SHOWN. PULL FISHWIRE, SPACER, AND BOLT THROUGH FRAME AND OUT MOUNTING HOLE. USE FISHWIRE TO GUIDE HITCH DURING MOUNTING AND PREVENT LOSS OF BOLT / SPACER INSIDE FRAME RAIL.

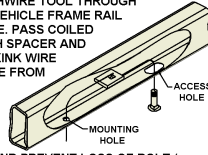

\*\*NOTE: SOME VEHICLES MAY FISHWIRE THROUGH END OF FRAME\*\*

**REVERSE PULL FISHWIRE TECHNIQUE**

ATTACH FISHWIRE TO CARRIAGE BOLT AND SLIDE SPACER ONTO FISHWIRE. PUSH THE BOLT THRU THE HOLE FOLLOWED BY THE SPACER (AS SHOWN). PULL BOLT BACK INTO POSITION, PROTRUDING FROM THE FRAME.

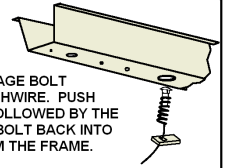
**INSTALLATION STEPS**

1. Mark and trim front fascia. (See fascia trim diagram)
2. Raise hitch into position and mark drill hole locations in the frame rails.
3. Drill the holes marked in Step (2) and enlarge the front most holes to allow a 1/2" carriage bolt pass through. **Note:** When marking and drilling holes confirm that all existing holes are aligned.
4. Fishwire 1/2-13 x 1 1/2" carriage bolts and SP6 spacers through the access hole and out the front and rear hole in the frame rails. (See fishwire technique)
5. Reverse fishwire 1/2-13 x 1 1/2" carriage bolts and SP6 spacers into the access holes. (See Reverse Fishwire technique)
6. Enlarge the access holes in the cross member to allow 7/16-14 x 1 1/2" carriage bolts and SP7 spacers to pass through.
7. Raise the hitch into position and secure the side plates with 1/2" flange nuts.
8. Fishwire 7/16-14 x 1 1/2" carriage bolts and SP7 spacers through the enlarged cross member access holes and out the holes in the mounting straps.
9. Secure the mounting straps with 7/16" flange nuts.
10. Torque all 1/2" hardware to 110 ft-lbs.  
Torque all 7/16" hardware to 70 ft-lbs.

**PERIODICALLY CHECK THIS RECEIVER HITCH TO ENSURE THAT ALL FASTENERS ARE TIGHT AND THAT ALL STRUCTURAL COMPONENTS ARE SOUND.**

Curt Manufacturing Inc., warrants this product to be free of defects in material and/or workmanship at the time of retail purchase by the original purchaser. If the product is found to be defective, Curt Manufacturing Inc., may repair or replace the product, at their option, when the product is returned, prepaid, with proof of purchase. Alteration to, misuse of, or improper installation of this product voids the warranty. Curt Manufacturing Inc.'s liability is limited to repair or replacement of products found to be defective, and specifically excludes liability for incidental or consequential loss or damage.

# CHEVROLET EQUINOX & GMC TERRAIN

\*\*\***DO NOT EXCEED VEHICLE MANUFACTURER'S RECOMMENDED TOWING CAPACITY**\*\*\*.

## FRONT MOUNTED ACCESSORIES

1) Do not exceed front axle Gross Weight Rating (GAWR). Consult owners manual or specification plate located on driver's door frame. Measure gross front axle weight by placing front wheels of loaded vehicle on a scale.

**WARNING:** Exceeding GAWR may overload the front axle and/or suspension. This could result in **accident, property damage and personal injury.**

- 2) Reposition front mounted license plate if obstructed.
- 3) Do not obstruct vehicle lights.
- 4) Allow free air flow into grille opening.
- 5) Rear wheel traction may be reduced. This could effect handling. Reduce speed and drive with caution.
- 6) Accessories extend front of vehicle. This may reduce approach angle. Use caution when parking and maneuvering.
- 7) Do not obstruct driver view.

## VEHICLE RECOVERY AND WINCHING TIPS

1) Use OEM tow hooks, recovery eyes or a clevis mount for attachment of a tow strap or winch cable.

**WARNING: NEVER** use a ball and/or ball mount as an anchor point for tow strap or winch cable. Severe personal injury or death could result.

- 2) Observe winch manufacturer's recommendations, cautions and warnings.
- 3) Attach return cable to tow hook or recovery eye when using a snatch block (See figure 1).

**CAUTION:** Do not attach return cable to winch mount. This may overload winch mount and/or front mounted receiver.

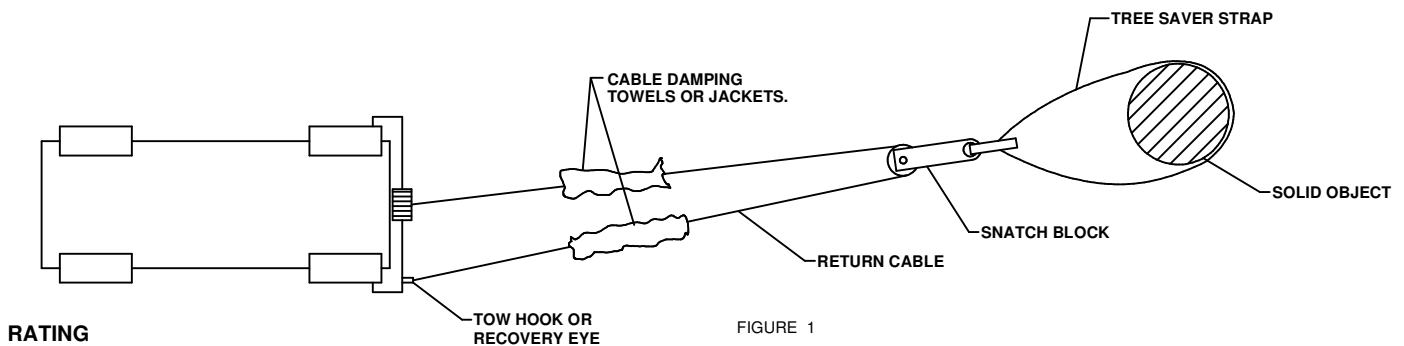

For **Maximum** line pull rating, winch cable must not exceed:  
- 15 degree angle up or down from horizontal (See Figure 2).  
- 45 degree angle left or right from straight ahead (See Figure 3).

**CAUTION:** Exceeding the maximum line pull rating may over load winch, winch mount, and/or front mounted receiver.

