



E-1 / E-2 (shown)

STEP BUMPER HITCH

GROSS LOAD CAPACITY WHEN USED AS A WEIGHT CARRYING HITCH: 5000 LBS. TRAILER WEIGHT & 500 LBS. TONGUE WEIGHT.
DO NOT EXCEED VEHICLE MANUFACTURER'S RECOMMENDED TOWING CAPACITY.

| Parts List | | | |
|------------|-----|-----------------------|---------------------------------------|
| ITEM | QTY | PART NUMBER | DESCRIPTION |
| 1 | 2 | 3/4 - 10 x 3 HEX | HEX HEAD BOLT-NC |
| 2 | 2 | 3/4-10 | HEX FLANGE NUT |
| 3 | 2 | 3/4 - 10 PLAIN WASHER | .750 STANDARD WASHER |
| 4 | 2 | CM-SP41 | .188 x 1.38 x 1.50" ROUND HOLE SPACER |

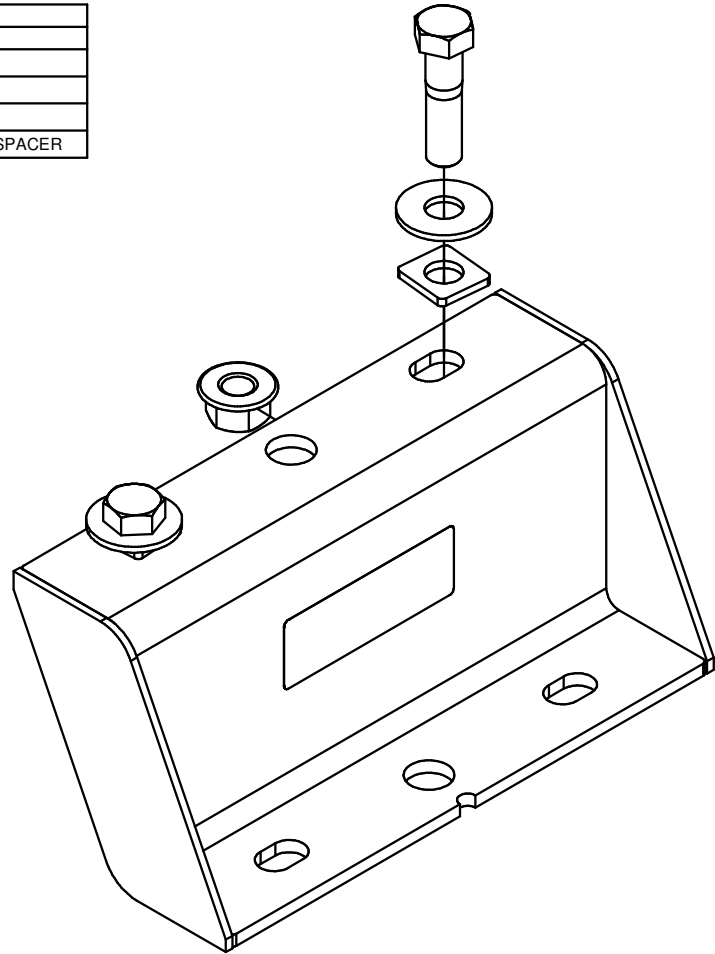

HITCH WEIGHT: 30 LBS.

INSTALL TIME: 15 MINUTES

INSTALL NOTES: **NO DRILL**

INSTALLATION STEPS

Position the step bumper hitch to the underside of the original vehicle step plate. If existing holes cannot be used, mark and drill two holes for the 3/4" hex bolts. Attach the hitch using the 3/4" hardware provided. Use the spacers provided to add clearance if welded tabs are present on the underside of your bumper.

Torque the 3/4" fasteners to 350 lb.-ft.

PERIODICALLY CHECK THIS RECEIVER HITCH TO INSURE THAT ALL FASTENERS ARE TIGHT AND THAT ALL STRUCTURAL COMPONENTS ARE SOUND.

Curt Manufacturing Inc., warrants this product to be free of defects in material and/or workmanship at the time of retail purchase by the original purchaser. If the product is found to be defective, Curt Manufacturing Inc., may repair or replace the product, at their option, when the product is returned, prepaid, with proof of purchase. Alteration to, misuse of, or improper installation of this product voids the warranty. Curt Manufacturing Inc.'s liability is limited to repair or replacement of products found to be defective, and specifically excludes liability for incidental or consequential loss or damage.