

Raptor Series



Your satisfaction is important to us, please let us help!

If you have any questions or concerns during the installation, our support representatives are available to assist you.

Please call: 1-877-769-3765 or Live Chat at www.raptorseries.com

If you have damaged or missing parts please contact the company you purchased the product from and notify them of the issue right away.



CAUTION: Do not install damaged parts!!!

Raptor Series

Easy Return / Easy Exchange

Want to return an item or exchange? Not satisfied with purchase?

No problem. We strongly believe in service after the sale and we stand behind our products and our service to you, our valued customer. There is no problem we can't solve for you!

Items that have been installed and/or damaged after receipt, are no longer in new and ready-to-sell condition and cannot be refunded, replaced or exchanged unless it has a manufacturer defect or was damaged in shipping. In addition, we cannot accept return on items that are not in the original packaging. Items returned in poor condition or having parts missing will not be credited.

Please note: Your request for return or replacement must be initiated within 30 days of delivery of your merchandise.

Did your order arrive damaged?

Please do not install damaged products. Contact the company you purchased your product from as soon as possible and notify them of the damages. They will make arrangements with you to assist with the problem.

Did you order the wrong part or receive the wrong item?

Don't worry. From time to time human error can result in problems with ordering or shipping. Contact the company you purchased your product from as soon as you notice the error. Every company has their own policy on returning parts that have been ordered incorrectly or shipped incorrectly.

In the event that you need to ship your part back to return/exchange, please ship to the warehouse below:

**CYC Returns Warehouse
2415 Cathy Lane
Jasper, IN 47546**

The logo for the Raptor Series, featuring the word "Raptor" in a green, cursive font and "Series" in a black, bold, sans-serif font below it. The background of the logo is a faint, light green silhouette of a raptor in flight.

Raptor Series

Raptor Series Warranty

LIMITED TEN (10) YEAR WARRANTY

For Powder Coated Steel Products

CYC Engineering, Inc. guarantees the original purchaser of our products a limited ten (10) year warranty from the date of original purchase against manufacturer defects in materials, workmanship and finish under normal use. The step pads are covered under warranty for 1 year. This warranty does not include damage resulting from road hazards such as gravel or other debris, product misuse, improper installation, impairments from accidents, product modifications, product neglect or scratches during the life of the product. This limited ten year warranty applies only to new products and is limited to the repair or replacement of company's products. Warranty does not include costs of removal, installation, labor, inconvenience or consequential damages. Original purchaser must return defective merchandise along with the purchase receipt, to the original place of purchase.

LIMITED LIFETIME WARRANTY

For Stainless Steel Products

CYC Engineering, Inc. guarantees the original purchaser of our products a limited lifetime warranty from the date of original purchase against manufacturer defects in materials, workmanship and finish under normal use. The step pads are covered under warranty for 1 year. This warranty does not include damage resulting from road hazards such as gravel or other debris, product misuse, improper installation, impairments from accidents, product modifications, product neglect or scratches during the life of the product. This limited lifetime warranty applies only to new products and is limited to the repair or replacement of company's products. Warranty does not include costs of removal, installation, labor, inconvenience or consequential damages. Original purchaser must return defective merchandise along with the purchase receipt, to the original place of purchase.

1303-0120

RUNNING BOARD

Raptor Series

Components:

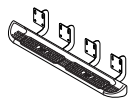

Driver Side
Running Board Assembly
Qty. 1
(Brackets already attached)

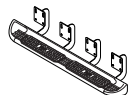

Passenger Side
Running Board Assembly
Qty. 1
(Brackets already attached)

Hardware:



M8 x 30 mm
Hex Head Bolts
Qty 24



Teflon
Washer
Qty 4



M8 Flat
Washers
Qty 24



M8 Lock
Washers
Qty 24



M8 U Nut Clip
Qty 24

Tools Required:

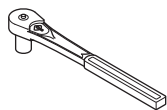

RATCHET

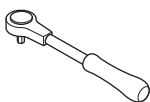
TORQUE
WRENCH

14MM SOCKET

Torque Specifications:

For Rocker Panel Installations
M8 through M12 sized bolts/nuts are set to 15-20 ft lbs.

Note: When installing the brackets and boards, all hardware must be left loose until all the items are attached.

1. Remove all contents from the package and check stainless steel running boards for any damage. Also, verify that all components and hardware listed above are included before you begin installation.
2. Read installation manual and installation drawing completely. Understand all brackets and bolts before installation.
3. Begin installation on passenger side.
4. Existing mounting holes are located on the interior wall of the rocker panel. These mounting holes will be used per the following instruction.

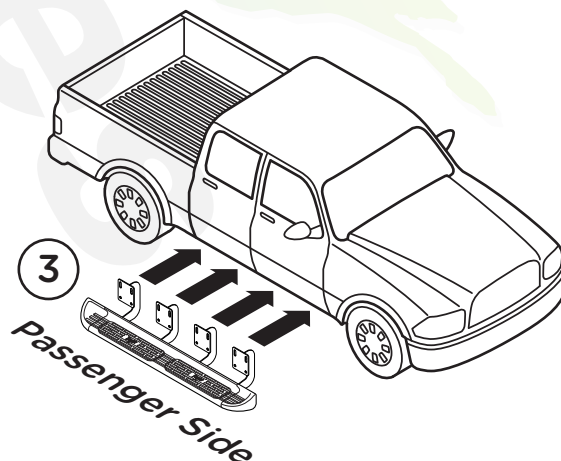

5. For the Front Brackets on the vertical wall of each rocker panel, install the three (3) U-Nuts as shown. Two (2) U Nut Clips are to be installed covering the two (2) mount holes and one (1) U Nut Clip is to be installed on the bottom of the body panel. Install these U Nut Clips so that the threads are to the inside of the rocker panel. Be careful not to drop the U Nut Clip inside of the rocker panel.

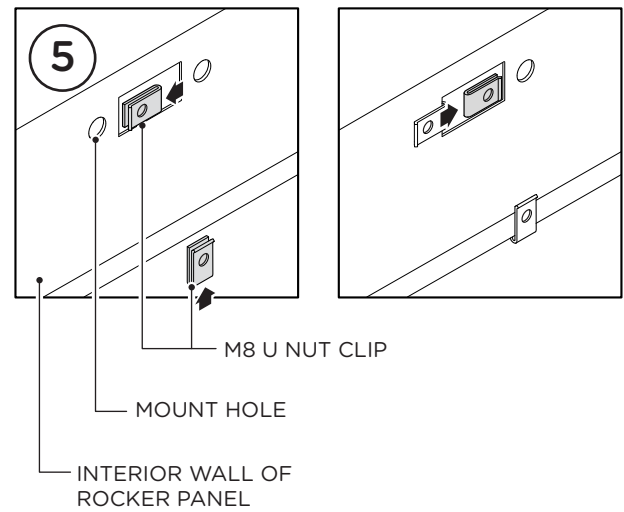

6. For the Center and Rear Brackets, on the vertical wall of each rocker panel, install the three (3) U Nut Clips as shown.

One (1) U Nut Clip is to be installed covering the one (1) mount hole toward the front of vehicle and two (2) U Nut Clips are to be installed on the bottom of the body panel. Install these U Nut Clips so that the threads are to the inside of the rocker panel. Be careful not to drop the U Nut Clip inside of the rocker panel.

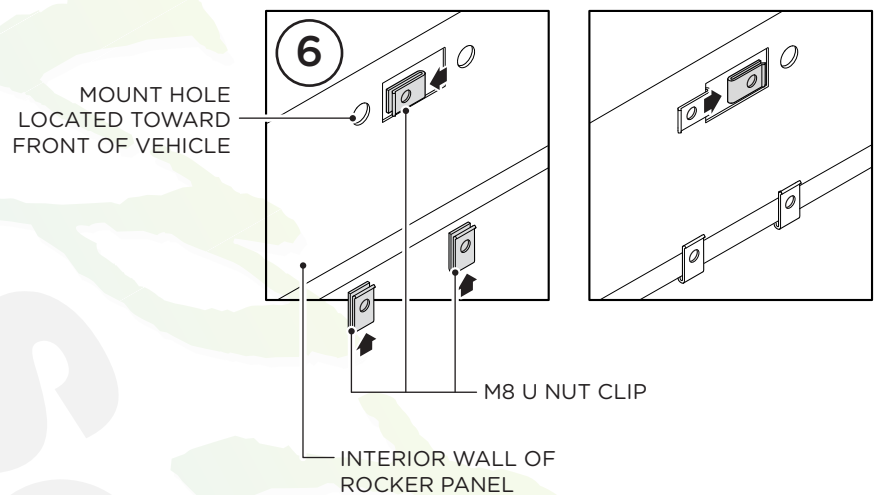

7. Install the passenger side Front Bracket by fastening two (2) M8 x 30 mm Hex Head Bolts, two (2) M8 Flat Washers, two (2) M8 Lock Washers and two (2) Teflon Washers through the top two oblong holes and into the M8 U-Nuts.

8. Complete the installation of the Front Bracket by fastening one (1) M8 x 30 mm Hex Head Bolt, one (1) M8 Flat Washer and one (1) M8 Lock Washer through the bottom hole facing to rear of vehicle and into the M8 U Nut Clips.

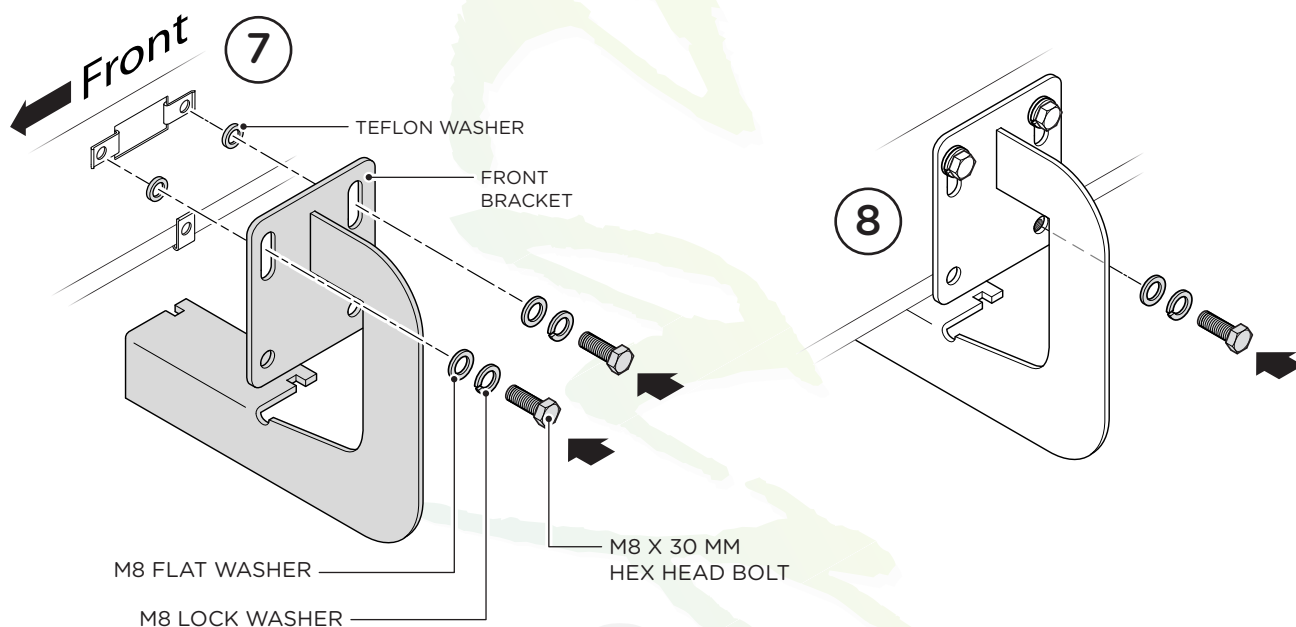

9. Install the passenger side Center and Rear Brackets by fastening one (1) M8 x 30 mm Hex Head Bolt, one (1) M8 Flat Washer and one (1) M8 Lock Washer into top oblong hole located toward the front of vehicle and into the M8 U Nut Clips.

10. Complete the installation of the Front Bracket by fastening two (2) M8 x 30 mm Hex Head Bolts, two (2) M8 Flat Washers and two (2) M8 Lock Washers through the bottom holes and into the U Nut Clips.

Repeat these steps for driver side installation. When all hardware is in place, everything must be tightened. See Page 1 for Torque Specifications.

