



## SYSTEM #17429

1994-2001 DODGE RAM TRUCK

5.2L & 5.9L V8 ENGINES · ALL WHEELBASES

12/07/09

### Removal:

- 1) Raise the vehicle up on a hoist or rack to working height. If you do not have access to a hoist or rack raise the vehicle and support securely with jack stands.
- 2) Using a hacksaw or sawsall, cut the stock tailpipe off where it exits the muffler. (This step is not mandatory, but will make removal easier.)
- 3) Separate the two rubber hangers on the tailpipe, just behind the muffler, from their rubber mounts on the vehicle. Remove the two bolts at the rear of the tailpipe that connect the stock tailpipe hanger to the frame of the vehicle. Remove the tailpipe and set aside.
- 4) Support the muffler with a stand. Remove the clamp in front of the muffler. Because this connection may be significantly crimped by the clamp it may be necessary to heat this connection for ease of removal. If this does not work use a hacksaw or sawsall to cut the muffler off right after hydrosize on inlet pipe. Take a saw and slice excess off the inlet pipe.
- 5) Remove the muffler and set aside.

### Installation:

- 1) Before installing anything, prep the clamps supplied in the hardware kit by removing the nuts, and applying a thick lubricant such as white grease or anti-seize to the threads.
- 2) Place inlet pipe **#TB230** in position on the front pipe from the catalytic converter. Install one of the 2 1/2" clamps provided and tighten enough to hold, but still allow for adjustment.
- 3) Connect the inlet of the muffler **#530552** to the inlet pipe. Use a stand to support the muffler and install a 3" clamp. Tighten enough to hold, but still allow for adjustment.
- 4) Due to the frame variations of model years, we have included two different rear tailpipe hangers for the left side of the vehicle. To determine which to use, look on drivers side of the frame, just behind the rear wheel. Look for a large slotted hole (small on the 2000 model), with a smaller 1/4" diameter hole about 1" below the large hole. If these two holes are present, use hanger **#208HA**, with a 5/16" bolt, nut and washer for the top hole and 1/4" bolt, nut and washer for the bottom hole. If these holes are not there, look on bottom edge of frame at about 18" forward of the rear bumper. There should be two holes side-by-side at about 3/4" apart. Mount hangers **#211HA** using the forward hole with a 5/16" bolt, nut and washer.

If you have an aftermarket tow hitch, such as Drawtite, etc. We have included two 5/16" shoulder bolts that will allow you to bolt rubber hanger **#HA168** directly to the side of the tow hitch. As the mounting arms of the hitch begin to narrow toward the front of the vehicle, there will be two holes located on the side of the hitch. Place **#HA168** up to the forward hole and insert the shoulder bolt with the 3/8" washer through **#HA168** from the inside of the hitch. Use the 5/16" lock washer and nut to secure the hanger into place. Repeat this step for the passenger side of the vehicle.

- 5) Take the two rubber hangers **#HA168** and slide them onto the hanger mount installed in Step 4. Then take the clamp hangers **#209HA** and slide them into the bottom of the rubber hangers. The kit diagram shows which way to insert the hangers.
- 6) Place right side tailpipe **#16127** in position over the axle and slip into the right side muffler outlet and insert the hanger into the right rubber hanger mount on the frame. Place the rear of the tailpipe into the clamp hanger. Install a clamp onto muffler outlet and tighten enough to hold, but still allow for adjustment.
- 7) Place the front section of the left side tailpipe **#16128** into the left side muffler outlet and insert hanger into the left rubber hanger mount on the frame. Install a clamp onto the muffler outlet and tighten enough to hold, but still allow for adjustment.
- 8) Connect the rear section of the left side tailpipe **#16124** onto the back of the front section by sliding the two sections together at the slip-fit connection over the rear axle. Then place the rear of the tailpipe into the clamp hanger. Install a 2 1/2" clamp on the over-axle slip-fit connection and tighten enough to hold, but still allow for adjustment.
- 9) Slide side exit pipes **#16317** or rear exit pipes **#16397** through the clamp hangers and onto the back of the tailpipes. Adjust the position of the tailpipes and tighten the clamp assemblies to hold them in place. Place **#ST396** stainless tips onto the exit pipes and tighten enough to hold, but still allow for adjustment.
- 10) Adjust the position of all pipes and muffler to provide a satisfactory fit. A minimum of 3/4" clearance around all parts of the system must be maintained; while also keeping suspension travel and vibration in mind.
- 11) Tighten all clamped connections down securely. Slide a 7/16" hanger keeper onto the end of the two hangers behind the muffler and also onto all round hanger mounts. These will prevent the rubber hangers from sliding off.
- 12) For a cleaner appearance and more secure installation, we highly recommend welding all slip-fit connections. If you live in a geographical area that has harsh winters or sees a great deal of precipitation, the use of high temperature paint over the welded areas can help to prevent surface rust and premature corrosion.

## PACKING LIST

| <u>Qty</u> | <u>Description</u>           | <u>Part#</u> |
|------------|------------------------------|--------------|
| 1          | Adapter pipe                 | TB230        |
| 1          | Muffler                      | 530552       |
| 1          | Tailpipe (R)                 | 16127        |
| 1          | Tailpipe (Front L)           | 16128        |
| 1          | Tailpipe (Rear L)            | 16124        |
| 2          | Exit Pipe (Side)             | 16317        |
| 2          | Exit pipe (Rear)             | 16397        |
| 2          | Stainless Tip                | ST396        |
| 1          | Parts kit                    | PK302        |
| 4          | 2 1/2" clamp                 | MC250S       |
| 1          | 3" clamp                     | MC300G       |
| 2          | Frame Hanger                 | 208HA        |
| 2          | Clamp Hanger                 | 209HA        |
| 1          | Frame Hanger                 | 211HA        |
| 2          | Rubber hanger                | HA168        |
| 2          | 5/16" x 1" Bolt              | HW204        |
| 2          | 5/16" Nut                    | HW102        |
| 2          | 5/16" lock washer            | HW308        |
| 2          | 1/4" x 1" Bolts              | HW202        |
| 2          | 1/4" Lock Washers            | HW307        |
| 2          | 1/4" Nuts                    | HW101        |
| 6          | 7/16" Hanger Keepers         | HW502        |
| 2          | 3/8" x 1 3/4" Shoulder Bolts | HW216        |
| 2          | 3/8" Flat Washers            | HW303        |



Installation diagram for:  
**SYSTEM #17429**  
1994-2001 DODGE RAM TRUCK  
5.2L & 5.9L V8 ENGINES · ALL WHEELBASES

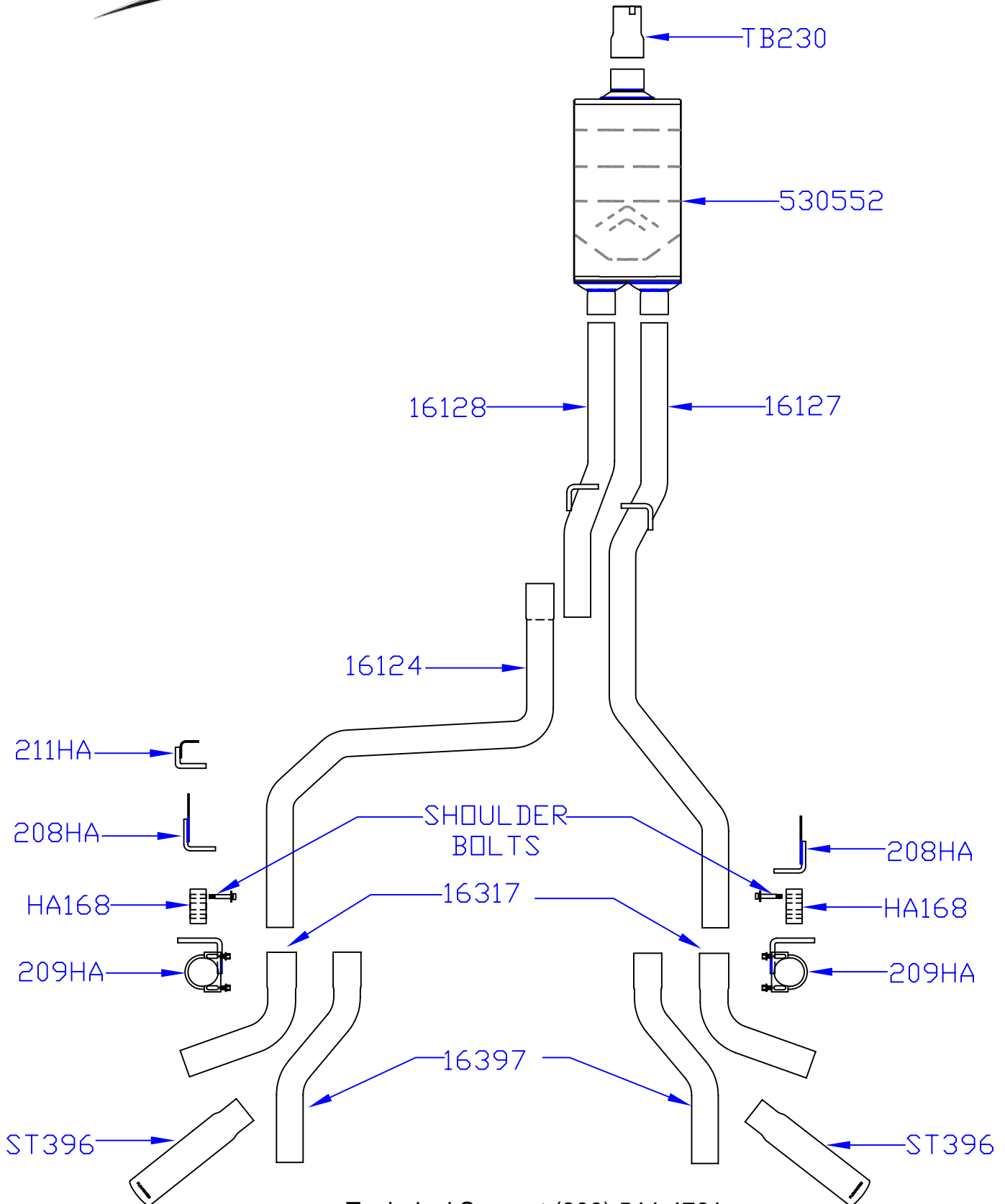

Technical Support (800) 544-4761