

banks

with Installation Instructions
Owner's Manual

Banks Ram-Air® Intake System

**2006-2007 Chevrolet 6.6L (LBZ)
Duramax Turbo-Diesel Classic Pickups**

THIS MANUAL IS FOR USE WITH KIT 42142

Gale Banks Engineering
546 Duggan Avenue • Azusa, CA 91702
(626) 969-9600 • Fax (626) 334-1743

Product Information & Sales: (888) 635-4565

bankspower.com

General Installation Practices

Dear Customer,

If you have any questions concerning the installation of your Banks Ram-Air System, please call our Technical Service Hotline at (888) 839-2700 between 7:00 am and 5:00 pm (PT). If you have any questions relating to shipping or billing, please contact our Customer Service Department at (888) 839-5600.

Thank you.

1. For ease of installation of your Banks Ram-air intake system, familiarize yourself with the procedure by reading the entire manual before starting work. This manual contains 14 pages of copy, illustrations and parts listing. If any pages are missing from this manual please call Gale Banks Engineering immediately for a replacement.
2. The exploded view of the Ram-Air assembly (pages 4-5) provides only general guidance. Refer to each step and section diagram in this manual for proper instruction.
3. Throughout this manual, the left side of the vehicle refers to the driver's side, and the right-side to the passenger's side.
4. Disconnect the ground cable from the battery before beginning work. If there are two batteries, disconnect both.

5. Route and tie wires and hoses a minimum of 6 inches away from exhaust heat, moving parts and sharp edges. Clearance of 8 inches or more is recommended where possible.

6. During installation, keep the work area clean. If foreign debris is transferred to any Banks system component, clean it thoroughly before installing.

7. When raising the vehicle, support it on properly weight-rated safety stands, ramps or a commercial hoist. Follow the manufacturer's safety precautions. Take care to balance the vehicle to prevent it from slipping or falling. When using ramps, be sure the front wheels are centered squarely on the topsides; put the transmission in park; set the parking brake; and place blocks behind the rear wheels.

Caution! Do not use floor jacks to support the vehicle while working under it. Do not raise the vehicle onto concrete blocks, masonry or any other item not intended specifically for this use.

Notification

The Banks Ram-Air Filter comes pre-oiled and no oiling is necessary for initial installation. Service the filter as specified in the Filter Maintenance Section of this manual.

Tools Required:

- 1/4" or 3/8" drive ratchets with metric sockets
- Standard and Phillips head screwdrivers
- Clean shop towels or rags
- 5/16" nut driver

Table of Contents

Section 1 **4**
General Assembly

Section 2 **6**
Ram-Air Installation

Section 3 **13**
Filter Maintenance

Section 1

General Assembly

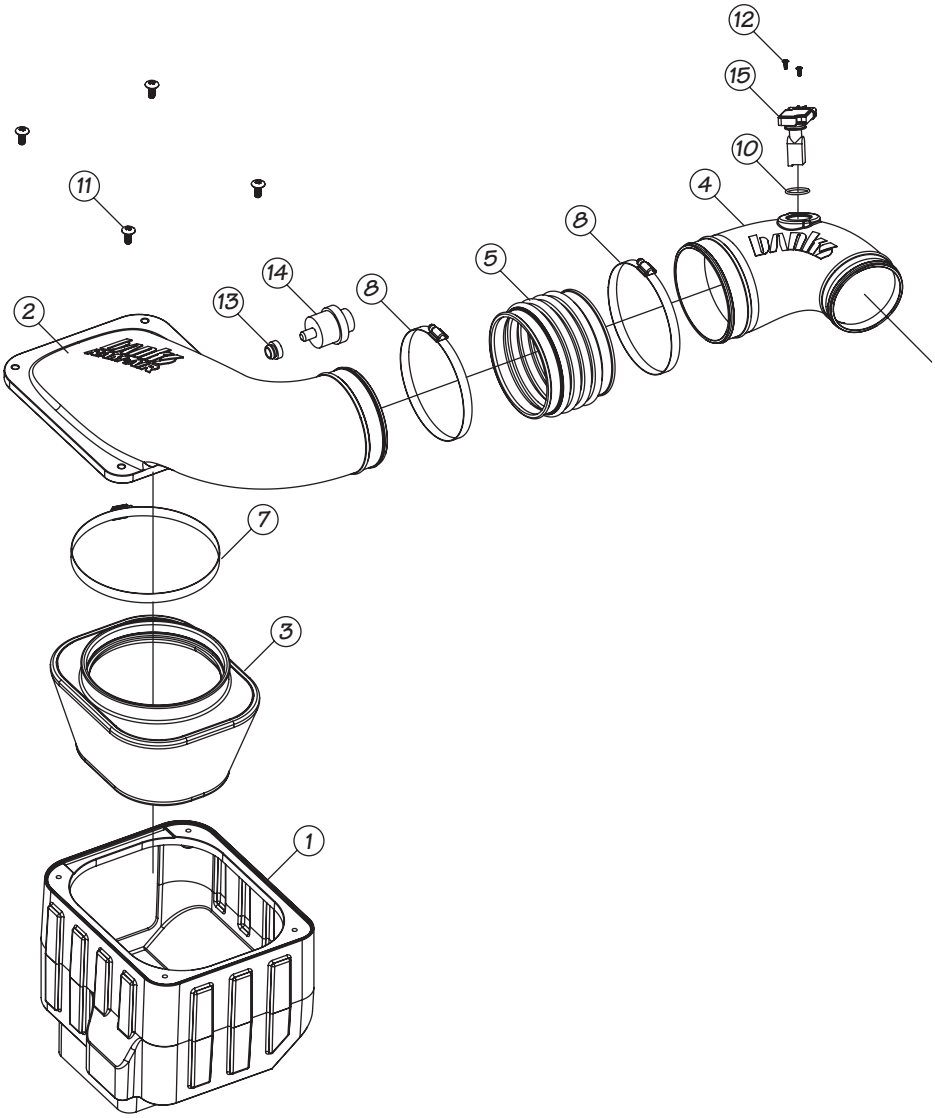

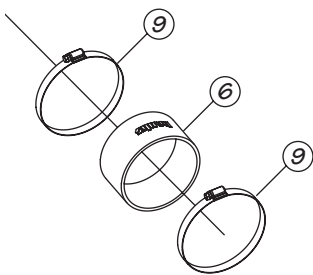

Item	Description	Part#	Qty
1	FILTER HOUSING, Ram-Air	42136	1
2	FILTER HOUSING COVER, Ram-Air	42143	1
3	AIR FILTER ELEMENT	42138	1
4	INTAKE TUBE, Ram-Air	42152	1
5	HOSE, BELLOWS, 5.30 I.D.	94302	1
6	HOSE, TURBO INTAKE	94301	1
7	HOSE CLAMP, #128	92928	1
8	HOSE CLAMP, #88 w/LINER	92868	2
9	HOSE CLAMP, #72 w/LINER	92872	2
10	O-RING, MAF	93740	1
11	SCREW, TRUSS HEAD, PHILLIPS, 5/16-18 X 3/4	91226	4
12	SCREW, TRUSS HEAD, PHILLIPS, 6-32 X 3/8	91718	2
13	STOCK GROMMET, FILTER MINDER	*	
14	STOCK FILTER MINDER	*	
15	STOCK MAF SENSOR	*	
16	TORX TOOL, T20H (Not shown)		1

Section 2

RAM-AIR INSTALLATION

You are about to install the Banks Ram-Air Intake System. Read and follow all steps before working on the vehicle. Some components from the stock air intake system will remain in service. Take care when removing stock air intake components to not damage them.

Use the Bill of Materials Chart and the General Assembly Drawing to reference component nomenclature and location. Use caution when working in the engine compartment. Make sure the engine has been OFF for several hours and cool.

1. Loosen the hose clamp that holds the stock intake air tube to the turbo intake tube.
2. Loosen and separate the stock hose clamp on the intake tube that is connected to the stock air box cover. See **Figure 1**.

3. Separate the stock intake tube connected to the turbo intake. Remove the stock intake tube from the engine and set aside.

4. Remove the Air Flow (MAF) sensor connector from stock air box filter cover.

Note: Be careful not to damage the connector or the MAF sensor during this process.

5. Remove stock air box by lifting the air box up and out. The bottom of the stock air box is held in place by rubber grommets. There may be some slight resistance when removing the stock air box.

6. Next, remove the stock air box bolts accessible from the top of the engine compartment as shown. Then remove the stock air box tray. See **Figure 2**. Keep the previously removed bolts for reassembly later in the installation process.

Figure 1

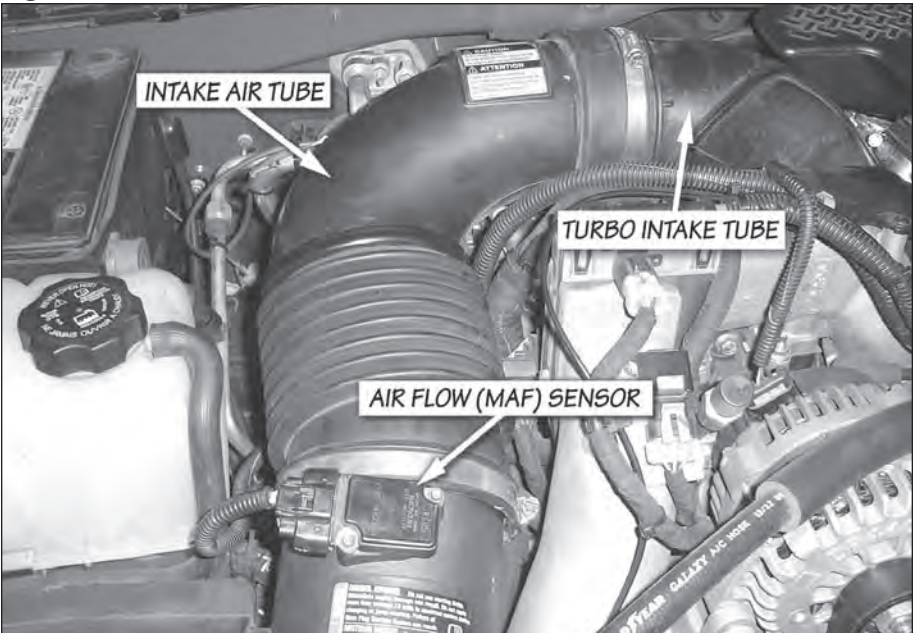
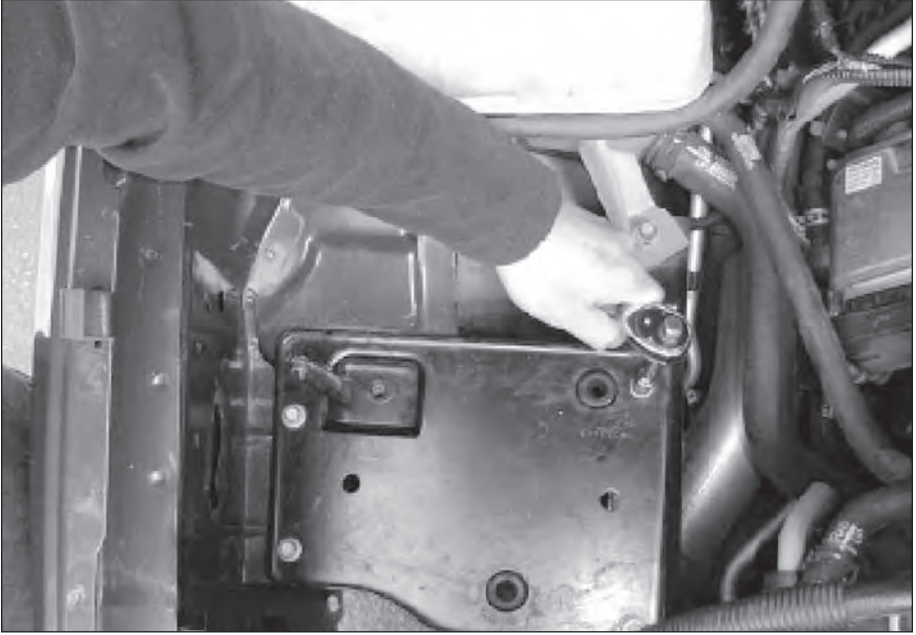

Figure 2



7. Locate your Banks Ram-Air filter housing from your kit. Align the Banks Ram-Air filter housing to fit parallel to fender edge. Install and tighten the previously removed bolts to secure the Banks Ram-Air filter housing.

*Note: The cutout on Banks Ram-Air filter housing must face passenger side fender. See **Figure 3**.*

8. Locate your Banks Torx tool, T20H in your Banks Ram-Air kit. Use the Torx tool bit to remove the two (2) screws securing the MAF sensor to the stock air box cover.

Note: Be careful when removing the MAF Sensor. When removing the MAF sensor, grasp its body and pull up and out. Do not twist or bend when removing.

9. Install the supplied Banks MAF sensor o-ring onto the MAF sensor. Ensure o-ring is mounted flush to MAF sensor edge as shown (**Figure 4**).

Note: Retain the stock O-ring. The Banks o-ring will be slid over the stock o-ring on the MAF sensor.

10. Locate your Banks Ram-Air intake tube in your kit. Install the stock MAF sensor (with the additional Banks gasket) to MAF sensor mounting boss as shown. Tighten the screws (included) to 3 in/lbs. See **Figure 5**.

Note: Ensure correct alignment as shown otherwise screw holes will not align with screw holes in the Banks Ram-Air intake tube.

Caution: DO NOT OVER TIGHTEN SCREWS

Figure 3

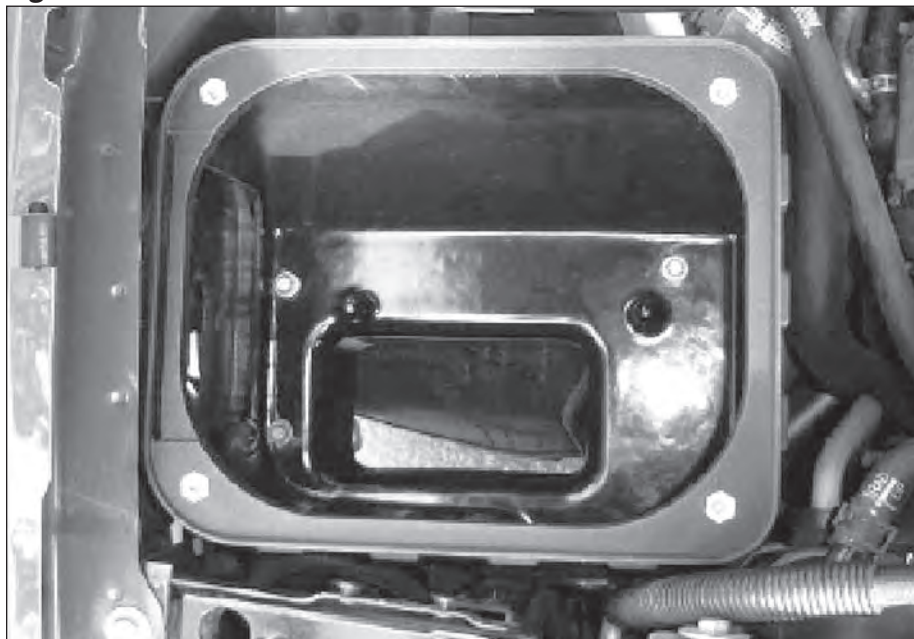

Figure 4

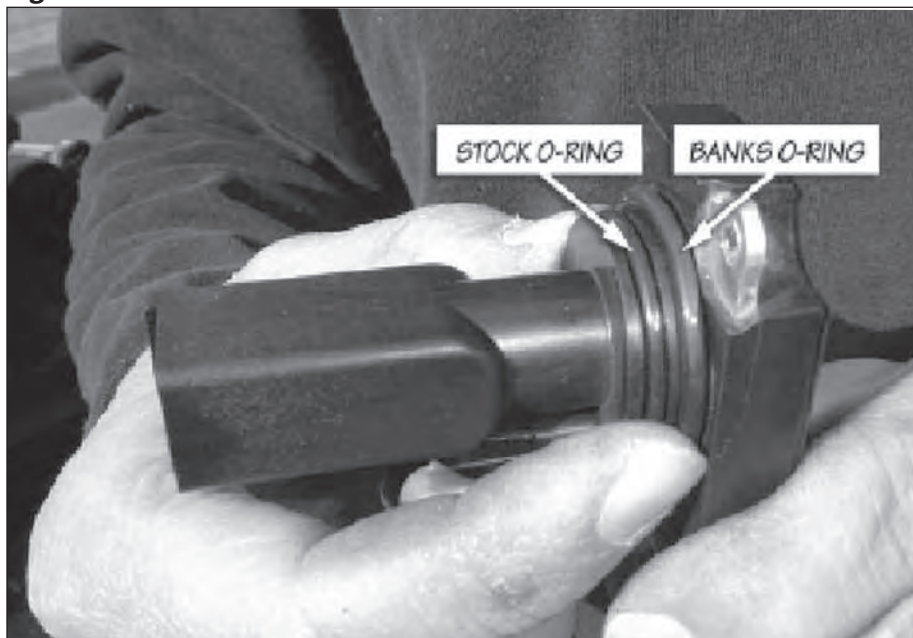
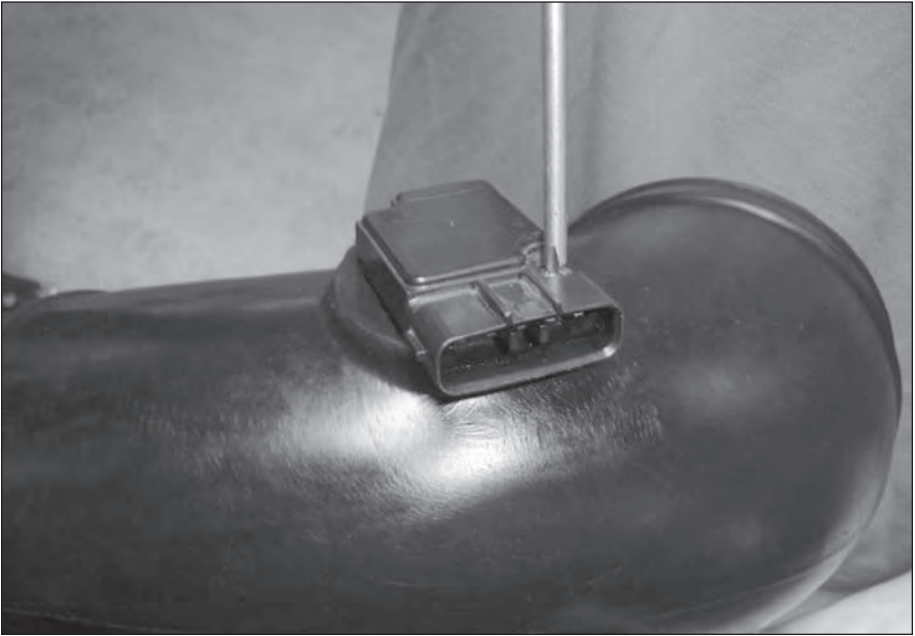

Figure 5



11. Locate the previously removed stock air box and remove the stock air filter Minder. Make sure to remove the stock air filter Minder rubber grommet as well. See **Figure 6**.

12. Locate the Banks Ram-Air filter housing cover. Install the air filter Minder's rubber grommet into the Banks Ram-Air filter housing cover. Once the rubber grommet is installed flush into the Banks Ram-Air cover, then the filter Minder can be inserted into the rubber grommet. Make sure the air filter Minder is installed flush to rubber grommet.

13. Locate the Banks Ram-Air filter element and the Banks air filter hose clamp. Loosely fit the filter clamp to the air filter element.

*Note: See **Figure 7** to reference the correct alignment locator groove to the Banks Ram-Air filter.*

14. After verifying the alignment between the Banks Ram-Air filter and the Banks Ram-Air cover, press fit the two pieces together until an audible snap is heard. This process will ensure that a correct seal has been established.

15. Tighten the Banks Ram-Air filter hose clamp to the Banks Ram-Air filter cover.

16. Place the Banks Ram-Air filter cover onto the Banks Ram-Air housing. Align and loosely fit the cover onto the housing.

17. Install, but do not tighten, the Banks bellows hose and hose clamp onto the Banks Ram-Air housing cover.

18. Locate the Banks turbo intake hose, tube, and hose clamps from your Banks Ram-Air kit. Loosely assemble the Banks intake hose to the Banks intake tube with the supplied hose

Figure 6



Figure 7

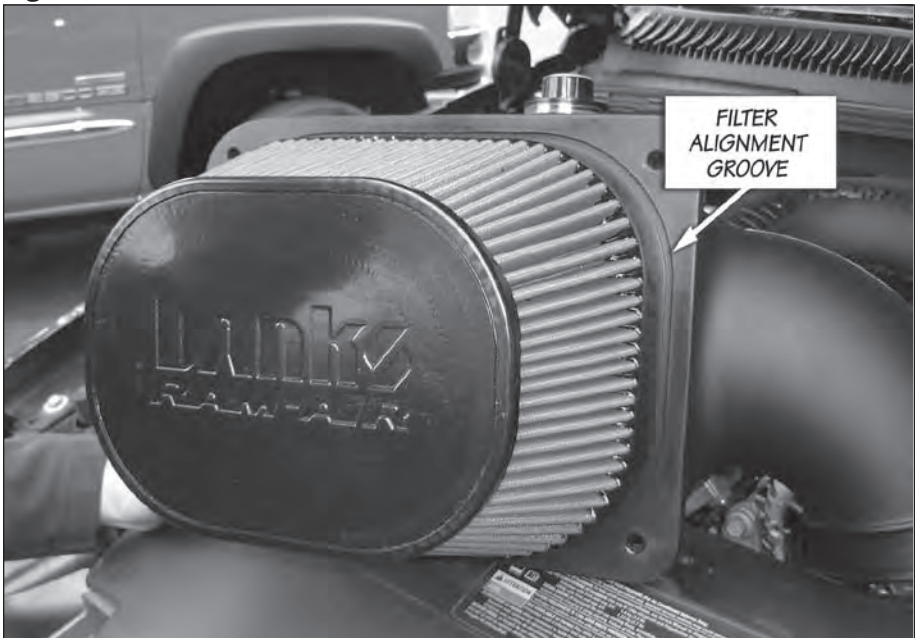

clamps. Attach the turbo intake hose to the turbo intake tube. Leave the hose clamps loose.

19. Install the Banks Ram-Air intake tube into the Banks bellows. Tighten all the hose clamps to secure the Banks intake tube. See **Figure 8**.

CAUTION: Ensure Intake tube is not touching any engine components.

20. Fasten the Banks air filter cover to the Banks air filter housing using the Banks cover screws and tighten.

21. Re-attach the MAF sensor connector to the MAF sensor in the Banks intake tube.

Note: You may have to loosen the wire harness clips to increase the slack in the wiring harness to allow the MAF connector to reach the MAF sensor in the Banks intake air tube (Figure 9).

22. Re-connect battery grounds. You have successfully completed the installation of the Banks Ram-Air Intake system. See **Figure 10**. Make sure to check all hose clamps for tightness and connectors for a sure fit. Make sure that the intake tube is not touching any engine components.

Figure 8



Figure 9

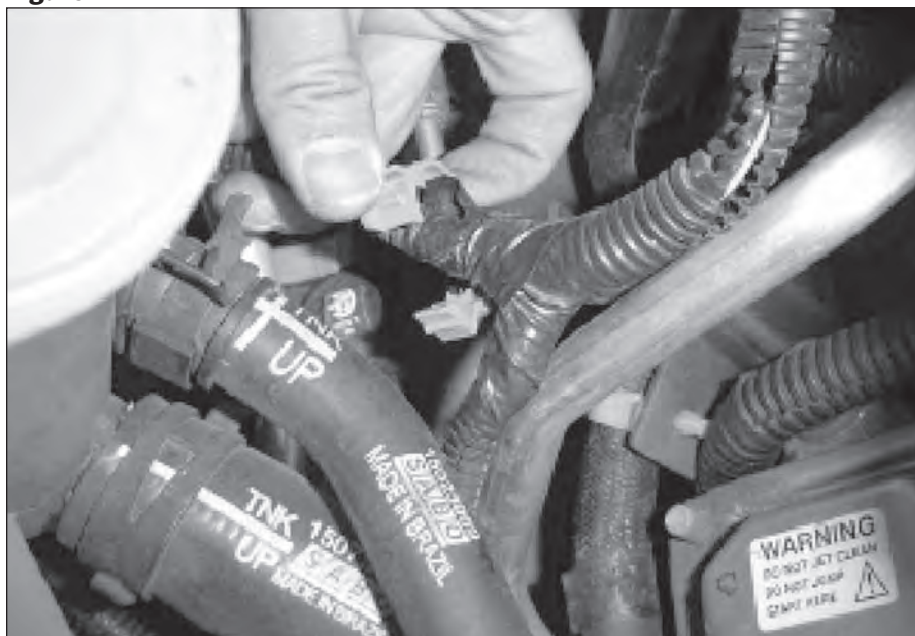
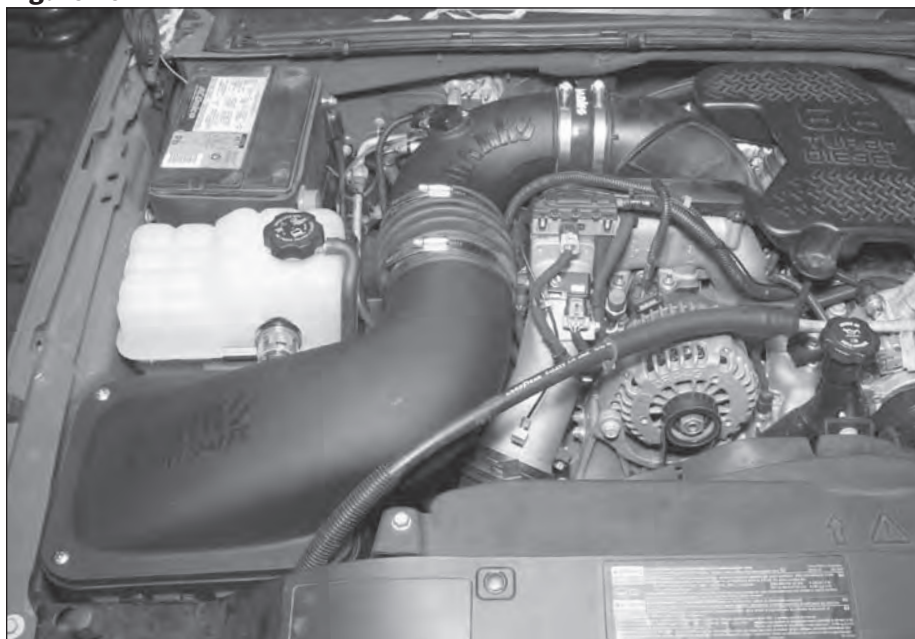

Figure 10



Section 3

FILTER MAINTENANCE

Notification

The Banks Ram-Air Filter comes pre-oiled and no oiling is necessary for initial installation. Service the filter as specified in steps 1-2 of this Section.

1. Service Banks Ram Air Filter every 50-100,000 miles on street-driven applications. Service more often in off-road or heavy-dust conditions. If an air-filter restriction gauge is installed, then clean the element when the air-filter restriction gauge enters the restrictive red zone. See **Figure 11**.

2. Use Banks Ram Air Filter cleaning system (part # 90094), available from Gale Banks Engineering to service the Air Filter. Follow the instructions included with the cleaning system to clean and re-oil your Banks Ram-Air Filter. No gasoline cleaning, No steam cleaning, No caustic cleaning

solutions, No strong detergents, No high pressure car wash, No parts cleaning solvents. Any of these No's can cause harm to the cotton filter media plus SHRINK and HARDEN the rubber end caps.

CAUTION! Extremely fine dust from agriculture or off-road use will pull the oil from the element. Frequent re-oiling of the element's clean side might be required. Completely service when practicable. For extra protection use an air-filter sealing grease on rubber ends of the element. Service only with Banks Ram-Air filter cleaner and Banks Ram-Air filter oil.

Figure 11 Typical air-filter restriction gauge

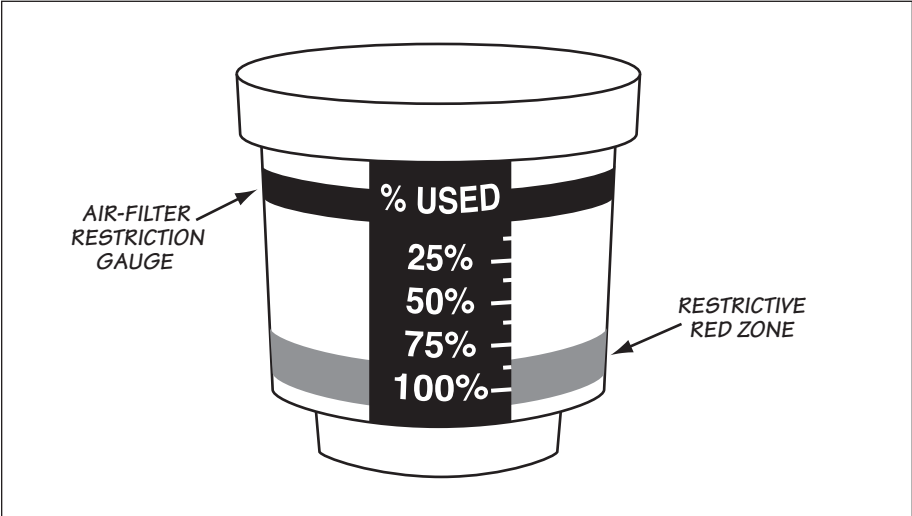

Gale Banks Engineering
546 Duggan Avenue • Azusa, CA 91702
(626) 969-9600 • Fax (626) 334-1743

Product Information & Sales: (888) 635-4565

bankspower.com