

S62240

03-07 Ford F250/350 6.0L POWERSTROKE,
TURBO BACK, EC/CC, 5" SINGLE SIDE

MBRP INC.

PERFORMANCE EXHAUST

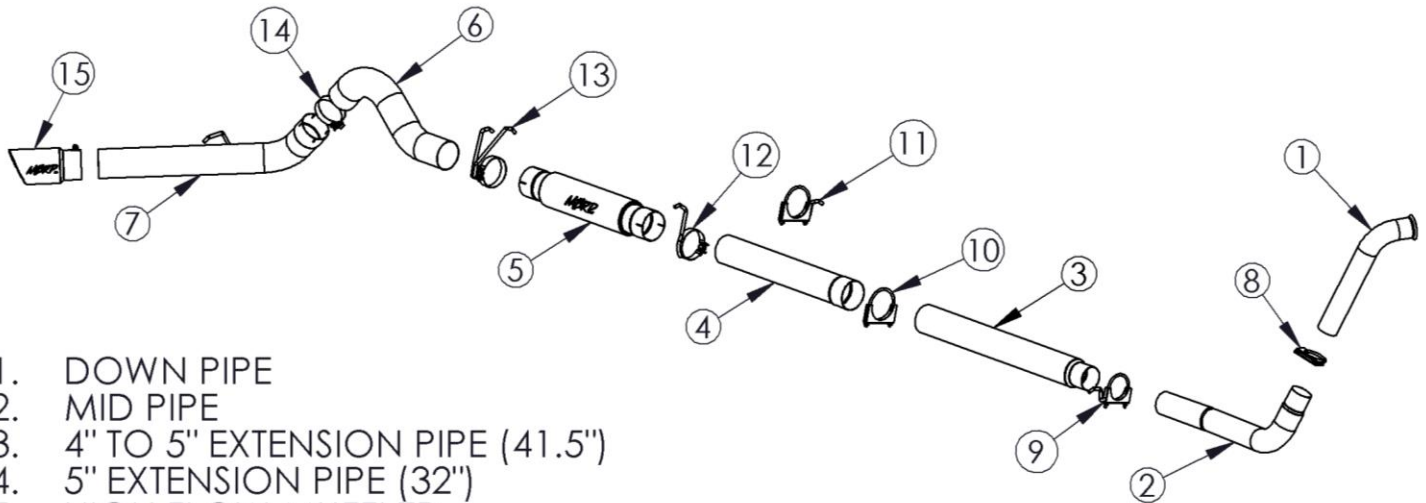

1. DOWN PIPE
2. MID PIPE
3. 4" TO 5" EXTENSION PIPE (41.5")
4. 5" EXTENSION PIPE (32")
5. HIGH FLOW MUFFLER
6. OVER-AXLE PIPE
7. TAIL PIPE
8. 3.5" CLAMP
9. 4" HANGER CLAMP
10. 5" CLAMP
11. 5" HANGER CLAMP
12. 5" HANGER BAND CLAMP
13. 5" HANGER BAND CLAMP
14. 5" BAND CLAMP
15. EXHAUST TIP

PLEASE READ BEFORE STARTING INSTALLATION

While MBRP Inc. has made every effort to ensure that all components of this system are of superior quality and properly packaged it is the installer's responsibility to ensure the following before removal of the factory exhaust:

- that ALL components shown above are present.
- that ALL mating components fit together.
- that there are no damaged components.
- that the system you have purchased is appropriate for your vehicle year, model and configuration.
- that the system will not interfere with any modifications previously installed or planned.
- that you have read and understand these instructions.

If you have any questions or are uncertain about any aspect of the installation of this system to your vehicle please contact your dealer before commencing installation.

Removal of Stock System:

1. Apply penetrating lubricant to all fasteners, hangers, and rubber insulators.
2. Loosen the nut on the band clamp located behind the catalytic converter.
3. Remove the muffler and tail pipe from the OEM rubber hangers. On 03-04 trucks remove bottom shock bolt of the passenger side shock to remove the system in one piece. **This is not required on 05 and newer models.** Separate the stock exhaust at the slip joint located behind the catalytic converter and remove the muffler and tail pipe from under the truck. **Re-install the bottom shock bolt.**
4. Remove the catalytic converter by removing the two nuts holding the inlet flange together using. Retain the nuts for the re-installation of the catalytic converter.
5. Remove the down pipe from the turbo by removing the clam. Retaining the clamp for the installation of the new down pipe. Cut the down pipe in front of the transmission cross member to remove. (**Note:** The stock down pipe can be removed in one piece by removing the transmission cross member. It is recommended that this only be done by qualified, trained professionals using tools and equipment designed to safely carry out this procedure.)
6. Remove the spare tire. You may not be able to re-install your spare tire after the installation of this exhaust system.

Installation of MBRP Inc. Performance Exhaust:

1. Install the **Down Pipe** in the same position as the stock down pipe and attach the flared end to the turbo using the stock band clamp. Do not tighten fully until all components are in place.
2. Attach the **Mid Pipe** to the **Down Pipe** using the **3.5" Clamp** to secure the slip joint.
3. Install the **4" to 5" Extension Pipe (41.5")** over the **Mid Pipe**. This pipe is pre-cut to fit an Extended Cab Short Bed truck. For Crew Cab Long Bed vehicles you will require the full length of both the **32" Extension Pipe** and the **41.5" Extension Pipe**. For Extended Cab Long Bed and Crew Cab Short Bed vehicles the **32" Extension Pipe** will have to be cut. For Extended Cab Long Bed vehicles attach the two Extension Pipes and cut the **32" Extension Pipe** to the combined, attached length of 59.1". For Crew Cab Short Bed vehicles attach the two Extension Pipes and cut the **32" Extension Pipe** to the combined, attached length of 57.3".
4. Install the **Hanger Clamp** into the OEM rubber hanger located on the frame beside the inlet of the **Muffler**.
 5. Install the **Muffler** over the **Extension Pipe** so that the exhaust will flow smoothly over the louvers. (See figure on the left)
 6. Install the **Hanger Clamp** into the two OEM rubber hangers located above the outlet of the **Muffler**.
 7. Install the **Tail Pipe** and **5" Band Clamp** onto the **Over-Axle Pipe**. From the rear of the truck, slide the assembly over the axle and attach to the outlet of the **Muffler**. Install tail pipe hanger into the OEM hanger to complete.
 8. Install the provided clamps around pipes where needed. Adjust the **Tail Pipe** and check along the whole length of the exhaust system to ensure there is adequate clearance around the fuel and brake lines or any wiring. If there any interference is detected relocate and adjust.
9. Install and adjust the **Exhaust Tip** to suit. Tighten the lock bolt located on **Exhaust Tip**.
10. Make sure exhaust is in place before tightening clamps. Start at the front of the exhaust system and begin tightening all connections.

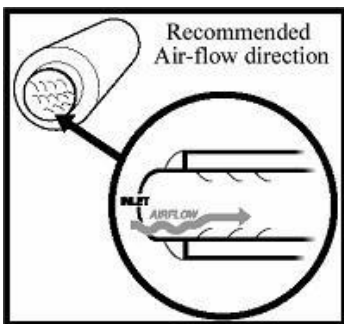

Congratulations! You are ready to begin enjoying the improved performance and driving experience of your MBRP Inc. performance exhaust system. We hope you enjoy your purchase.