

# S61160

04.5-07 DODGE 2500/3500 "600/610"  
5.9L CUMMINS, TURBO BACK, OFF ROAD,  
5" SINGLE

**MBRP**  
INC.  
PERFORMANCE EXHAUST

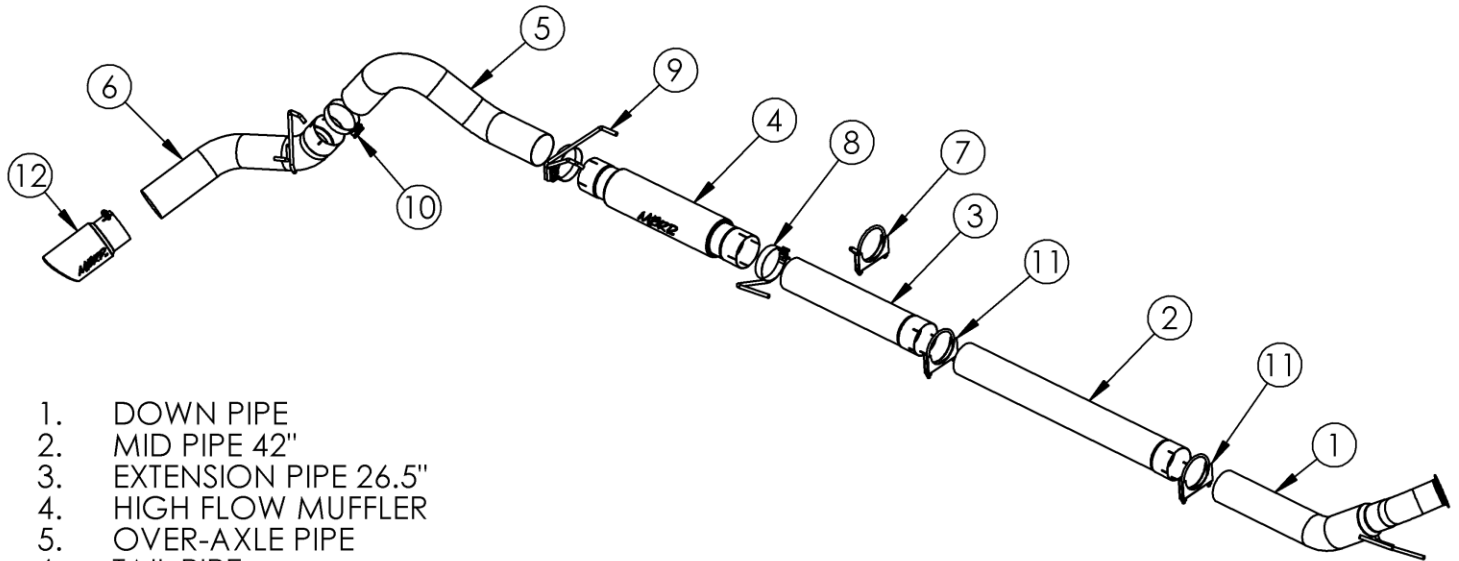

1. DOWN PIPE
2. MID PIPE 42"
3. EXTENSION PIPE 26.5"
4. HIGH FLOW MUFFLER
5. OVER-AXLE PIPE
6. TAIL PIPE
7. 5" HANGER CLAMP
8. 5" HANGER CLAMP
9. 5" HANGER CLAMP
10. 5" BAND CLAMP
11. 5" CLAMP (2 PCS)
12. EXHAUST TIP

## PLEASE READ BEFORE STARTING INSTALLATION

**While MBRP Inc. has made every effort to ensure that all components of this system are of superior quality and properly packaged, it is the installer's responsibility to ensure the following before removal of the factory exhaust:**

- that ALL components shown above are present.
- that ALL mating components fit together.
- that there are no damaged components.
- that the system you have purchased is appropriate for your vehicle year, model and configuration.
- that the system will not interfere with any modifications previously installed or planned.
- that you have read and understand these instructions.

If you have any questions or are uncertain about any aspect of the installation of this system to your vehicle please contact your dealer before commencing installation.

### Removal of stock system:

1. Apply a penetrating lubricant liberally to all exhaust fasteners, hangers and rubber insulators.
2. Remove the exhaust system from the rubber insulators and remove all of the clamps from the system.
3. Separate the slip joint behind the muffler and remove the tail pipe. Next, separate the slip joint located behind the catalytic converter and remove the muffler and extension pipe. Remove the catalytic converter by separating the slip joint located between the down pipe and the catalytic converter. Now loosen the clamp connecting the down pipe to the turbo and remove the down pipe. **Do not discard the clamp as it is required for the installation.**
4. Remove the OEM down pipe hanger bracket from the bellhousing. **Do not discard these parts as they are required for the installation.**
5. Remove the spare tire. You may not be able to reinstall your spare tire after the installation of this exhaust system.

### Installation of MBRP Inc. Performance Exhaust:

1. Slide the OEM down pipe hanger bracket onto the **Down Pipe** hanger. Install the **Down Pipe** in the same position as the stock down pipe by reattaching the hanger bracket to the bellhousing and then attaching the flared end to the turbo using the stock band clamp. Do not fully tighten until all components are in place.
2. Install the **Mid Pipe** onto the **Down Pipe** and then the **Extension Pipe** onto the **Mid Pipe** using the two **5" Clamps** provided. The combination of the **Mid Pipe** and **Extension Pipe** provides the required length to fit a Quad Cab Long Bed truck or Mega Cab. these pipes will have to be cut to fit all other vehicles.  
**Installation Tip:** Temporarily install the **Muffler** and **Tail Pipe** using the factory rubber insulators and the **5" Hanger Clamp**. Measure from the **Muffler** to the **Mid Pipe** to determine the length required. Cut the pipe to the required length.

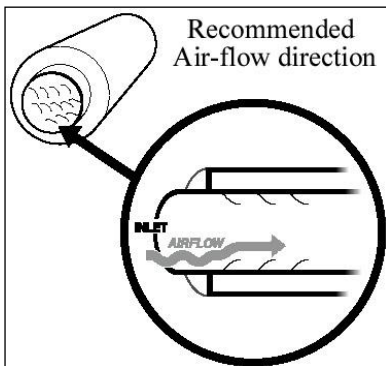

3. Install one of the **5" Hanger Clamps** onto the required pipe into the OEM rubber hanger located on the frame.
4. Install one of the **5" Hanger Clamps** into the OEM rubber hanger located on the frame near the outlet of the **Extension Pipe**.
5. Install the **Muffler** over the required pipe so that the exhaust will flow smoothly over the louvers.  
**Refer to the illustration on the left.**
6. Install the remaining **5" Hanger Clamp** into the two OEM rubber hangers located above the outlet of the **Muffler**.
7. Remove the factory rubber insulator for the factory tail pipe and install it onto the **Tail Pipe** hanger. Install the **Tail Pipe** and **5" Band Clamp** onto the **Over-Axle Pipe**. from the rear of the truck, Slide the assembly over the axle and attach to the outlet of the **Muffler**. Finish hanging the **Tail Pipe**.
8. Adjust the **Tail Pipe** and check along the whole length of the exhaust system to ensure there is adequate clearance around the fuel and brake lines or any wiring. If there is any interference detected, relocate or adjust.
9. Install and adjust the **Exhaust Tip** to suit. Tighten the lock bolt located on the **Exhaust Tip**.
10. Make sure that the exhaust is properly in place before tightening clamps. Start at the front of the exhaust system and tighten all connections.

**Congratulations!** You are ready to begin enjoying the improved performance and driving experience of your MBRP Inc. performance exhaust system. We hope you enjoy your purchase.