



# INSTALLATION INSTRUCTIONS

APPLICATION: 2001 FORD ESCAPE/ MAZDA TRIBUTE

## AUTOMOTIVE PRODUCTS, INC.

STEP BAR  
ASSEMBLIES

**25-1970**  
**25-1975**

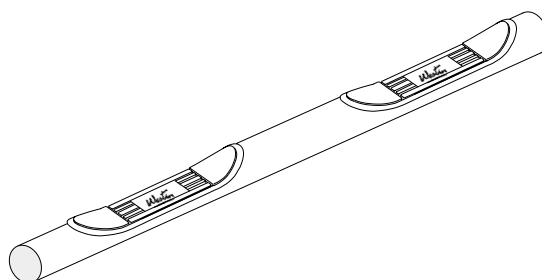

QTY	PARTS KIT CONTENTS DESCRIPTION	TOOLS REQUIRED
2	STEP BAR ASSEMBLY	RATCHET
2	FRONT/CENTER MOUNT BRACKET, PASSENGER	7/32" HEX WRENCH
2	FRONT/CENTER MOUNT BRACKET, DRIVER	13MM SOCKET
1	REAR MOUNT BRACKET, PASSENGER	TORQUE WRENCH
1	REAR MOUNT BRACKET, DRIVER	9/16" SOCKET
4	3/8-16 X 1.50" HEX HEAD BOLTS	
12	3/8-16 X 1.00" BUTTON HEAD CAP SCREW	
8	M8-1.25 X 30MM HEX HEAD BOLT	
8	M8 FLAT WASHER	
8	M8 SPLIT LOCK WASHER	
2	3/8" NUT PLATES	
12	3/8" INTERNAL TOOTH LOCK WASHER	
4	3/8" LOCK WASHER	
4	3/8" SAE FLAT WASHER	

- STEP 1. Remove the contents from the box and check for any damage. Verify all parts against parts list.
- STEP 2. Read and understand instructions completely before beginning installation.
- STEP 3. Remove (4) rubber plugs located on the backside of passenger side rocker panel behind the front tire and underneath front door.
- STEP 4. Attach front and center brackets (same bracket) to the passenger side rocker panel using (4) M8-1.25 x 30MM Hex Head Bolt, (4) M8 Lock Washer and (4) M8 Flat Washer. Thread into holes which plugs were removed. Hand tighten.
- STEP 5. Locate the rear mounting holes (one slot and one hole) on the underside of the rocker panel, below the rear door on the passenger side. Insert (1) 3/8" Nut Plate into slot so holes of Nut Plate line up with mounting holes on vehicle (high side of Nut Plate should face up).
- STEP 6. Attach Rear Bracket to vehicle rocker panel using (2) 3/8-16 x 1.50" Hex Head Bolt, (2) 3/8" Lock washer and (2) 3/8" Flat Washer. Hand Tighten.

- STEP 7. Attach Step bar to brackets using (3) 3/8-16 x 1.00" Button Head bolts and (3) 3/8" Internal Tooth Lock Washers. Hand Tighten.
- NOTE:** Step Pad closer to the end of tube goes to rear of vehicle.
- STEP 8. Repeat for driver side installation.
- STEP 9. Center and level Step bar. Tighten and torque 3/8" fasteners to 30 FT. LBS. and M8 fasteners to 19 FT. LBS.

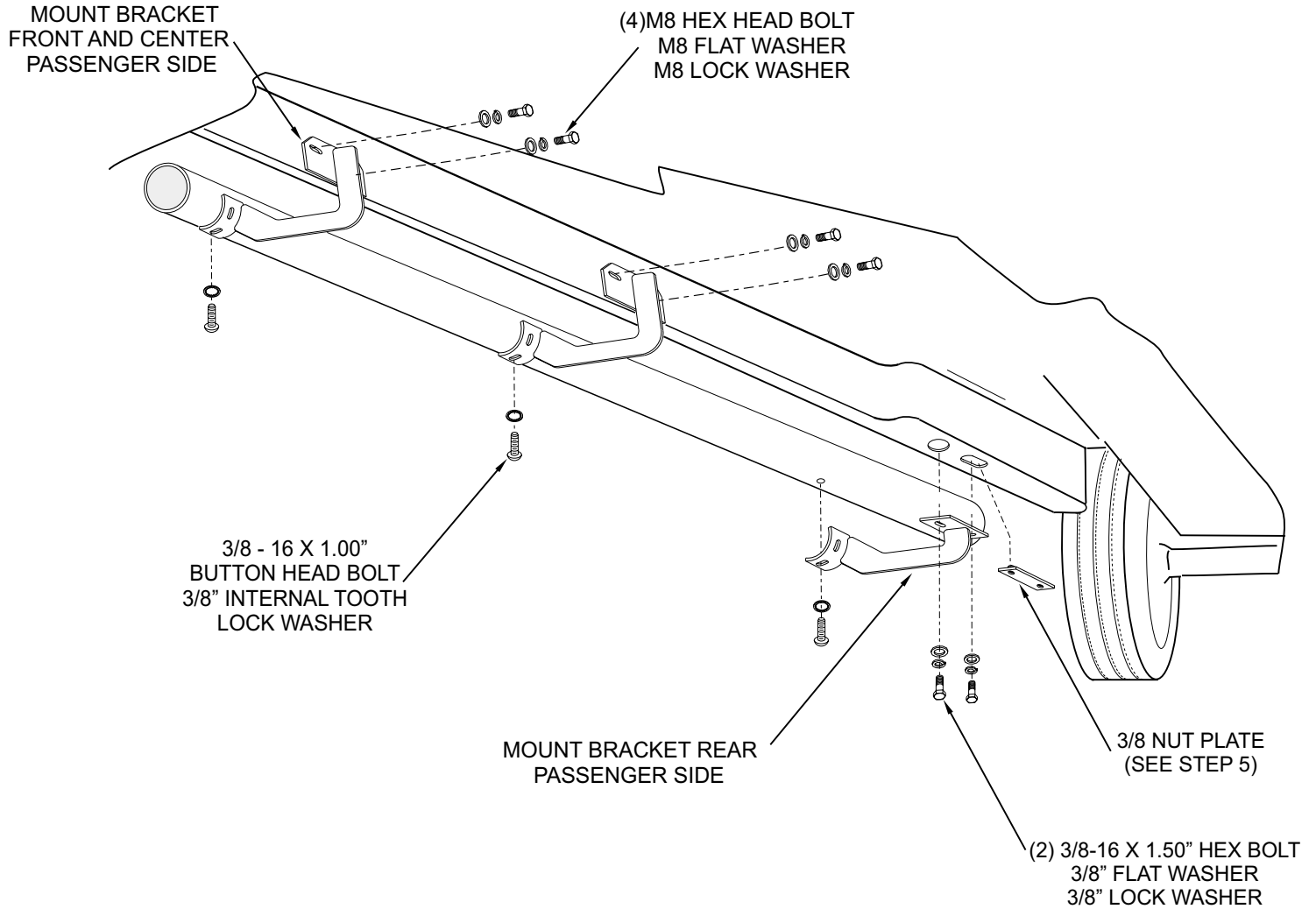

## ASSEMBLY AND INSTALLATION VIEW OF PASSENGER SIDE - DRIVER SIDE OPPOSITE

Finish protection - Westin products have a high quality finish that must be cared for like any other exposed finish on the vehicle. Protect the finish with a non-abrasive automotive wax (pure carnauba, for example) on a regular basis. The use of cleaner wax or any compound which contains an abrasive is detrimental, as the compounds scratch the finish and open it to corrosion.



A subsidiary of Wedgestone Corporation  
15854 Ornelas Street  
Irwindale, Ca. 91706

Thank You for choosing Westin products  
For additional installation assistance please call  
Customer service (800) 793-7846 or (507) 375-3559