



TEL: 1-866-XANATOS

INSTALLATION INSTRUCTIONS

**PART#:17DG100MSS\17DG100MA
MODULAR GRILL GUARD FOR DODGE RAM 94-01**

QTY	DESCRIPTION
1	guard, center section
1	brush guard, left side
1	brush guard, right side
1	wire guard insert, left side
1	wire guard insert, right side
1	lower support bracket-left
1	lower support bracket-right
1	hardware kit

NOTE: Please read this information before assembling. Check components received with components listed above. **NO DRILLING REQUIRED.** Complete step by step instruction sheets will be found on the following pages.

- 1st. Stage, mounting of guard to vehicle.
- 2nd. stage, attaching brush guards to center section.
- 3rd . stage, attaching wire head light guards.

IMPORTANT: To obtain correct installation, we recommend you to follow these step by step instructions carefully.

Illustrations are for reference only, styles vary with application. Please review the instruction sheet before proceeding to assemble product.

Please take care when assembling and installing this product to protect the finish and your investment. To protect your investment, wax this product after installing. Regular waxing is recommended. Do not use any type of polish or wax that contains abrasive that could damage the finish.

INSTALLATION INSTRUCTIONS

1ST STAGE

NOTE: Please read this information before assembling. Check components received with components listed above. **DRILLING IS REQUIRED.** Complete step by step instruction sheets will be found on the following pages.

QTY	DESCRIPTION
8	3/8-16 x 1 1/4 hex bolts, zinc plated GR5
16	3/8 flat washers, zinc plated
8	3/8 split lock washers, zinc plated
8	3/8 hex nuts, zinc plated
2	top support brackets
1	lower support bracket, left side
1	lower support bracket, right side

Step Two: Locate one lower support bracket, left side and one lower support bracket, right side. Position the lower support bracket, left side under the front core support frame mount, located on the outside of the left frame rail behind the front bumper. Remove one bumper bracket bolt located on each side of the support bracket. Place the lower support bracket, left side to the side of the frame, secure the bracket to the frame with the original bolts. Repeat this procedure on the opposite side of the bumper.

Step Three: Position the guard over the front bumper. **"NOTE" if your vehicle has been equipped with a rubber spoiler under the front bumper. You will need to remove two small sections from the spoiler to enable the lower portion of the guard to fit through the spoiler to connect with the support brackets.** Center the guard on the bumper and mark the front side of the spoiler where the lower portion of the guard comes in contact with the spoiler. Place the guard aside for now and remove the sections of the spoiler where you marked. You may also remove the spoiler from the vehicle if you choose not to modify the spoiler.

Step Four: Locate four 3/8-16 x 1 1/4 hex bolts, four 3/8 hex nuts, zinc plated, four 3/8 split lock washers, zinc plated and eight 3/8 flat washers. Position the guard over the front bumper and place the lower portion of the guard through the spoiler. Secure the lower portion of the guard to the mounting brackets with the hardware listed in this step. Fully tighten all hardware used thus far.

Step Five: Locate two top support brackets. Place one top support bracket to the inside of the side plate. Line up the hole in the top support bracket with the hole in the side plate. Mark the top of the bumper through the other hole in the top support bracket. Repeat this procedure on the other side plate. Place the top support

bracket aside for now and center punch the bumper where you marked. Drill a 3/8 hole in the bumper where you marked. **"CAUTION" before drilling be sure to check the back side of the drilling area for possible hazards or obstructions.**

Step Six: Locate the remaining hardware from step one. Position the top support brackets in place on the top of the bumper. Secure the brackets to the side plates and the bumper with the hardware listed in this step. Fully tighten all hardware used thus far and proceed ahead to stage two of the instruction sheet.

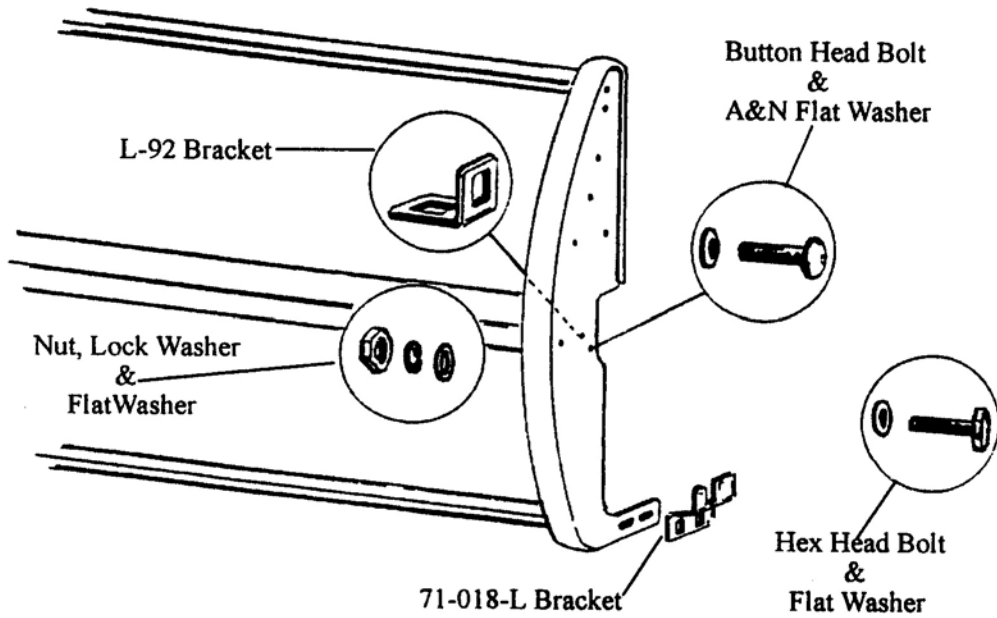

Illustrations are for reference only, styles vary with application. Please proceed to next page of the instruction sheet.

IMPORTANT: To obtain correct installation, we recommend you to follow these step by step instructions carefully.

Please take care when assembling and installing this product to protect the finish and your investment. To protect your investment, wax this product after installing. Regular waxing is recommended. Do not use any type of polish or wax that contains abrasive that could damage the finish.

INSTALLATION INSTRUCTION

2nd STAGE

Step One: Locate hardware. Check contents with the hardware listed below.

QTY	DESCRIPTION
6	M8-1.25 x 20 button head bolts, stainless steel
6	M8-1.25 acorn nuts, stainless steel
12	M8 flat washers, stainless steel
2	rubber gaskets

Step Two: Securing brush guards to center section. Locate the following item's listed below.

QTY	DESCRIPTION
1	brush guard, left side
1	brush guard, right side

Assemble the brush guards to the center section of the guard as shown in illustration below. Use the hardware from step one to secure the parts together. Be sure to fully tighten all hardware at this time. Proceed ahead to stage four of the instruction sheet.

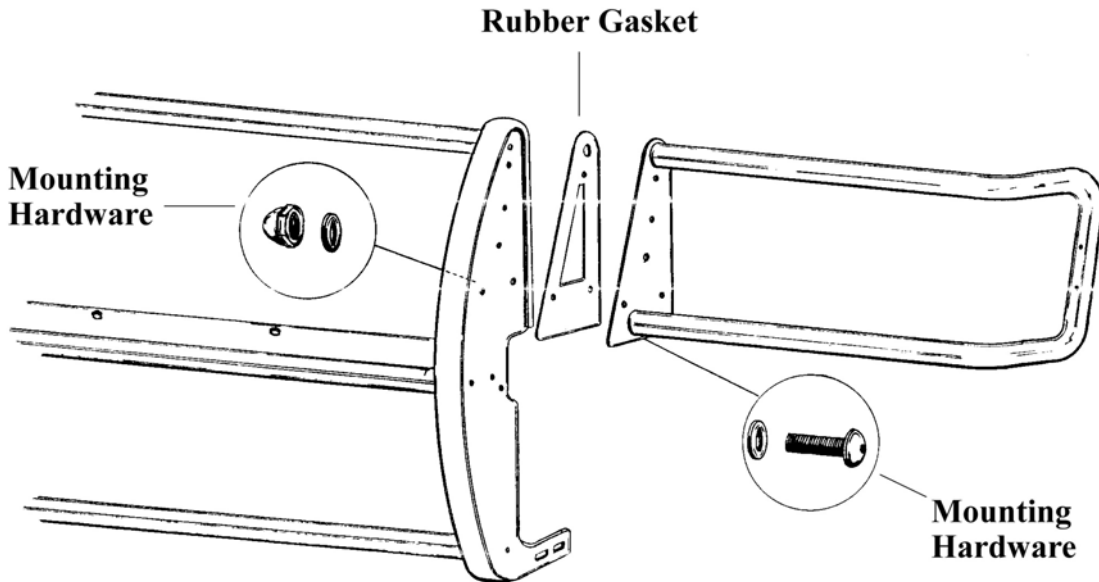

INSTALLATION INSTRUCTION

3rd STAGE

Step One: Locate hardware. Check contents with the hardware listed below.

QTY	DESCRIPTION
8	M6-1.00 x 25mm button head bolts, stainless steel
4	M6-1.00 acorn nuts, stainless steel
12	M6 flat washers, stainless steel
4	rubber gaskets

Step Two: Securing wire insert to brush guards. Locate the following item's listed below.

QTY	DESCRIPTION
2	wire guard insert, left & right side

Attach one rubber gasket to each end of the wire guard. Peel the paper backing off the rubber gasket. Place the gasket on the end of the bracket and press firmly till the gasket is secured in place.

Position the wire insert on the driver's side of the vehicle. Align the two holes in the bracket with the two holes in the brush guard as shown in illustration below. Using the hardware listed in step one, secure the wire insert to the brush guard. Be sure to fasten both ends before fully tightening hardware. Repeat this procedure on the opposite side of the vehicle. Be sure to use all hardware supplied and tighten all bolts.

