

VOLANT COOL AIR INTAKES  
 PART NO.: 163576  
 INSTALLATION INSTRUCTIONS  
 WWW.VOLANT.COM  
 TECH SUPPORT: (909) 481-3888

163576 PARTS LIST				
1	VOLANT FILTER BOX	2	#064 CLAMPS	
1	VOLANT FILTER BOX ADAPTER	1	3 1/2" X 2 3/4" SLEEVE	1
				VOLANT BRACKET (SHORT)
1	VOLANT DUCT	1	4" X 3' HUMP HOSE	1
1	RAM FILTER W/CLAMP	2	1/4"-20 BOLTS	1
		2	1/4" WASHERS	1
2	#056 CLAMPS			1
				1/2" X 11" VINYL TRIM

TOP VIEW

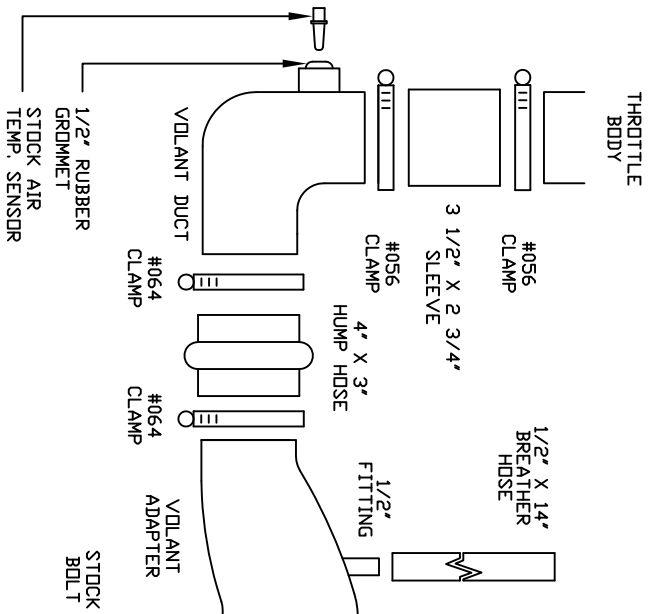

FRONT VIEW

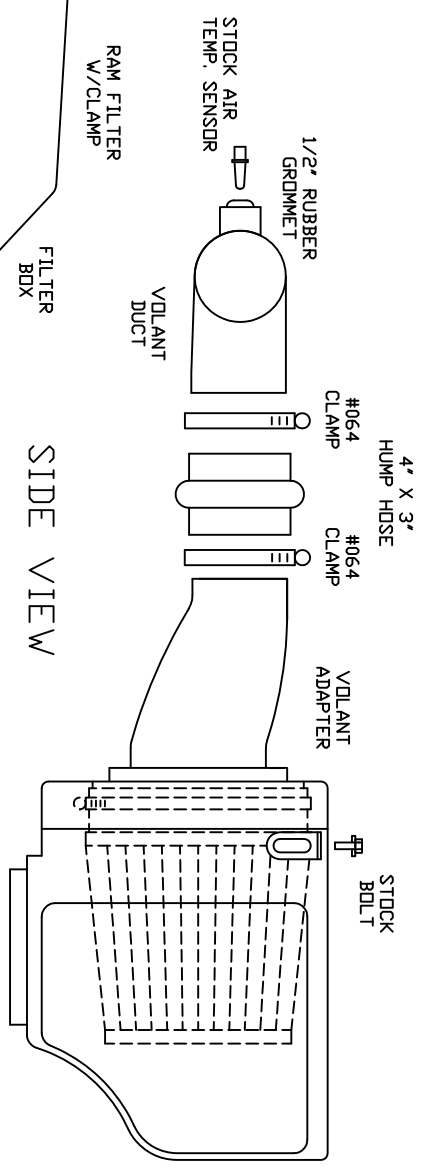

SIDE VIEW

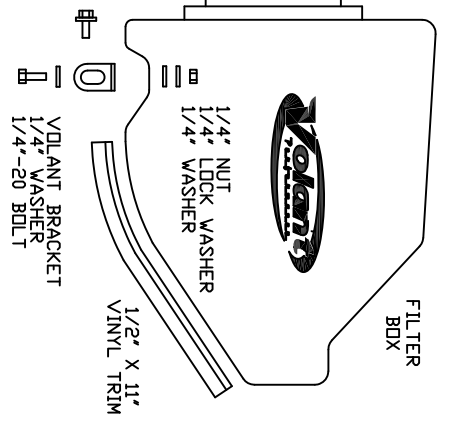



## Installation Instructions

16357 / 163576

Chrysler 300 11-13 5.7L

Dodge Charger 11-13 5.7L



Disconnect the negative battery cable and remove the engine cover by lifting up and pulling out.



Place the filter in the volant box and tighten the clamp through the access hole in the air box.



Press the ATS sensor into the rubber grommet.



Disconnect the wiring harness from the AIT sensor than twist the sensor and pull straight out.



Mount the volant air box in the factory location using the supplied hardware and the stock bolt.



Press the duct inside of the hump hose and sleeve and tighten the clamps.



Loosen the clamps holding the duct to the throttle body and air box. Remove the factory breather hose.



Install the supplied trim sponge on the core support.

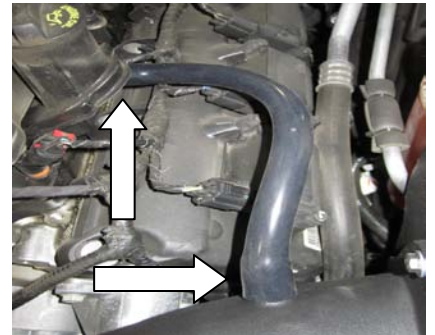

Attach the supplied breather hose and ATS harness. Reinstall the factory engine cover.



Remove the factory breather hose from the crankcase and air box. Remove the air box mounting bolt and air box.



Attach the hump hose to the filter adapter and tighten the clamp.

