



Equipped with AEM® Dryflow™ Filter
No Oil Required!

INSTALLATION INSTRUCTIONS

PART NUMBER: 22-463

1997-1999	TOYOTA	Tacoma	L4-2.7L	C.A.R.B. E.O. # D-392-18
1997-1999	TOYOTA	Tacoma	L4-2.4L	C.A.R.B. E.O. # D-392-18
1996-1999	TOYOTA	4 Runner	L4-2.7L	C.A.R.B. E.O. # D-392-21
1995-1996	TOYOTA	Tacoma	L4-2.7L	C.A.R.B. E.O. # D-392-21
1995-1996	TOYOTA	Tacoma	L4-2.4L	C.A.R.B. E.O. # D-392-21

* **NOTE:** Legal in California only for racing vehicles which may never be used upon a highway

PARTS LIST

Description	Qty.	Part Number
Element Parts Kit 3.00 X 5" Dry Ele.	1	21-203DK
Short Pipe	1	2-4631
Adapter, MAF	1	2-640
Hose, Adapter 2.75/3.00 X 3" Bl.	1	5-273
Hose, Silicone 3.00x3" Blk.	1	5-300
Hose; 5/8"ID X 20"L	1	5-7020
Hose; 3/8"ID X 12"L	1	5-1012
Grommet, 3/16"	1	784635
Grommet, 7/16"	1	784632
Mount, Rubber 1" X 6mm	1	1228599
Vacuum Cap, 3/8"	1	8-101
Connector, Plastic 1/8" Straight	1	8-103
Plug, Plastic 5/8"	1	8-102
Bracket, Support 22-463 TK/PC	1	32-3005
Bolt, Hex M6-1 X 25mm	4	1-2044
Washer, M6 X 12mm OD Zinc	4	1-3018
Washer, 6mm Soft Mount	1	559999
Nut, M6 Hex Serrated	1	444.460.04
1/2" Bnd. Hose Clamp,2.31-3.25"	1	9444
1/2" Bnd. Hose Clamp,2.56"-3.50"	3	9448
1/2" Bnd. Hose Clamp,2.90"-3.75"	1	9452

Read and understand these instructions BEFORE attempting to install this product. Failure to follow installation instructions and not using the provided hardware may damage the intake tube, throttle body and engine.

1. Preparing Vehicle

- a. Make sure vehicle is parked on level surface.
- b. Set parking brake.
- c. If engine has run in the past two hours, let it cool down.
- d. Disconnect negative battery terminal.
- e. Do not discard stock components after removal of the factory system.

2. Removal of stock system

- a. Reference the diagram labeled figure 1 on page 5. There is an air hose for the idle air control, a mass air flow meter and an air hose for the carbon canister (Fig. 4.1) and a vacuum sensing hose for the fuel pressure regulator (Fig. 4.2).
- b. **NOTE: Vehicles not equipped with IAT skip to step 2d.**
Unplug the MAF meter connector (Fig.1).
- c. On vehicles that are equipped with an IAT, remove it as shown. (Fig. 2)
- d. Loosen the inlet pipe hose clamp. (Fig. 3)
- e. Disconnect the inlet pipe from the air cleaner cap.
- f. Remove the air hose from the carbon canister to the air cleaner cap.
- g. Loosen the 4 clips, and remove the air cleaner cap together with the MAF meter.
- h. Separate the MAF and gasket from the air cleaner cap, by loosening the four 10 mm nuts.
- i. Separate the MAF sensor wire from the air cleaner hose. (Fig. 3)
- j. Loosen the air cleaner hose clamps and remove the air cleaner hose together with the resonator.
- k. On the stock inlet pipe, remove the following (Fig. 4)
 - i. Air hose for the idle air control.
 - ii. Vacuum sensing hose for the fuel pressure regulator.
 - iii. Wire retainer for engine wire.
- l. Remove the two bolts, hose clamp, and intake air connector.
- m. Loosen the three bolts that secure the lower air box. Remove the stock lower air box from the vehicle (Fig.5)

NOTE: It is not necessary to remove the stock resonator from inside the fender well.

3. Installation of AEM[®] intake system.

- a. When installing the intake system, do not completely tighten the hose clamps or mounting hardware until instructed to do so.
- b. Check to see that the inside of the AEM[®] inlet pipe and air filter are clean and free from any obstructions.
- c. Install the 2.75" side of a reducer coupler onto the throttle body using a No. 44 hose clamp.
- d. Install one No. 48 hose clamp onto the other end of the reducer coupler.
- e. Install the rubber grommet into the 0.25" hole in the AEM[®] inlet pipe, and install the supplied plastic nipple into the grommet. (Fig. 6)
- f. Slide the end nearest the breather hose nipples of the AEM[®] inlet pipe into the coupler on the throttle body.
- g. Mount the AEM[®] MAF adapter to the MAF using the gasket from the air cleaner cap, together with the mounting bracket using the four supplied M6 socket head bolts and washers, as shown. Do not tighten these bolts. (Fig. 7)

- h. Vehicles not equipped with IAT insert 5/8 plastic plug in hole on intake pipe. Proceed to step j)
- i. Vehicles equipped with IAT, install 5/8 rubber grommet to accommodate IAT sensor. (Fig. 8)
- j. Install a 3.0" coupler to the MAF, and secure it with a No. 48 clamp
- k. Install the AEM air filter on the MAF adapter, using a No. 48 clamp.
- l. Thread the supplied rubber mount into the factory threaded hole in the inner fender, as shown. (Fig. 9)
- m. Install the MAF/air filter assembly onto the AEM® inlet pipe, with the stud on the rubber mount in the slot of the MAF bracket. (Fig. 10)
- n. Use the supplied nylock nut and 6M washer to secure the bracket to the stud. Do not tighten.
- o. Replace the hose for the Idle Air Control (IAC) hose with the supplied 5/8" hose, and secure it with the factory spring clamps. (Fig. 11)
- p. Connect the factory Vacuum Sensing Hose for the fuel pressure regulator to the plastic nipple in the inlet pipe.
- q. Replace the air hose for the carbon canister with the supplied 3/8" hose.

4. Reassemble Vehicle

- a. **MAF Sensor:** Reconnect the wiring harness connector to the MAF sensor. Also ensure that the MAF sensor wire harness is secured away from the exhaust manifold.
- b. Position the inlet pipes for the best fitment. Be sure that the pipes or any other components do not contact any part of the vehicle. Tighten the rubber mount, all bolts, and hose clamps.
- c. Check for proper hood clearance. Re-adjust pipes if necessary and re-tighten them.
- d. Inspect the engine bay for any loose tools and check that all fasteners that were moved or removed are properly tightened.
- e. Reconnect negative battery terminals and start engine. Let the vehicle idle for 3 minutes. Perform a final inspection before driving the vehicle.

5. CARB Sticker Placement

- a. The C.A.R.B. exemption sticker, (attached), must be visible under the hood so that an emissions inspector can see it when the vehicle is required to be tested for emissions. California requires testing every two years, other states may vary.

6. Service and Maintenance

- a. It is recommended that you service your AEM® Dryflow™ filter every 20,000 miles for optimum performance. Use AEM Dryflow cleaning kit part # 21-110.
- b. Use aluminum polish to clean your polished AEM® intake tube.
- c. Use window cleaner to clean your powder coated AEM® intake tube. **(NOTE: DO NOT USE aluminum polish on powder coated AEM intake tubes).**

For technical inquiries e-mail us at sales@aemintakes.com or call us at 800.992.3000

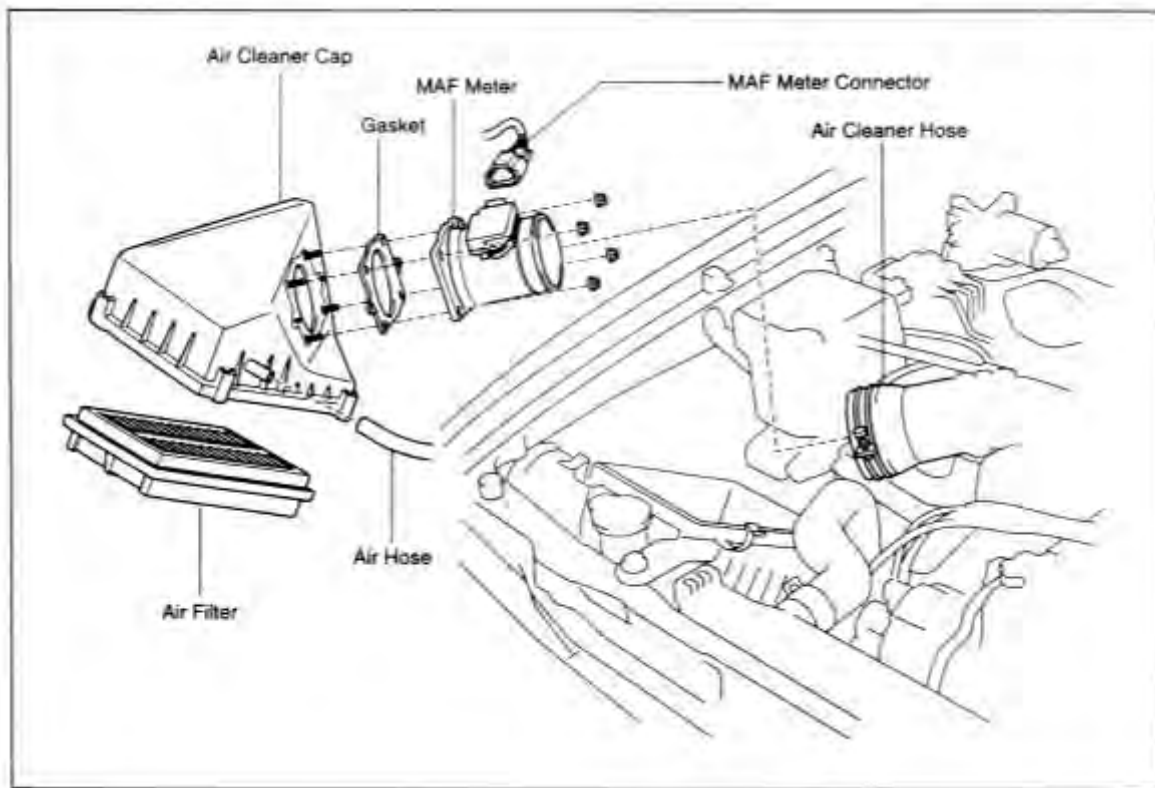

Fig. 1

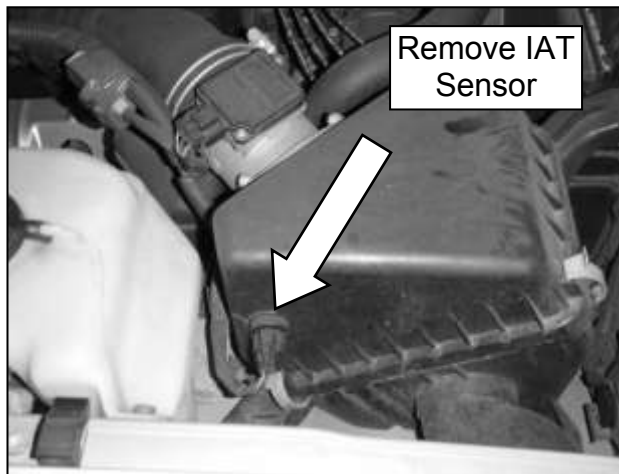

Fig. 2

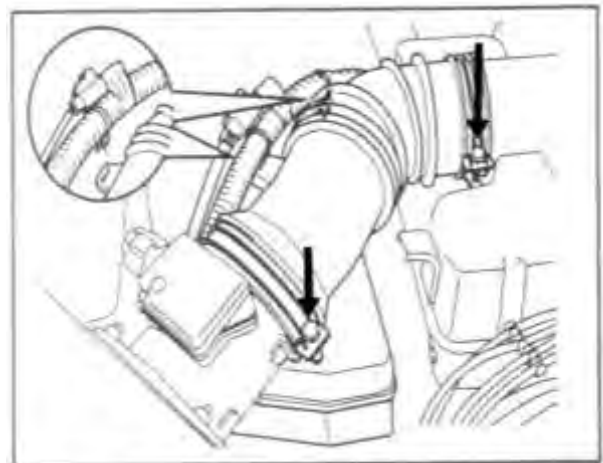

Fig. 3

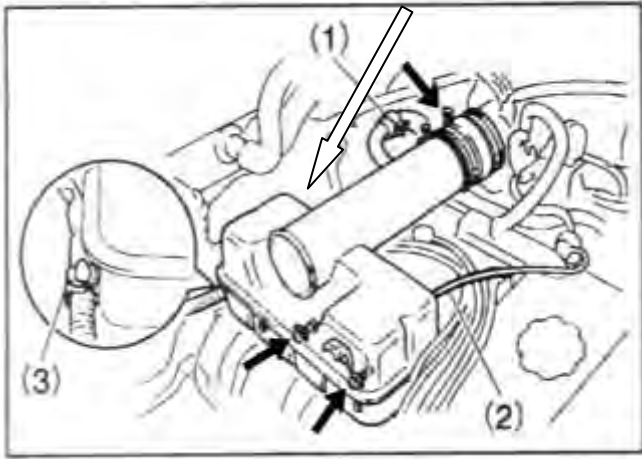

Fig. 4

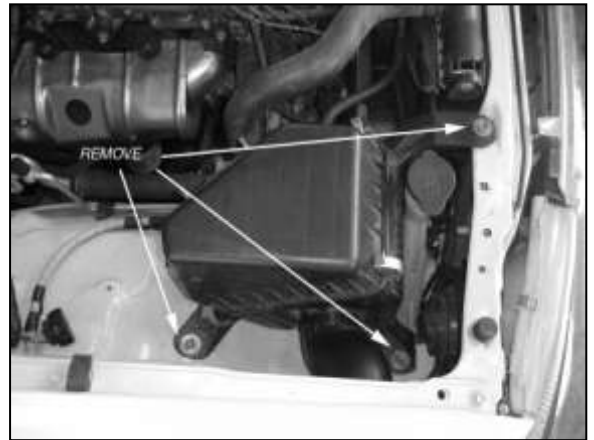

Fig. 5

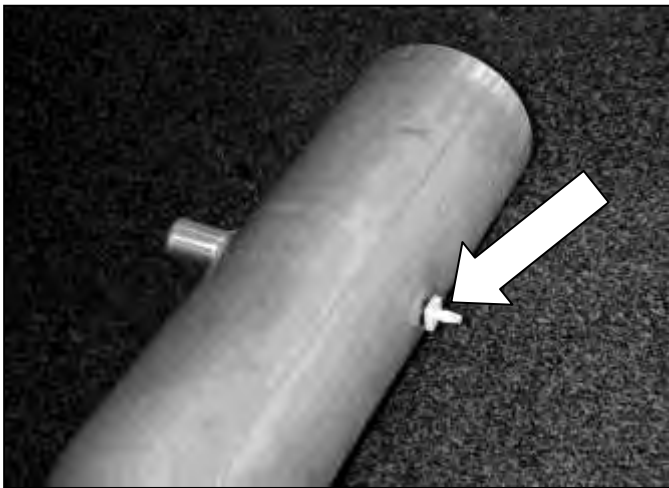

Fig. 6



Fig. 7

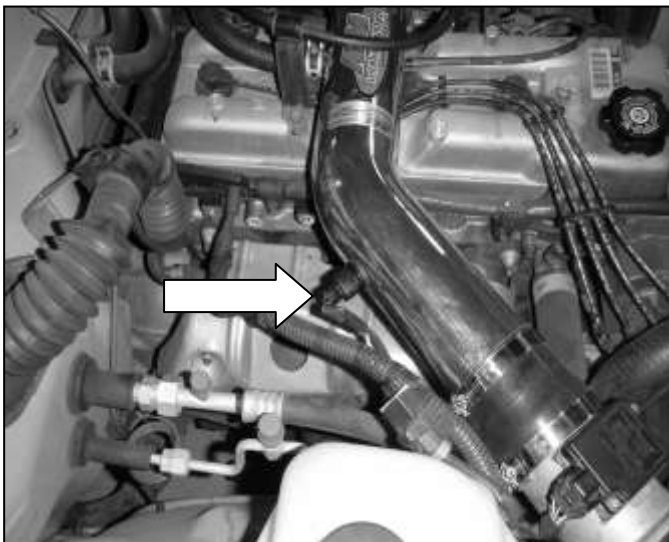

Fig. 8



Fig. 9

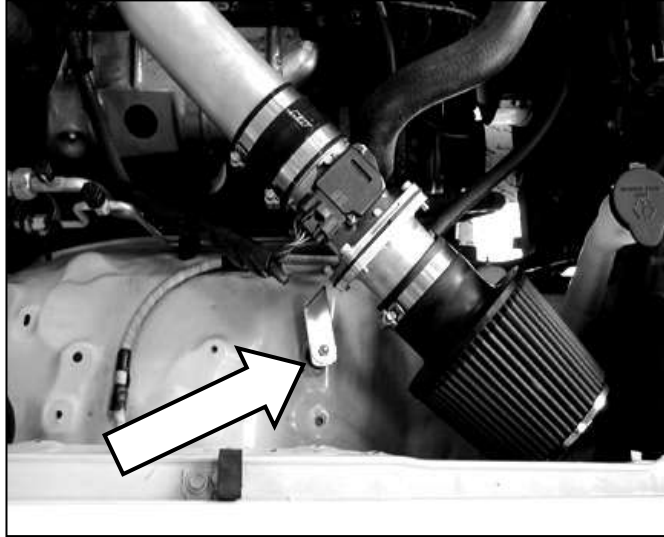

Fig. 10



Fig. 11

AEM Air Intake System Warranty Policy

AEM® warrants that its intake systems will last for the life of your vehicle. AEM will not honor this warranty due to mechanical damage (i.e. improper installation or fitment), damage from misuse, accidents or flying debris. AEM will not warrant its powder coating if the finish has been cleaned with a hydrocarbon-based solvent. The powder coating should only be cleaned with a mild soap and water solution. Proof of purchase of both the vehicle and AEM intake system is required for redemption of a warranty claim.

This warranty is limited to the repair or replacement of the AEM part. In no event shall this warranty exceed the original purchase price of the AEM part nor shall AEM be responsible for special, incidental or consequential damages or cost incurred due to the failure of this product. Warranty claims to AEM must be transportation prepaid and accompanied with dated proof of purchase. This warranty applies only to the original purchaser of product and is nontransferable. Improper use or installation, use for racing, accident, abuse, unauthorized repairs or alterations voids this warranty. AEM disclaims any liability for consequential damages due to breach of any written or implied warranty on all products manufactured by AEM. Warranty returns will only be accepted by AEM when accompanied by a valid Return Merchandise Authorization (RMA) number. Credit for defective products will be issued pending inspection. Product must be received by AEM within 30 days of the date RMA is issued.

If you have a warranty issue, please call (800) 992-3000 and our customer service department will assist you. A proof of purchase is required for all AEM warranty claims.