



Equipped with AEM® Dryflow™ Filter
No Oil Required!

INSTALLATION INSTRUCTIONS

PART NUMBER: 21-8029

2011-2010 CHEVROLET Camaro V8-6.2L SEE * NOTE

*** NOTE: Legal in California only for racing vehicles which may never be used upon a highway**

PARTS LIST

Description	Qty.	Part Number
A	1	21-2057DK
B	1	2-1418
C	1	9-0375
D	1	32-3070
E	1	5-400
F	1	8-312
G	1	21635-1
H	1	1228559
I	1	2-780
J	1	1-113
K	2	1-2105
L	1	1-2025
M	1	1-2030
N	2	08278
O	1	559960
P	1	1-3025
Q	4	444.460.04
R	3	9464

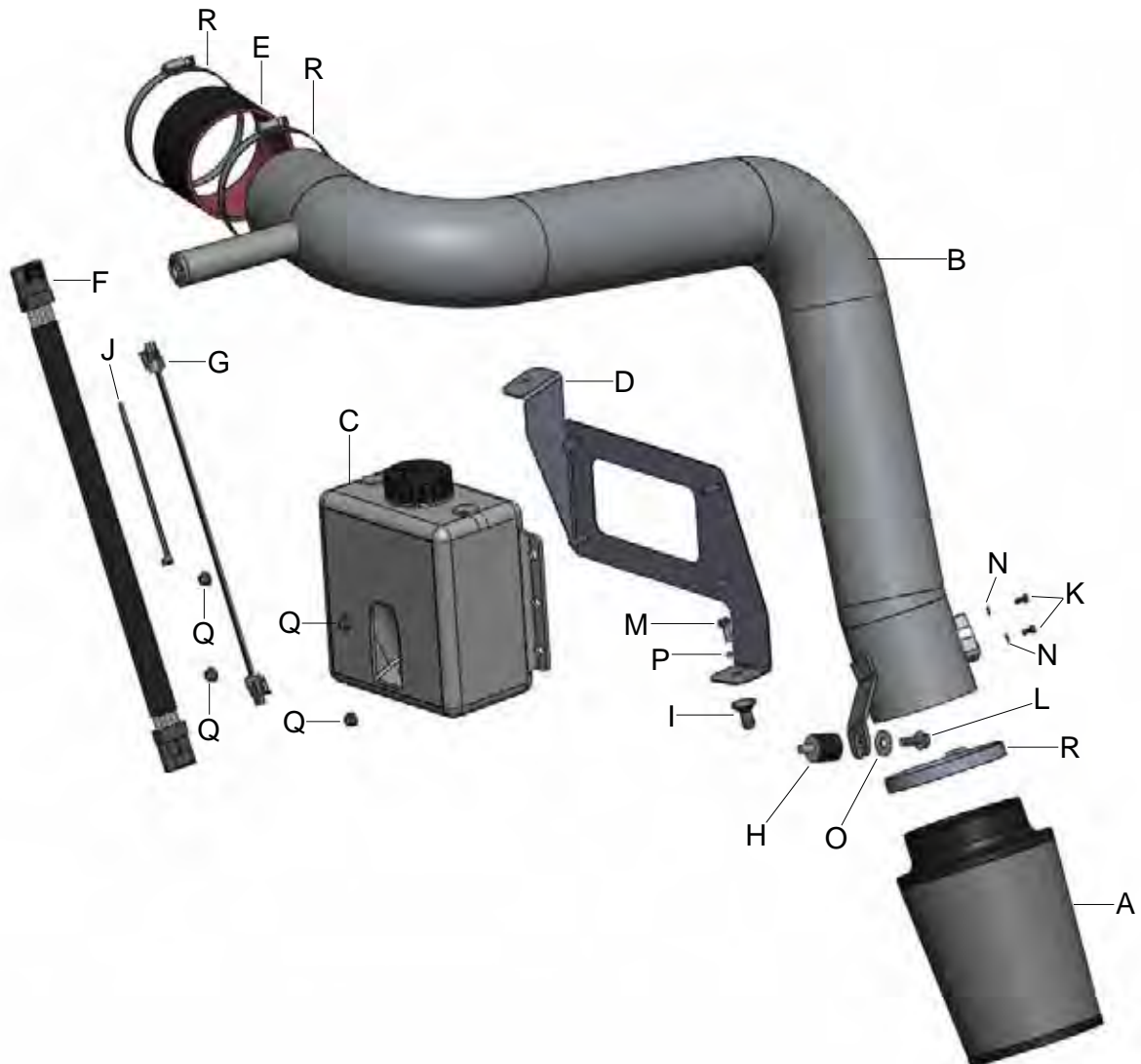

Read and understand these instructions **BEFORE** attempting to install this product. Failure to follow installation instructions and not using the provided hardware may damage the intake tube, throttle body and engine.

The AEM® intake system is a performance product that can be used safely during mild weather conditions. During harsh and inclement weather conditions, you must return your vehicle to stock OEM air box and intake tract configuration. Failure to follow these instructions will void your warranty.

• This kit installation requires wheel removal and re-installation. (Potential Safety Issue)

1. Preparing Vehicle

- a. Make sure vehicle is parked on level surface.
- b. Set parking brake.
- c. If engine has run in the past two hours, let it cool down.
- d. Disconnect the negative battery terminal located in the trunk of the vehicle.
- e. This intake system includes a replacement windshield washer system.
- f. Do not discard factory components after removal of the factory system.

2. Removal of factory system



a. Open the vehicle hood. Remove the engine cover. Start by removing the oil filler cap.



b. Pull up on the cover until it pops off its anchors. Remove it from the engine bay.



c. Replace the oil cap.



d. Locate the factory air intake system and unclip the 2 plastic tabs retaining air box lid.



e. Loosen the large hose clamp at the engine throttle body.



f. Disconnect the plastic breather pipe from the side of the factory intake resonator.



g. Disconnect the MAF sensor wiring harness by depressing the tab and pulling the connector.



h. Remove the upper intake tube and air box lid from the engine bay. Remember, you will need the factory MAF sensor for your new intake kit.



i. To remove the factory lower air housing, start by removing the two retaining nuts at the shock tower brackets and keep them for future use.



j. Now carefully pull up on the lower box until it pops free from its retaining anchor. Make sure the rubber anchor stays in the frame rail as you will need it to install your new kit. Store the factory air intake system components and filter.

3. Factory Washer Reservoir Removal

- a. Raise the front of the vehicle with a jack. Refer to your owner's manual for proper jack and jack stand placement to properly support vehicle. Support your vehicle using properly rated jack stands before wheel removal or while working under the vehicle.

NEVER WORK UNDER A VEHICLE WITHOUT USING JACK STANDS.



b. Remove the driver's side front wheel.



c. Remove the 3 lower Torx T20 retaining screws from the plastic fender well cover.



d. Locate and remove the retaining tab at the shock tower with a flat blade screwdriver as shown.



e. Now carefully pull the fender cover away from the fender lip to gain access to the factory washer reservoir.



f. Disconnect the washer pump cable at the pump connector.



g. Carefully disconnect the washer fluid hose at the pump nipple by rotating it back and forth as you pull. Either quickly install a plug using a small piece of washer hose and a bolt (as shown) or allow the reservoir to drain from the nipple into a bucket.



h. Pull the washer hose away from its retaining tabs in the reservoir. From the top of the engine bay, pull the hose up and out of the retaining loop in the reservoir and set it on top of the fender well.



i. Locate and remove the 3 mounting bolts on the washer bottle using a 13mm socket.



j. Lower the washer bottle and remove it from the vehicle. Drain the fluid into a clean bucket.

4. AEM® Windshield Washer Bottle Assembly



a. Remove the factory washer pump from the factory washer bottle by pulling it outward and then upward from the washer bottle, and then install the pump onto the 3-quart plastic washer bottle in your kit. Position the nipple as shown.



b. Attach the black mounting nipple onto the lower end of the bracket using the 15mm M6 bolt and lock washer provided and fully tighten.



c. Mount the washer bottle onto the large bracket using the (4) M6 nuts as shown and fully tighten.

5. Installation of AEM® intake system.

a. When installing the intake system, do not completely tighten the hose clamps or mounting hardware until instructed to do so.



b. Start under the vehicle by installing the M8 male/female insulated stud mount into the washer bottle mounting nut in the frame rail. Then partially install the M8 bolt and washer as shown.



c. In the engine bay, install the washer pump extension cable onto the factory cable as shown.



d. Install the MAF sensor extension harness onto the factory connector as shown.



e. Install the large straight coupler on the throttle body. Loosely install the 2 #64 hose clamps onto the coupler as shown.



f. Remove the factory MAF sensor from the factory intake by removing the two mounting bolts.



g. Install the MAF sensor onto the intake tube mounting pad using the black M4 Allen head machine screws (Qty. 2) and the small washers provided.



h. Now install the large intake tube with the MAF sensor into the engine bay. First, carefully lower the intake end of the tube with the mounting bracket down along the outside of the frame rail and onto the M8 bolt on the insulated mount. Take care not to snag the wiring harness in that area.



i. Next, insert the upper end of the tube loosely into the coupler at the throttle body.



j. Connect the factory breather pipe to the large nipple on the side of the new intake tube.



k. Bring the washer bottle assembly to the engine bay. Connect the factory washer fluid hose to the nipple on the washer pump. Connect the washer pump extension harness to the washer pump.



l. Now mount the washer bottle assembly behind the intake tube. First, drop the upper bracket mounting hole over the factory stud in shock tower.



m. Next, push the lower mounting nipple into the factory rubber anchor in the frame rail until it pops in. Be sure not to trap any wiring harnesses or the washer hose under the new washer bottle or bracket.



n. Carefully route the washer fluid hose and pump harness away from the engine.



o. Now fasten the washer bracket assembly with the factory retaining nut at the upper shock tower bracket and fully tighten.



p. Pass the MAF sensor extension harness underneath the upper radiator hose as shown and drop the connector down toward the open end of the intake tube.



q. Underneath the vehicle, connect the MAF sensor harness to the MAF sensor in the intake tube.



r. Now secure the intake tube bracket to the insulated rubber mount using the M8 bolt and washer provided. Be sure the intake tube is not contacting the washer bottle bracket and then fully tighten the bolt.



s. Use the 6" zip tie to retain the washer fluid hose and extension harness as shown. Be sure that the washer hose is not rubbing the edge of the frame rail.



t. Next, install the Dryflow™ high-performance air filter to the intake tube with a hose clamp as shown and fully tighten.



u. In the engine bay, adjust the intake tube so there is about 1" of clearance between the tube and the corner of the washer bottle bracket. Now fully tighten the 2 hose clamps at the throttle body.



Factory air box system installed



AEM® intake system installed

6. Reassemble Vehicle

- a. **Fender Liner:** Re-install the plastic mounting clip and 3 Torx screws to secure the plastic fender liner.
- b. **Wheel:** Install the driver's side wheel using the factory torque specification (see owner's manual).
- c. **Engine Cover:** Remove the oil cap, mount the engine cover on its rubber anchors, and replace the oil cap.
- d. **Washer Bottle:** Fill the new 3 Qt. washer bottle with windshield washer fluid.
- e. Position the inlet pipes for the best fitment. Be sure that the pipes or any other components do not contact any part of the vehicle. Tighten the rubber mount, all bolts, and hose clamps.
- f. Check for proper hood clearance. Re-adjust pipes if necessary and re-tighten them.
- g. Inspect the engine bay for any loose tools and check that all fasteners that were moved or removed are properly tightened.
- h. Reconnect negative battery terminal in the trunk of the vehicle and start engine. Let the vehicle idle for 3 minutes. Perform a final inspection before driving the vehicle.
- i. Test the windshield washer system. It may take a few seconds to refill the stock pump and hose with fluid.

7. Service and Maintenance

- a. It is recommended that you service your AEM® Dryflow™ filter every 20,000 miles for optimum performance. Use AEM Dryflow cleaning kit part # 21-110.
- b. Use aluminum polish to clean your polished AEM® intake tube.
- c. Use window cleaner to clean your powder coated AEM® intake tube. **(NOTE: DO NOT USE aluminum polish on powder coated AEM intake tubes).**

For technical inquiries
e-mail us at
sales@aemintakes.com
or
call us at
800.992.3000

AEM Air Intake System Warranty Policy

AEM® warrants that its intake systems will last for the life of your vehicle. AEM will not honor this warranty due to mechanical damage (i.e. improper installation or fitment), damage from misuse, accidents or flying debris. AEM will not warrant its powder coating if the finish has been cleaned with a hydrocarbon-based solvent. The powder coating should only be cleaned with a mild soap and water solution. Proof of purchase of both the vehicle and AEM intake system is required for redemption of a warranty claim.

This warranty is limited to the repair or replacement of the AEM part. In no event shall this warranty exceed the original purchase price of the AEM part nor shall AEM be responsible for special, incidental or consequential damages or cost incurred due to the failure of this product. Warranty claims to AEM must be transportation prepaid and accompanied with dated proof of purchase. This warranty applies only to the original purchaser of product and is nontransferable. Improper use or installation, use for racing, accident, abuse, unauthorized repairs or alterations voids this warranty. AEM disclaims any liability for consequential damages due to breach of any written or implied warranty on all products manufactured by AEM. Warranty returns will only be accepted by AEM when accompanied by a valid Return Merchandise Authorization (RMA) number. Credit for defective products will be issued pending inspection. Product must be received by AEM within 30 days of the date RMA is issued.

If you have a warranty issue, please call (800) 992-3000 and our customer service department will assist you. A proof of purchase is required for all AEM warranty claims.