



Load Stop Installation Instructions

Package Contents:

- (4) Load Stops
- (4) T-bolts
- (4) Nylon washers
- (4) Daisy Dials
- (2) Tension Lock Straps

1.

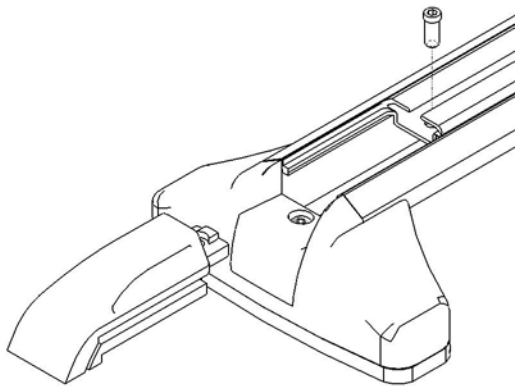

Remove the end cap from the crossbar bar by loosening the narrow shoulder hex screw.

2.

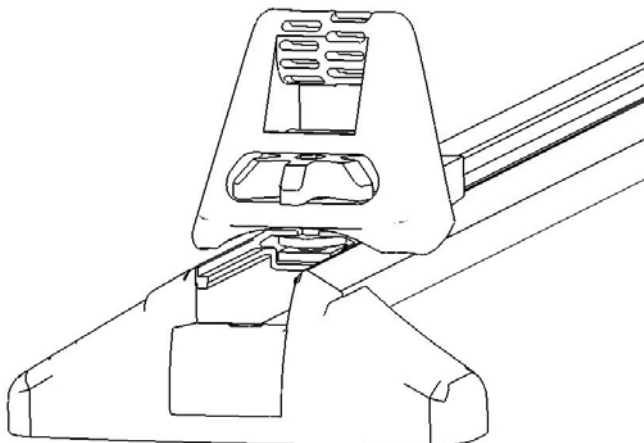

Align the tab on the front of the load stop so that it slides into the channel. Loosen the daisy dial on the load stop so that the nylon washer rests inside the channel on the crossbar.

3.

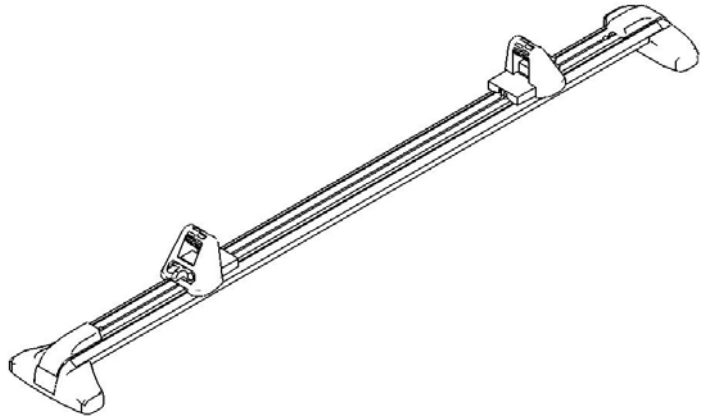

Slide two load stops into the crossbar. The load stops should be orientated such that they face each other. Replace end cap after load stops are in place.

Position the load (ladders, canoe, boat, etc.) between the load stops. Be certain the load stops are snug against the load. Canoes and boats should be upside down.

Turn the daisy dial clockwise to tighten the load stop against the crossbar. Tighten dials until load stops are snug. Do not over tighten.

4.

To secure, thread free end of strap through the load stop, bring both ends over the load (ladders, canoe, boat, etc.), and thread through the opposite load stop.

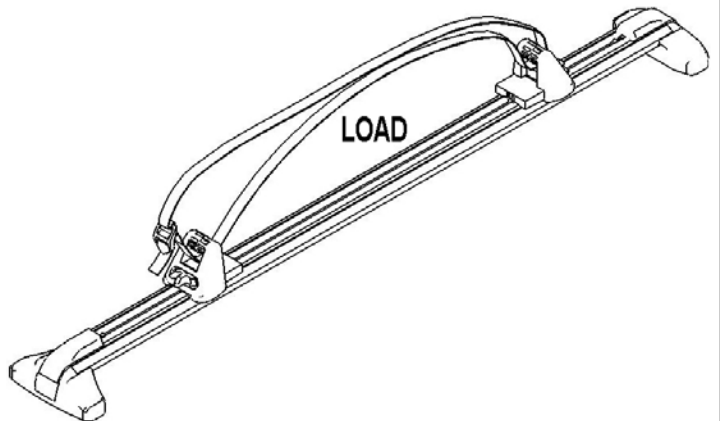

5.

Thread end of strap through the buckle as shown below

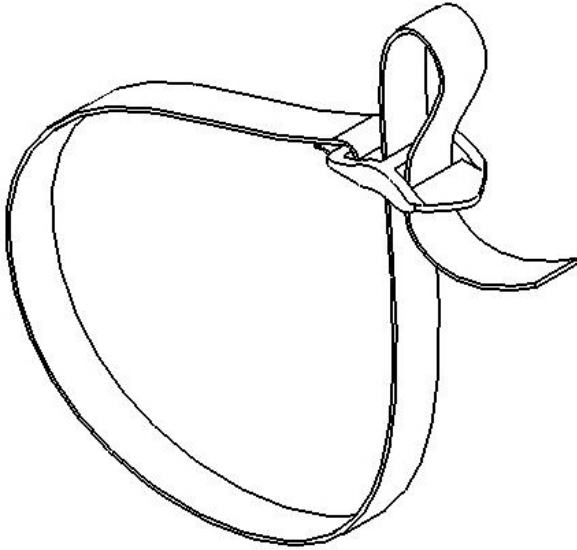

6.

Pull strap tight and knot all straps against buckle.

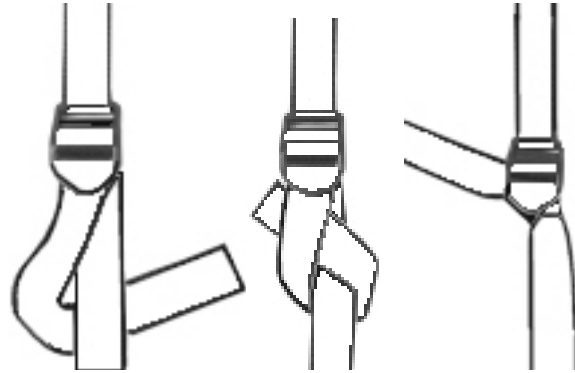

7.

Check your installation. Be certain:

Load is secured with tie down straps to both crossbars and from front to rear of load to bumper area.

Daisy dials are tight and load stops are secure to crossbar.

Load is evenly distributed on crossbars. For maximum weight limitations, follow recommendations of vehicle manufacture and rack manufacturer.

The entire system including the attachment of crossbars to vehicle is stable and secure.

PRO RAC GUIDELINES

Please review the instructions and warranty carefully. Assembly and installation are the purchaser's responsibility and beyond ProRac's control. Therefore, ProRac exclusively limits its warranty to the repair or replacement of a defective ProRac product for up to three years from retail purchase. Warranty excludes damage to your vehicle, cargo, or any person or property during assembly, installation, and use.

- ◆ Do not carry more than 150 pounds (68KG) of combined cargo and accessories on ProRac crossbars. ProRac crossbars do not increase gutter or roof strength. ProRac cannot warranty loads that exceed this limit.
- ◆ Do not use ProRac crossbars and accessories for purposes other than those for which they were designed. Do not exceed their carrying capacity. Failure to follow these guidelines or the product instructions will void the warranty.
- ◆ Make sure all knobs, bolts, screws, straps, and locks are firmly attached, tightened, and locked before every trip. All fasteners must be periodically inspected for signs of wear, corrosion, and fatigue. Check your load at stops during long trips to ensure continued fastening security.
- ◆ Check all local and state laws governing projection of objects beyond the width and length of vehicle. Be aware of the width and height of your cargo since low-clearance branches, bridges, and parking garages can affect the load. Never drive with any lock, knob, or rack in an open or unlocked position. All long loads such as, but not limited to, sailboards, surfboards, kayaks, canoes, and lumber must be tied down front and rear to the bumpers or tow hooks of the vehicle.
- ◆ Remove your rack and accessories when they are not in use and before entering automatic car washes.
- ◆ All locks must be turned and moved periodically to ensure smooth operation. Use graphite or similar dry lubricant. Locks are designed to deter vandalism and theft. Remove valuable gear if your vehicle is unattended. Replacement keys are available only through your ProRac dealer.
- ◆ All cargo will affect the vehicle's driving behavior. For your safety, adapt your speed to the conditions of the road and load being carried. Obey all posted speed limits and traffic cautions.
- ◆ Due to their wind resistance, do not carry disks or wheels with covers on the ProRac bike carrier.
- ◆ Consult your ProRac dealer if you have questions regarding the operation and limits of ProRac products. Review all instructions and warranty information carefully.

© 2005 ProRac Systems, Inc.

FGAT953-IS
Revised 5-16-05

ProRac Systems Inc.
7109 31st Avenue North
Minneapolis, MN 55427-2848

Toll Free: 1-800-217-7133
Phone: 763-546-5620
Fax: 763-546-0933
WWW.PRORAC.COM