



Equipped with AEM® Dryflow™ Filter
No Oil Required!

INSTALLATION INSTRUCTIONS

PART NUMBER: 21-9211

2003-2006	DODGE	Ram 2500 Pickup L6-5.9L DSL	C.A.R.B. E.O. # D-670
2003-2006	DODGE	Ram 3500 Pickup L6-5.9L DSL	C.A.R.B. E.O. # D-670

* **NOTE: Legal in California only for racing vehicles which may never be used upon a highway**

PARTS LIST

Description	Qty.	Part Number
A	1	21-2259DK
B	1	2-82111
C	1	20-8211
D	1	5-490
E	1	8-4012
F	1	5-2259
G	1	8-164
H	2	1228560
I	1	8-3020
J	3	1-127
K	1	32-3048
L	2	1-2097
M	3	1-2038
N	2	08160
O	4	1-3027
P	4	559960
Q	4	444.460.08
R	3	444.460.04
S	3	9464

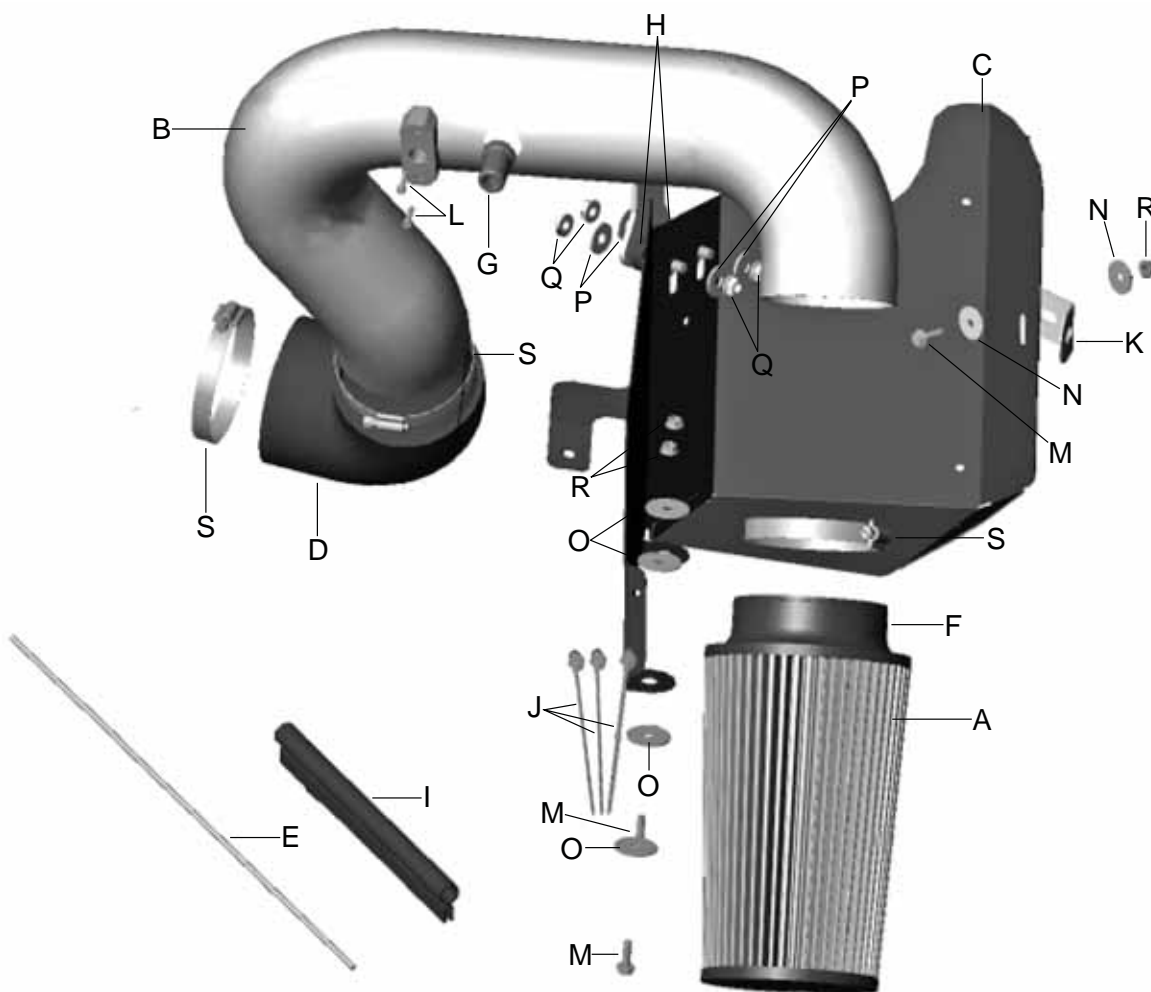

Read and understand these instructions **BEFORE** attempting to install this product. Failure to follow installation instructions and not using the provided hardware may damage the intake tube, throttle body and engine.

1. Preparing Vehicle

- a. Make sure vehicle is parked on level surface.
- b. Set parking brake.
- c. If engine has run in the past two hours, let it cool down.
- d. Disconnect negative battery terminal.
- e. Do not discard stock components after removal of the factory system.

2. Removal of stock system



a. Stock airbox system installed. Unplug the wiring harness from the inlet air temperature (IAT) sensor.



b. Loosen the hose clamps securing the flexible inlet hose between the turbo inlet and the air filter housing. Remove the hose.



c. Remove the nut securing the front of the air filter housing to the chassis. Lift up on the air filter housing and remove it from the engine bay.



d. Remove the grommets from the plastic battery-tray. Remove the bolt securing the battery tray to the fender.



e. Remove the bolt securing the radiator shroud to the radiator as shown.
NOTE: 2003-2004.5 models have a different radiator than the 04.5+ models. May differ from picture shown.



f. Remove the factory air filter restriction gauge and the IAT sensor from the stock air filter housing.

3. Installation of AEM® intake system.

a. When installing the intake system, do not completely tighten the hose clamps or mounting hardware until instructed to do so.



b. Factory airbox system removed.

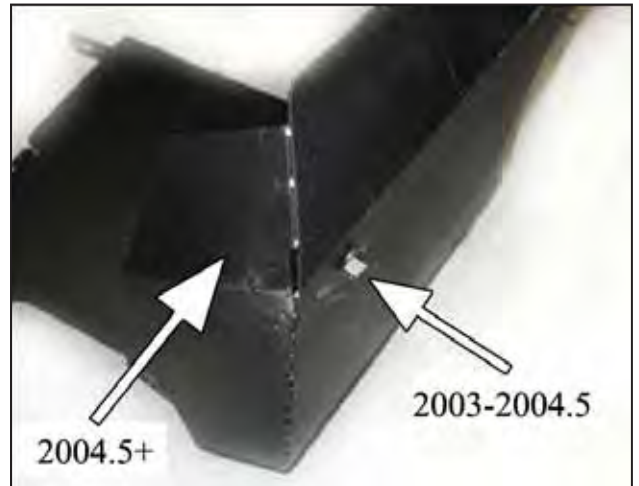

c. Install one supplied tree mount zip tie into the hole on the heat shield bottom as shown. On earlier models (03-04.5), install the lower zip-tie in the hole on the right side of the heat shield.



d. Install the remaining two zip ties into the two remaining holes in the heat shield.



e. Install the supplied rubber edge trim onto the top edge of the heat shield.



f. Install the two rubber mounts into the two holes on the heat shield using the supplied M8 washers and nuts. Do not tighten the nuts.



g. Install the front heat shield mount using the supplied M6 nut, bolt and two smaller flat washers. The bracket will need to align with the bolt removed in step 2e.



h. Install the heat shield by aligning the two holes on the bottom with the two larger holes on the battery tray. Secure using the supplied M6 bolts, nuts, and flat washers.



i. Install the bolt removed in step 2e to secure the front heat shield mount.



j. Align the small mounting tab of the heat shield with the hole exposed in step 2d. Install the bolt, securing the heat shield to the top of the fender as shown.



k. Use the installed zip-ties to secure the battery cable, washer bottle hose, and AC hose to the heat shield. Trim excess plastic.



l. Install the IAT sensor into the intake pipe using the two supplied bolts.



m. Install the nipple onto the intake pipe (use soapy water to aid installation if necessary). Place the nipple onto the pipe at an angle and rotate it until the groove engages the pipe. Install the previously removed air filter restriction gauge into the nipple.



n. Secure the coupler to the turbocharger using a #64 hose clamp, but do not completely tighten the clamp.

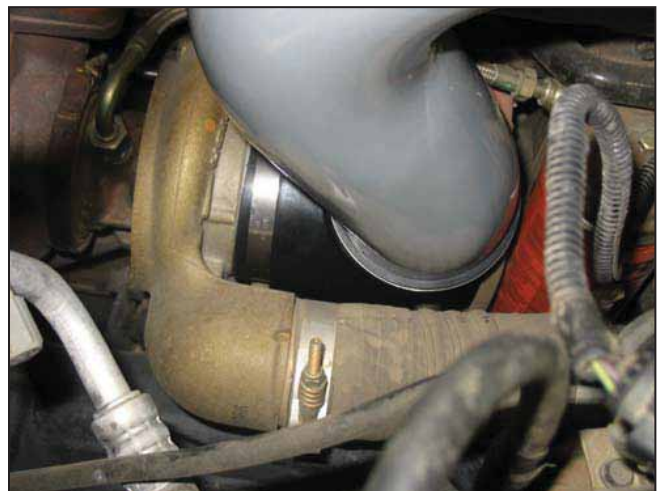

o. Install the intake pipe by sliding the pipe into the elbow installed on the turbo inlet.



p. Align the mounting bracket of the intake pipe with the two rubber mounts on the heat shield. Install the remaining M8 washers and nuts to secure.



q. Plug the IAT wiring harness into the IAT sensor as shown. Ensure that the harness does not contact the exhaust manifold.



r. Install the supplied air filter adapter by stretching it over the end of the intake pipe.



s. Slide the hose clamp onto the air filter's neck and attach the air filter assembly onto the filter adapter. Ensure the air filter is completely seated onto the adapter and the hose clamp is aligned with the filter adapter's lip. Once the hose clamp is properly aligned, secure the hose clamp, ensuring the filter neck's tabs compress and engage the filter adapter. Ensure the air filter does not make contact with any part of the vehicle and has adequate clearance.



t. Ensure the intake pipe is centered in the heat shield hole. Once proper fitment is achieved, tighten the nuts on the bracket and the hose clamps on the intake pipe and turbo.



Factory airbox system installed



AEM® intake system installed

4. Reassemble Vehicle

- a. Position the inlet pipes for the best fitment. Be sure that the pipes or any other components do not contact any part of the vehicle. Tighten the rubber mount, all bolts, and hose clamps.
- b. Check for proper hood clearance. Re-adjust pipes if necessary and re-tighten them.
- c. Inspect the engine bay for any loose tools and check that all fasteners that were moved or removed are properly tightened.
- d. Reconnect negative battery terminals and start engine. Let the vehicle idle for 3 minutes. Perform a final inspection before driving the vehicle.

5. CARB Sticker Placement

- a. The C.A.R.B. exemption sticker, (attached), must be visible under the hood so that an emissions inspector can see it when the vehicle is required to be tested for emissions. California requires testing every two years, other states may vary.

6. Service and Maintenance

- a. It is recommended that you service your AEM® Dryflow™ filter every 20,000 miles for optimum performance. Use AEM Dryflow cleaning kit part # 21-110.
- b. Use aluminum polish to clean your polished AEM® intake tube.
- c. Use window cleaner to clean your powder coated AEM® intake tube. **(NOTE: DO NOT USE aluminum polish on powder coated AEM intake tubes)**

For technical inquiries
e-mail us at
sales@aemintakes.com
or
call us at
800.992.3000

AEM Air Intake System Warranty Policy

AEM® warrants that its intake systems will last for the life of your vehicle. AEM will not honor this warranty due to mechanical damage (i.e. improper installation or fitment), damage from misuse, accidents or flying debris. AEM will not warrant its powder coating if the finish has been cleaned with a hydrocarbon-based solvent. The powder coating should only be cleaned with a mild soap and water solution. Proof of purchase of both the vehicle and AEM intake system is required for redemption of a warranty claim.

This warranty is limited to the repair or replacement of the AEM part. In no event shall this warranty exceed the original purchase price of the AEM part nor shall AEM be responsible for special, incidental or consequential damages or cost incurred due to the failure of this product. Warranty claims to AEM must be transportation prepaid and accompanied with dated proof of purchase. This warranty applies only to the original purchaser of product and is nontransferable. Improper use or installation, use for racing, accident, abuse, unauthorized repairs or alterations voids this warranty. AEM disclaims any liability for consequential damages due to breach of any written or implied warranty on all products manufactured by AEM. Warranty returns will only be accepted by AEM when accompanied by a valid Return Merchandise Authorization (RMA) number. Credit for defective products will be issued pending inspection. Product must be received by AEM within 30 days of the date RMA is issued.

If you have a warranty issue, please call (800) 992-3000 and our customer service department will assist you. A proof of purchase is required for all AEM warranty claims.