



Equipped with AEM® Dryflow™ Filter
No Oil Required!

INSTALLATION INSTRUCTIONS

PART NUMBER: 21-8309

2004 – 2006 JEEP Liberty V6–3.7L C.A.R.B. E.O. # D-670

* NOTE: Legal in California only for racing vehicles which may never be used upon a highway

PARTS LIST

	Description	Qty.	Part Number
A	Inlet Pipe	1	2-83092
B	Hose, Adapter 3.00/3.25x3 Nipple	1	5-323-J
C	1/2" Bnd. Hose Clamp, 2.56"-3.50"	1	9448
D	1/2" Bnd. Hose Clamp, 2.90"-3.75"	2	9452
E	Air Filter Assy. 3.00 X 9" Dry Ele.	1	21-2039DK
F	Bolt, Hex 1/4-20 X 1 3/4	1	1-2072
G	Nut, 1/4-20 Nylock	1	1-2074
H	Nut, 1/4-20	1	1-2073
I	Stand, Aluminum	1	2-670
J	Washer, 6mm Soft Mount	7	08160
K	Heat Shield	1	20-8309
L	Nut, M6 Hex Serrated	5	444.460.04
M	Edge Trim, 8"	1	8-4008
N	Mount, Rubber 1" X 6mm	1	1228599
O	Hose Clamp, 1"	1	99024.032
P	Edge Trim, 12"	1	8-4012

Read and understand these instructions BEFORE attempting to install this product. Failure to follow installation instructions and not using the provided hardware may damage the intake tube, throttle body and engine.

1. Preparing Vehicle

- a. Make sure vehicle is parked on level surface.
- b. Set parking brake.
- c. If engine has run in the past two hours, let it cool down.
- d. Disconnect negative battery terminal.
- e. Do not discard stock components after removal of the factory system.

2. Removal of stock system

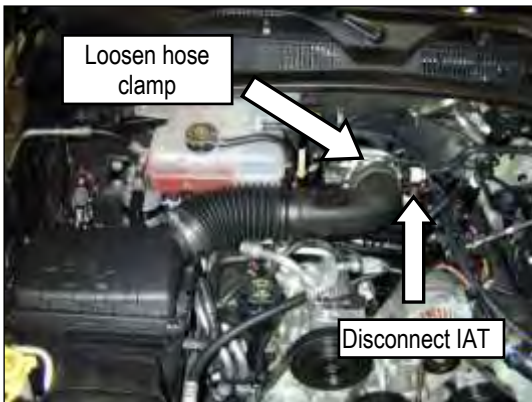

a. Loosen the hose clamp at the throttle body. Disconnect the IAT (Inlet Air Temperature) sensor harness connector. Push out the clip on the IAT to release.



b. Disconnect the crankcase breather hose from the airbox. Remove the airbox by pulling straight up.

3. Installation of AEM® intake system.

- a. When installing the intake system, do not completely tighten the hose clamps or mounting hardware until instructed to do so.

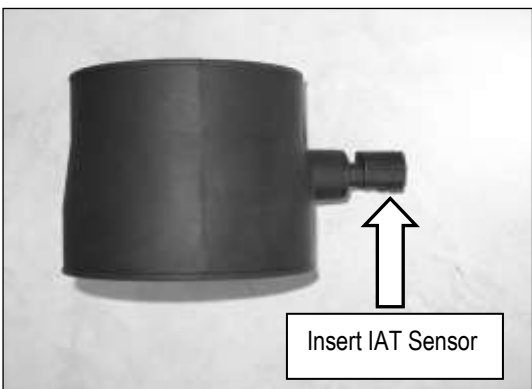

b. Remove the IAT sensor from the stock inlet pipe. Reinsert the sensor into the new throttle body coupler as shown.

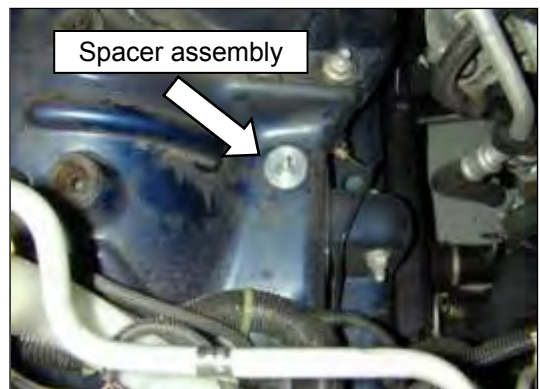

c. Mount the spacer assembly in the lower rubber mount left by the bottom of the airbox. The spacer assembly consists of the following: bolt, washer, spacers and nuts. Refer to the diagram on next page.

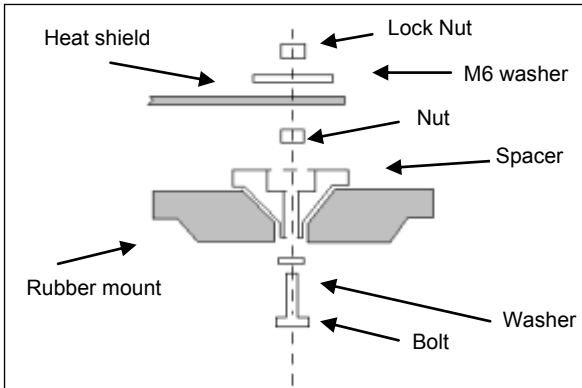

d. Diagram of the spacer assembly.

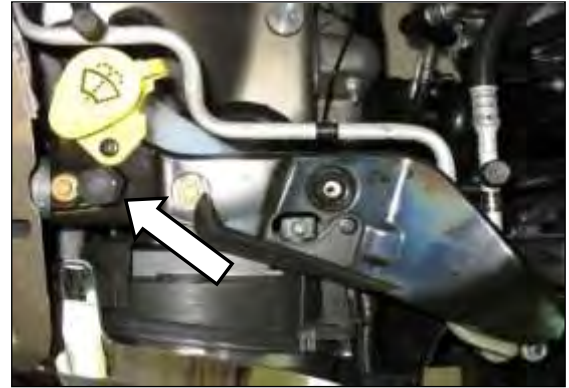

e. Remove the bolt, it will be reused in a later step.



f. Attach the coupler as shown. Secure with #52 hose clamp on the throttle body and #48 on the open end. Reattach the IAT sensor harness to the IAT sensor.



g. Loosen and remove the mounting nut. This nut will be reused if your vehicle has cruise control. If your vehicle is not equipped with cruise control, then use the provided M6 nut.



h. Insert the heat shield. Secure with the provided washers and nuts. Check for factory installed hardware. If studs are secured with nuts already, remove first. Use care to avoid damaging the vacuum hoses or the wire harness.



i. Attach the rubber mount and secure with 8mm washer and nut.



j. Insert the inlet pipe as shown. Align the mounting bracket with the rubber mount on the heat shield.



k. Secure the inlet pipe bracket to the rubber mount with a 8mm washer and a nut.



l. Rotate the breather hose 90° clockwise. Reattach the crankcase breather hose. Secure with the provided hose clamp.



m. Attach the air filter and secure with a hose clamp once properly aligned. Attach the rubber edge trim to the top of the heat shield as shown.



AEM® intake system installed

4. Reassemble Vehicle

- a. Position the inlet pipes for the best fitment. Be sure that the pipes or any other components do not contact any part of the vehicle. Tighten the rubber mount, all bolts, and hose clamps.
- b. Check for proper hood clearance. Re-adjust pipes if necessary and re-tighten them.
- c. Inspect the engine bay for any loose tools and check that all fasteners that were moved or removed are properly tightened.
- d. Reconnect negative battery terminals and start engine. Let the vehicle idle for 3 minutes. Perform a final inspection before driving the vehicle.

5. CARB Sticker Placement

- a. The C.A.R.B. exemption sticker, (attached), must be visible under the hood so that an emissions inspector can see it when the vehicle is required to be tested for emissions. California requires testing every two years, other states may vary.

6. Service and Maintenance

- a. It is recommended that you service your AEM® Dryflow™ filter every 20,000 miles for optimum performance. Use AEM Dryflow cleaning kit part # 21-110.
- b. Use aluminum polish to clean your polished AEM intake tube.
- c. Use window cleaner to clean your powder coated AEM intake tube. **(NOTE: DO NOT USE aluminum polish on powder coated AEM intake tubes)**

For technical inquiries e-mail us at sales@aemintakes.com or call us at 800.992.3000

AEM Air Intake System Warranty Policy

AEM® warrants that its intake systems will last for the life of your vehicle. AEM will not honor this warranty due to mechanical damage (i.e. improper installation or fitment), damage from misuse, accidents or flying debris. AEM will not warrant its powder coating if the finish has been cleaned with a hydrocarbon-based solvent. The powder coating should only be cleaned with a mild soap and water solution. Proof of purchase of both the vehicle and AEM intake system is required for redemption of a warranty claim.

This warranty is limited to the repair or replacement of the AEM part. In no event shall this warranty exceed the original purchase price of the AEM part nor shall AEM be responsible for special, incidental or consequential damages or cost incurred due to the failure of this product. Warranty claims to AEM must be transportation prepaid and accompanied with dated proof of purchase. This warranty applies only to the original purchaser of product and is nontransferable. Improper use or installation, use for racing, accident, abuse, unauthorized repairs or alterations voids this warranty. AEM disclaims any liability for consequential damages due to breach of any written or implied warranty on all products manufactured by AEM. Warranty returns will only be accepted by AEM when accompanied by a valid Return Merchandise Authorization (RMA) number. Credit for defective products will be issued pending inspection. Product must be received by AEM within 30 days of the date RMA is issued.

If you have a warranty issue, please call (800) 992-3000 and our customer service department will assist you. A proof of purchase is required for all AEM warranty claims.