



LEGAL IN CALIFORNIA ONLY FOR RACING VEHICLES WHICH MAY NEVER BE USED, REGISTERED OR LICENSED FOR USE UPON A HIGHWAY. See knfilters.com for CARB status on each part for a specific vehicle

INSTALLATION INSTRUCTIONS

77-9035KP
TOYOTA
2010-2015 Tundra
V8-4.6L

NOTE: This kit was not designed to fit vehicles with a body lift.

TOOLS NEEDED:

- Ratchet
- Extension
- 13mm Socket
- 10mm Socket
- Flat Blade Screwdriver
- Phillips Screwdriver
- 10mm Wrench
- Pliers
- 5/8" Wrench
- 9/16" Wrench
- 3mm Allen Wrench

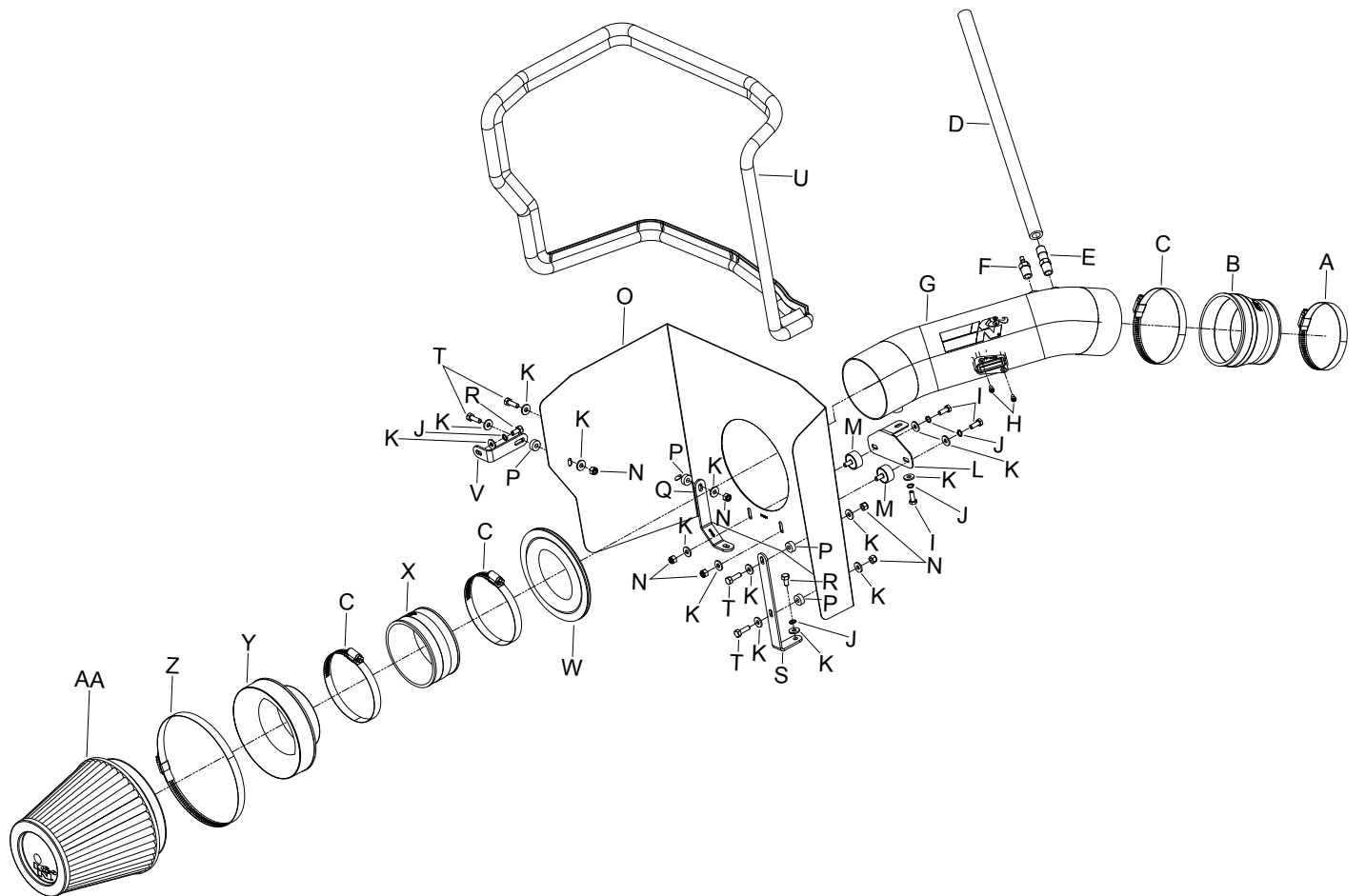

PARTS LIST:

Description	Qty.	Part #	Description	Qty.	Part #	Description	Qty.	Part #
A Hose Clamp #56	1	08620	J Washer; 1/4" Lock, ZN	5	08198	S Bracket; 57-1513, L-Bend, FIN., TB/PC	1	070902
B Hose; 4" To 3-1/2" ID X 3"L TPRD Molded	1	08050	K Washer; 1/4" ID X 5/8" OD- SAE	15	08275	T Bolt; M6 X 1.00" X 20MM HEX, SS	4	07795
C Hose Clamp #64 Stainless	3	08645	L Bracket; "L", STL, 63-9035, TB/PC	1	083152	U Edge Trim (75")	1	102460
D Hose; 1/2" ID X 17"L	1	08177	M Stud; Rubber MNT, M/F, 1/2"L X 1"W	2	070228	V Bracket; 57-3017, "L", FIN., TB/PC	1	070742
E Vent; STRT 1/2" Hose, 1/4" NPT, PLAS	1	080022	N Nut; 6MM Nylock, Hexhead, SS	6	07512	W Edge Trim; 3/4" Bulb, Top Loc, 20"L	1	102494
F Vent; STRT, 3/16 Barbed 1/4" NPT, Nylon	1	080021	O Heat Shield	1	07653-1	X Hose; 4" ID X 2" L Molded	1	08625
G Tube; 4"OD X 16"L,AL, 77-9035	1	27490KP	P Spacer .625" OD X .250" ID X .250"L	4	06555	Y Adaptor; 57-3058 #454	1	27300
H Bolt; M4 - 0.07 8MM, A/H Cap, SS	2	07733	Q Bracket; 63-1088, Mild STL, TB/PC	1	07190	Z Hose Clamp # 104	1	08697
I Bolt; 6MM-1.00 X 16MM, SS	3	07812	R Bolt; M6 X 1.00 X 12 MM, Hexhead, SS	2	07727	AA Air Filter	1	RF-1042XD

NOTE: FAILURE TO FOLLOW INSTALLATION INSTRUCTIONS AND NOT USING THE PROVIDED HARDWARE MAY DAMAGE THE INTAKE TUBE, THROTTLE BODY AND ENGINE.

TO START:

1. Turn off the ignition and disconnect the negative battery cable.
NOTE: Disconnecting the negative battery cable erases pre-programmed electronic memories. Write down all memory settings before disconnecting the negative battery cable. Some radios will require an anti-theft code to be entered after the battery is reconnected. The anti-theft code is typically supplied with your owner's manual. In the event your vehicles' anti-theft code cannot be recovered, contact an authorized dealership to obtain your vehicles anti-theft code.



2. Lift up the engine cover to dislodge it from the mounting studs and then remove the engine cover from the vehicle.

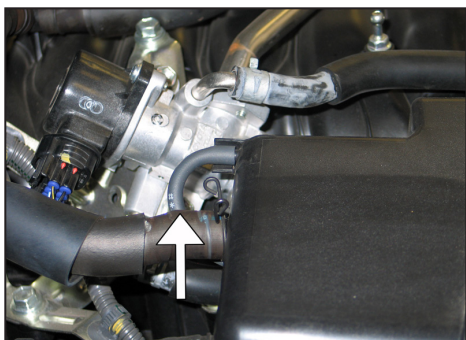

3. Disconnect the fuel pressure regulator vacuum hose from the intake tube.

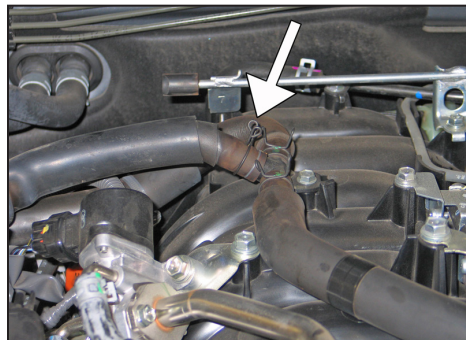

4. Disconnect the crankcase vent hose from the TEE fitting on top of the intake manifold plenum.



5. Disconnect the mass air sensor electrical connection and unhook the wiring harness from the upper airbox.



6. Loosen the hose clamp that secures the factory intake tube to the throttle body.

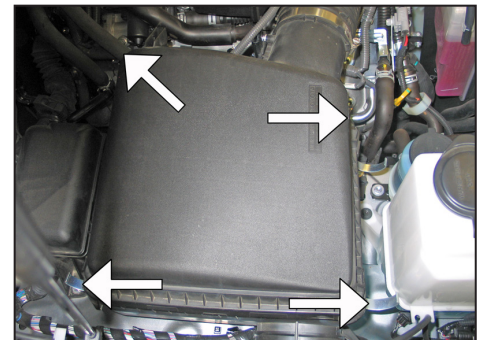

7. Release the four latches' securing the upper airbox to the lower airbox.



8. Remove the upper airbox/intake hose assembly from the vehicle.

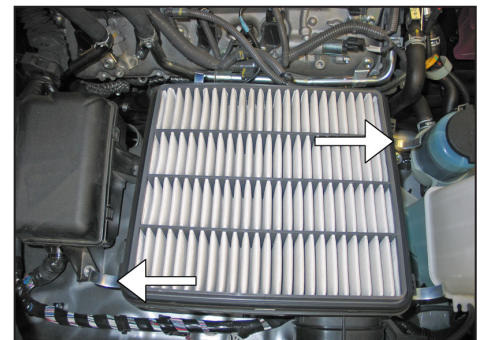

9. Loosen the two bolts securing the lower airbox into the vehicle.

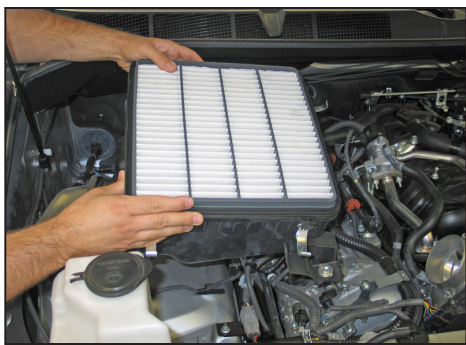

10. Remove the lower airbox from the vehicle.
NOTE: K&N Engineering, Inc., recommends that customers do not discard factory air intake.

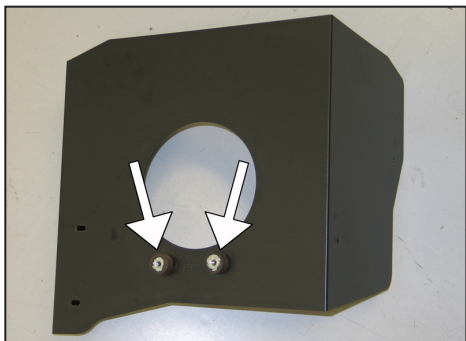

11. Install the two rubber mounted studs onto the heat shield using the provided hardware as shown.

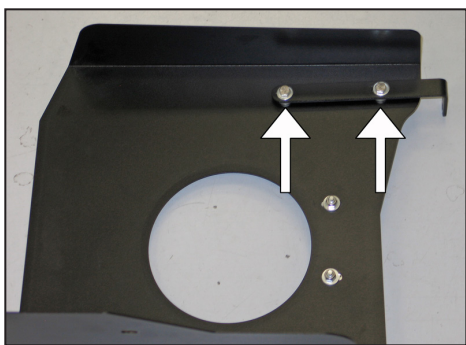

12. Install the heat shield mounting bracket (070902) onto the heat shield using the provided hardware and spacers as shown.

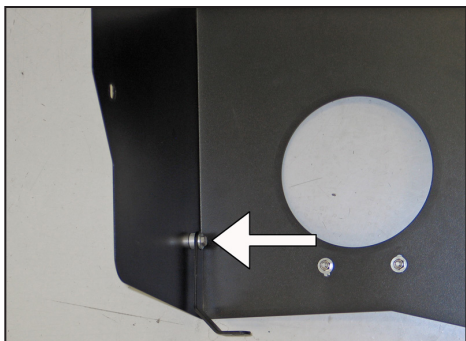

13. Install the provided heat shield mounting bracket (07190) onto the heat shield using the provided hardware and spacer as shown.

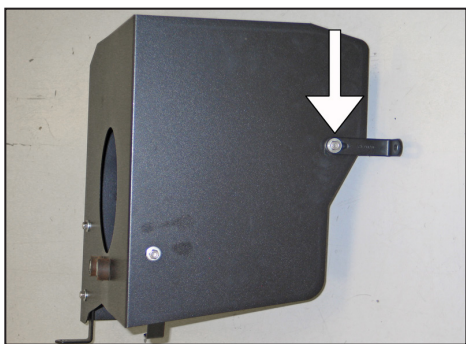

14. Install the provided heat shield mounting bracket (070742) onto the heat shield using the provided hardware and spacer as shown.

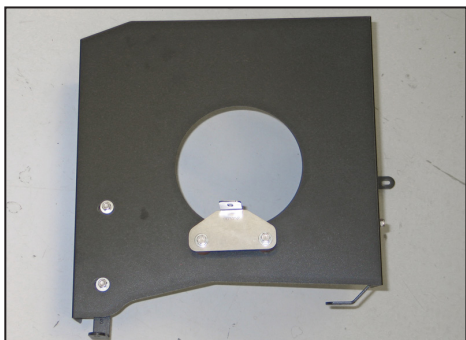

15. Install the tube mounting bracket (083152) onto the rubber mounted studs as shown using the provided hardware.

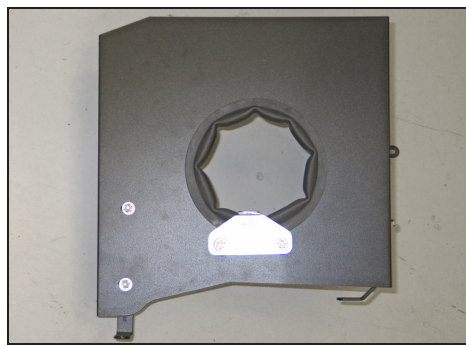

16. Install the provided shorter edge trim into the hole of the heat shield as shown.
NOTE: Trimming of the edge trim will be necessary.

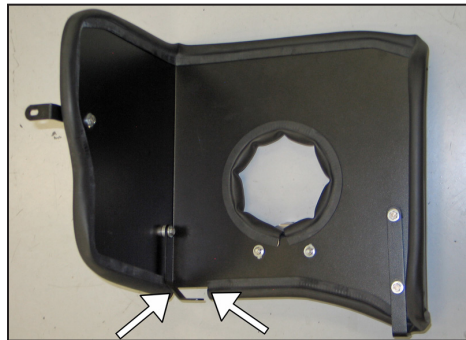

17. Install the provided longer edge trim onto the heat shield as shown.
NOTE: Trimming of the edge trim will be necessary.

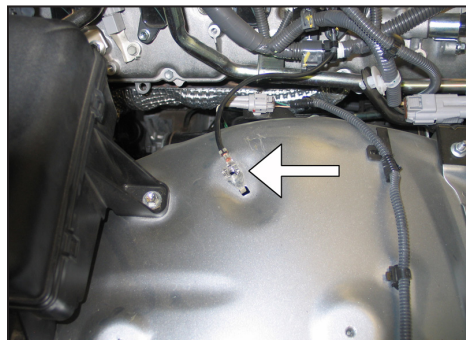

18. Remove the bolt that secures the ground strap to the inner fender.
NOTE: This bolt will be reused.

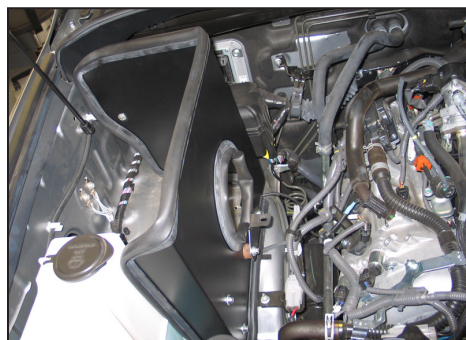

19. Set the heat shield into position on the inner fender and then secure with the factory bolt removed in step #18 and the provided hardware.
NOTE: Be sure to place the ground strap between the inner fender and bracket.



20. Remove the mass air sensor from the factory airbox.

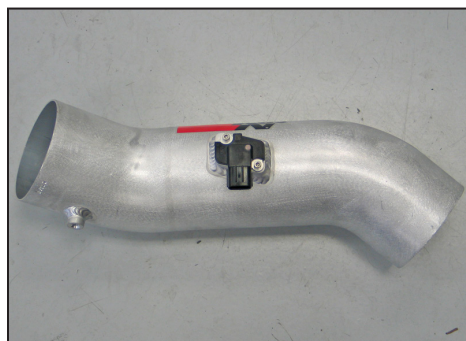

21. Install the mass air sensor into the K&N® intake tube and secure with the provided hardware.

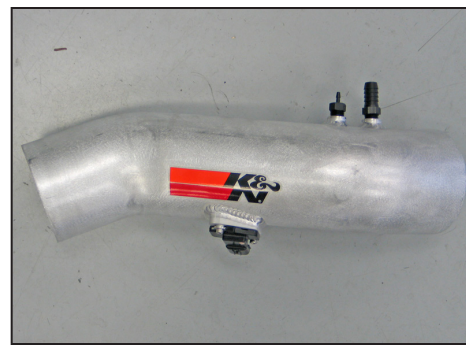

22. Install the provided NPT fittings into the K&N® intake tube as shown.
NOTE: Plastic NPT fittings are easy to cross thread. Install the vent fitting "hand" tight, then turn it two complete turns with a wrench.



23. Install the provided silicone hose (08050) onto the throttle body as shown, secure with the provided hose clamp.



24. Install the K&N® intake tube into the silicone hose at the throttle body and align with the mounting bracket attached to the heat shield. Secure the intake tube with the provided hardware and hose clamp.



25. Install the provided filter adapter into the K&N® air filter and secure with the hose clamp.
NOTE: Drycharger® air filter wrap; part # RF-1042DK is available to purchase separately. To learn more about Drycharger® filter wraps or look up color availability please visit <http://www.knfilters.com>.

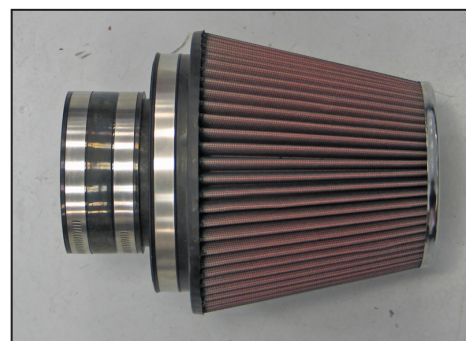

26. Install the silicone hose (08625) onto the filter adapter and secure with the provided hose clamp.

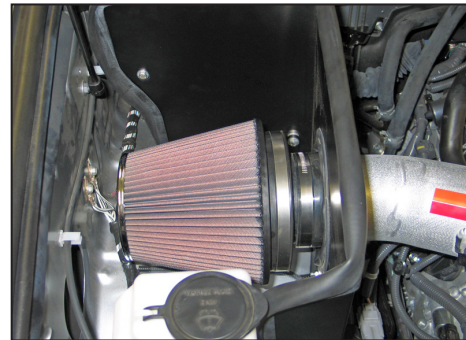

27. Install the filter assembly onto the K&N® intake tube and secure with the provided hose clamp.

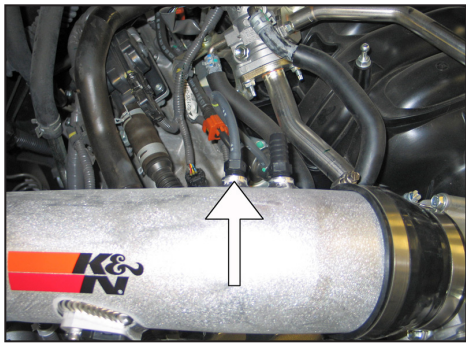

28. Reconnect the fuel pressure regulator vent line to the NPT fitting as shown.

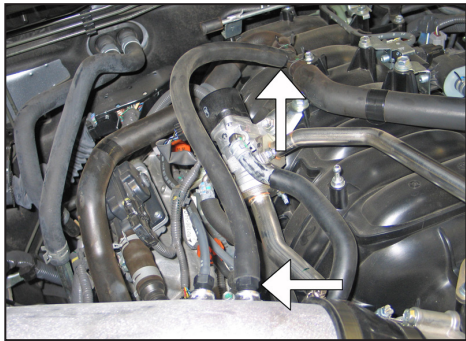

29. Connect the provided crankcase vent line to the NPT fitting and then to the factory TEE fitting on the intake plenum as shown.



30. Reconnect the mass air sensor electrical connection.



31. Reinstall the engine cover.



32. Reconnect the vehicle's negative battery cable. Double check to make sure everything is tight and properly positioned before starting the vehicle.

33. It will be necessary for all K&N® high flow intake systems to be checked periodically for realignment, clearance and tightening of all connections. Failure to follow the above instructions or proper maintenance may void warranty.

ROAD TESTING:

1. Start the engine with the transmission in neutral or park, and the parking brake engaged. Listen for air leaks or odd noises. For air leaks secure hoses and connections. For odd noises, find cause and repair before proceeding. This kit will function identically to the factory system except for being louder and much more responsive.

2. Test drive the vehicle. Listen for odd noises or rattles and fix as necessary.

3. If road test is fine, you can now enjoy the added power and performance from your kit.

4. K&N Engineering, Inc., requires cleaning the intake system's air filter element every 100,000 miles. When used in dusty or off-road environments, our filters will require cleaning more often. We recommend that you visually inspect your filter once every 25,000 miles to determine if the screen is still visible. When the screen is no longer visible some place on the filter element, it is time to clean it. To clean and re-oil, purchase our filter Recharger® service kit, part number 99-5050 or 99-5000 and follow the easy instructions.

**LEGAL IN CALIFORNIA ONLY FOR RACING VEHICLES
WHICH MAY NEVER BE USED, REGISTERED
OR LICENSED FOR USE UPON A HIGHWAY.**

See knfilters.com for CARB status on each part for a specific vehicle