



NOT LEGAL FOR SALE OR USE ON ANY POLLUTION CONTROLLED MOTOR VEHICLE IN CALIFORNIA OR STATES ADOPTING CALIFORNIA EMISSION PROCEDURES.

See knfilters.com for CARB status on each part for a specific vehicle

## INSTALLATION INSTRUCTIONS

### 77-3087KP CHEVROLET / GMC 2015 Silverado / Sierra V8-6.6L Turbo Diesel

NOTE: This kit was not designed to fit vehicles with a body lift.

#### TOOLS NEEDED:

ratchet  
extension  
10mm socket  
flat blade screw driver  
10mm wrench  
3mm allen wrench  
t20 torx.

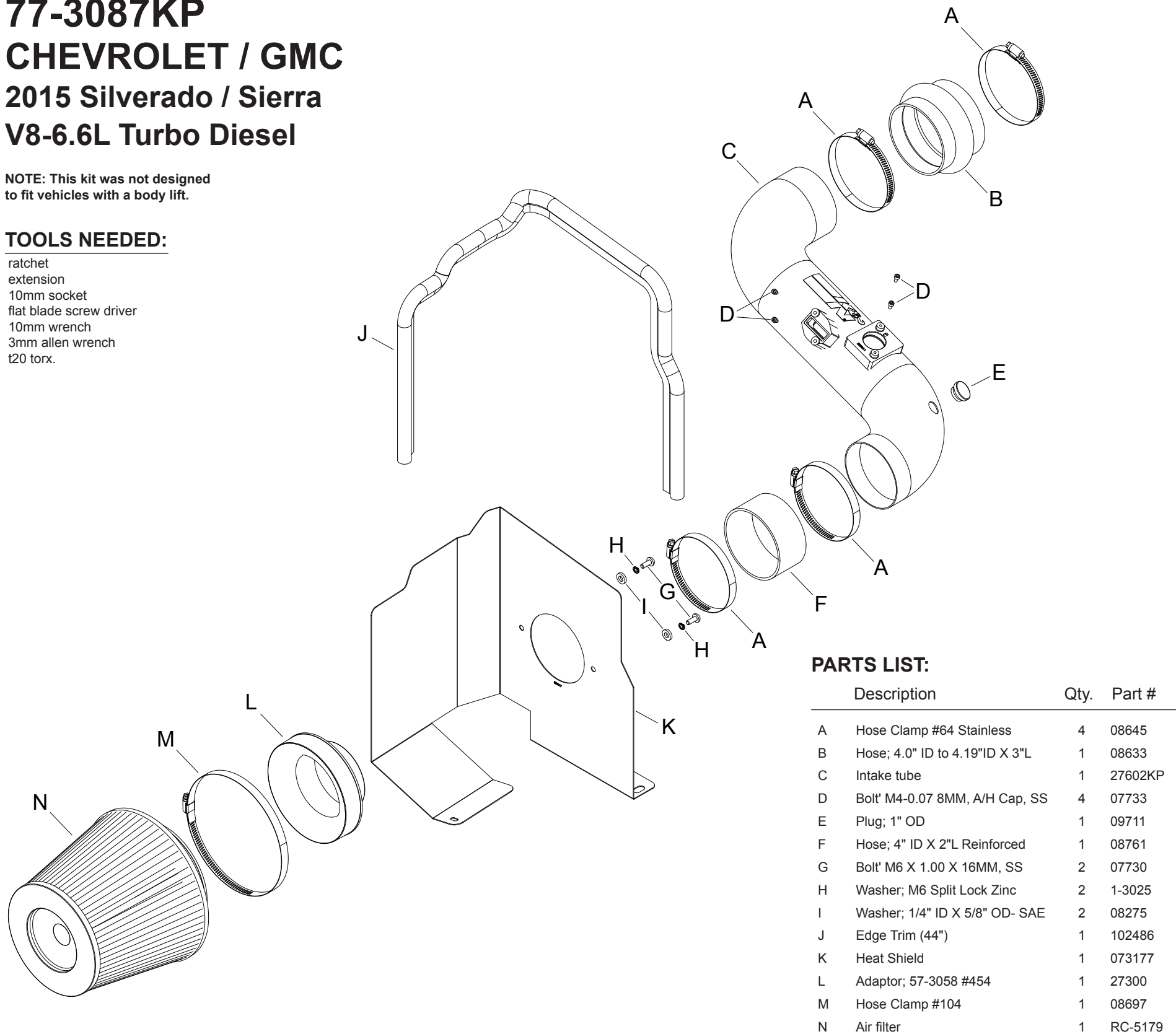

#### PARTS LIST:

Description	Qty.	Part #
A Hose Clamp #64 Stainless	4	08645
B Hose; 4.0" ID to 4.19"ID X 3"L	1	08633
C Intake tube	1	27602KP
D Bolt' M4-0.07 8MM, A/H Cap, SS	4	07733
E Plug; 1" OD	1	09711
F Hose; 4" ID X 2"L Reinforced	1	08761
G Bolt' M6 X 1.00 X 16MM, SS	2	07730
H Washer; M6 Split Lock Zinc	2	1-3025
I Washer; 1/4" ID X 5/8" OD- SAE	2	08275
J Edge Trim (44")	1	102486
K Heat Shield	1	073177
L Adaptor; 57-3058 #454	1	27300
M Hose Clamp #104	1	08697
N Air filter	1	RC-5179

**NOTE: FAILURE TO FOLLOW INSTALLATION INSTRUCTIONS AND NOT USING THE PROVIDED HARDWARE MAY DAMAGE THE INTAKE TUBE, THROTTLE BODY AND ENGINE.**

#### TO START:

1. Turn off the ignition and disconnect the negative battery cable.  
**NOTE: Disconnecting the negative battery cable erases pre-programmed electronic memories. Write down all memory settings before disconnecting the negative battery cable. Some radios will require an anti-theft code to be entered after the battery is reconnected. The anti-theft code is typically supplied with your owner's manual. In the event your vehicles anti-theft code cannot be recovered, contact an authorized dealership to obtain your vehicles anti-theft code.**



2. Disconnect the mass air sensor and humidity sensor electrical connections.

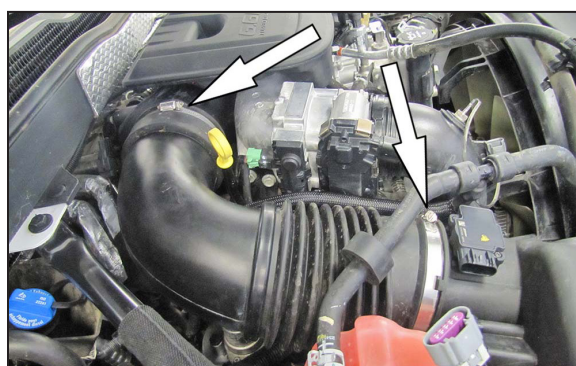

3. Loosen the hose clamps securing the factory intake hose to the air box and turbo inlet.



4. Lift up the hood seal trim and remove the bolt securing the fender brace.

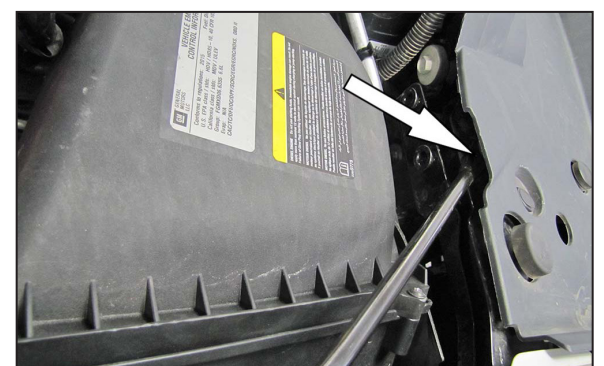

5. Loosen the bolt securing the fender brace to the core support then swing the brace clockwise towards the radiator for clearance.





6. Lift up and remove the air box from the vehicle.  
**NOTE: K&N Engineering, Inc., recommends that customers do not discard factory air intake.**

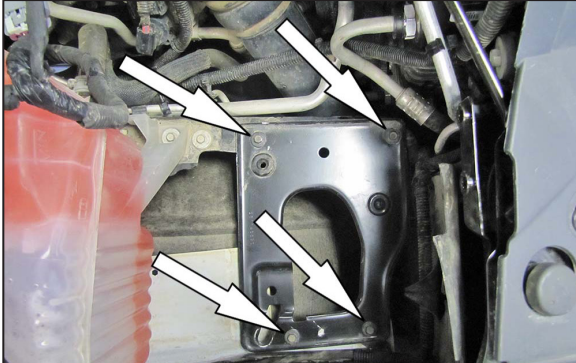

7. Remove the four bolts securing the air box mounting tray and then remove the tray from the vehicle.  
**NOTE: Three of these bolts will be reused in a latter step.**



8. Install the provided edge trim onto the heat shield as shown.  
**NOTE: Some trimming of the edge trim will be necessary.**



9. Install the provided filter adapter onto the heat shield and secure with the provided hardware.

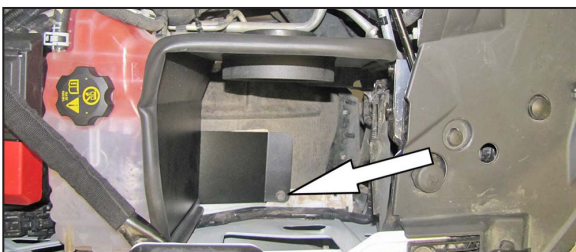

10. Install the heat shield assembly into the vehicle and secure with one of the factory bolts removed in step #7 to the fender.  
**NOTE: Do not install the two inner mounting bolts at this time.**



11. Flex the heat shield back and then install the K&N® air filter onto the filter adapter and secure with the provided hose clamp. Secure the heat shield with two of the factory bolts removed in step #7.



12. Install the coupling hose (08761) onto the filter adapter and secure with the provided hose clamp.



13. Install the provided coupling hose (08633) onto the turbo inlet and secure with the provided hose clamp.



14. Remove the screws securing the mass air sensor and Humidity sensors into the factory air box and then remove the sensors from the air box.



15. Install the Mass air sensor and Humidity sensor into the K&N® intake tube and secure with the provided hardware.

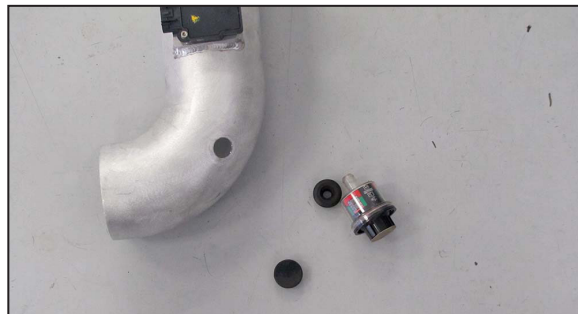

16. On vehicles equipped with a filter minder, remove the filter minder and grommet from the factory air box and install them into the K&N® intake tube. On vehicles not equipped with a filter minder, install the provided plug into the K&N® intake tube.  
**NOTE: The plug is an extremely tight fit to prevent any possible air leaks. It may be useful to use a flat blade screw driver to help push the lip of the plug through the hole. Care must be used to insure the plug is not damaged.**



17. Install the K&N® intake tube into the hump hose at the turbo inlet and then into the hose at the filter adapter, adjust the tube for best fit and then secure with the provided hose clamp.

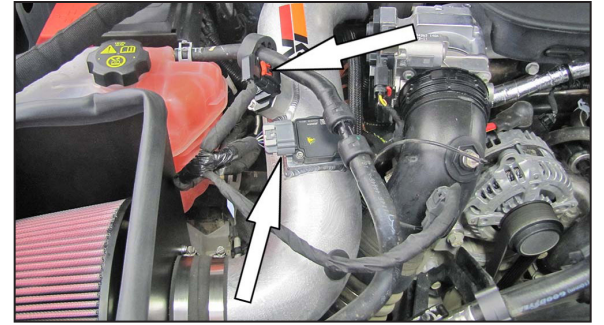

18. Reconnect the Mass air sensor and humidity sensor electrical connections.



19. Reinstall the fender brace and secure with the factory hardware.



20. Reconnect the vehicle's negative battery cable. Double check to make sure everything is tight and properly positioned before starting the vehicle.

21. It will be necessary for all K&N® high flow intake systems to be checked periodically for realignment, clearance and tightening of all connections. Failure to follow the above instructions or proper maintenance may void warranty.

#### ROAD TESTING:

1. Start the engine with the transmission in neutral or park, and the parking brake engaged. Listen for air leaks or odd noises. For air leaks secure hoses and connections. For odd noises, find cause and repair before proceeding. This kit will function identically to the factory system except for being louder and much more responsive.

2. Test drive the vehicle. Listen for odd noises or rattles and fix as necessary.

3. If road test is fine, you can now enjoy the added power and performance from your kit.

4. K&N Engineering, Inc., requires cleaning the intake system's air filter element every 100,000 miles. When used in dusty or off-road environments, our filters will require cleaning more often. We recommend that you visually inspect your filter once every 25,000 miles to determine if the screen is still visible. When the screen is no longer visible some place on the filter element, it is time to clean it. To clean and re-oil, purchase our filter Recharger® service kit, part number 99-5050 or 99-5000 and follow the easy instructions.

**NOT LEGAL FOR SALE OR USE ON ANY POLLUTION CONTROLLED MOTOR VEHICLE IN CALIFORNIA OR STATES ADOPTING CALIFORNIA EMISSION PROCEDURES.**

See [knfilters.com](http://knfilters.com) for CARB status on each part for a specific vehicle

\* FREE K&N® decal To register your warranty, please see us online at [knfilters.com/register](http://knfilters.com/register). FREE K&N® decal \*