



TYPHOON INTAKE SYSTEMS



INSTALLATION INSTRUCTIONS

69-8609
TOYOTA

2002-06 Camry

2002-06 Solara

L4-2.4L

NOTE: C.A.R.B. E.O. # D-269-37

APPLIES ONLY TO 2002-03 MODEL

YEAR VEHICLES

TOOLS NEEDED:

Flat Blade Screwdriver
Phillips Screwdriver
Ratchet
Extension
10mm Socket
Pliers
17mm Wrench
3mm Allen Wrench

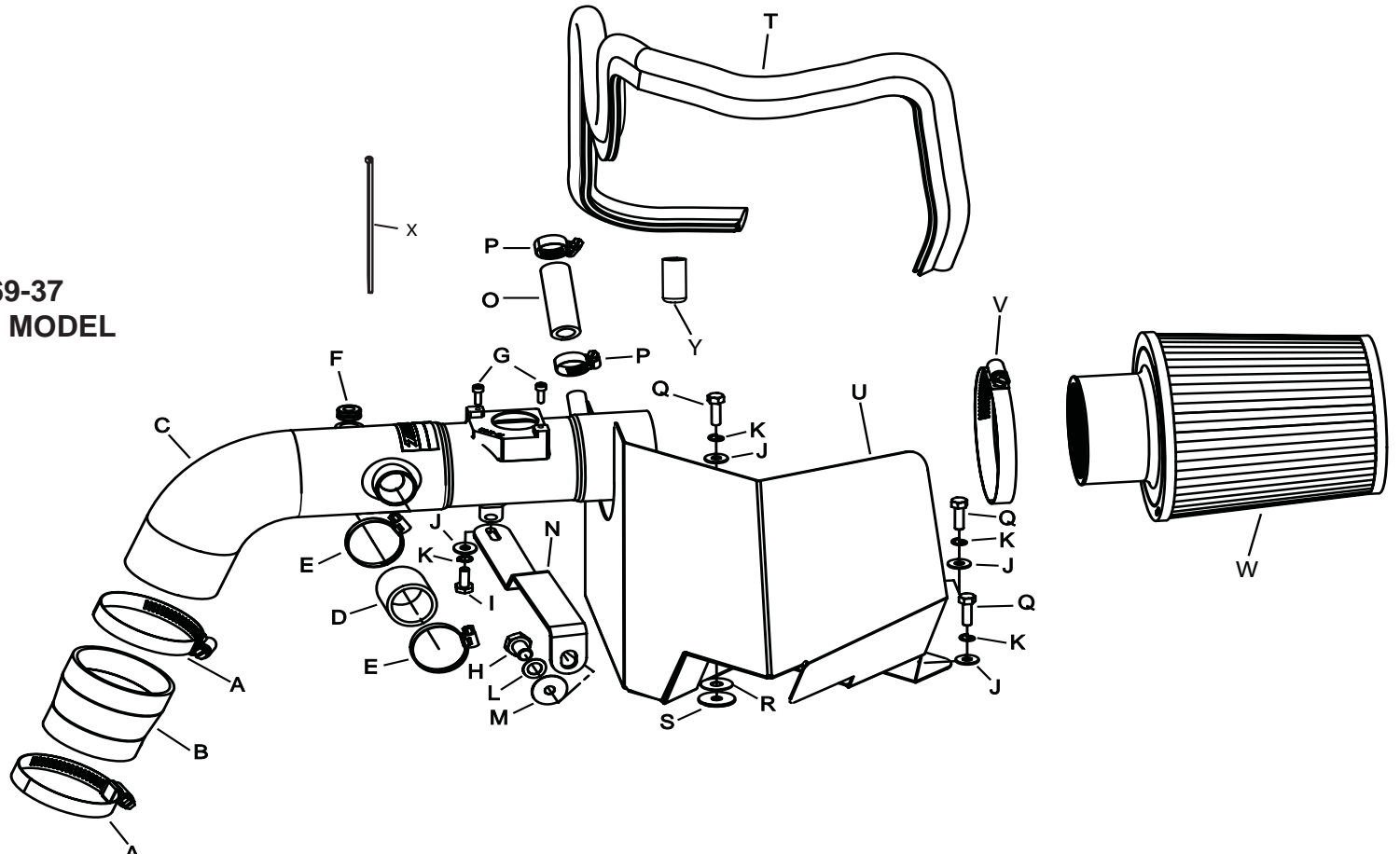

PARTS LISTED:

Description	Qty.	Part #	Description	Qty.	Part #	Description	Qty.	Part #
A Hose Clamp #40	2	08554	J Washer; 6MM Flat, SS	4	08269	S Washer; 1" X .300 X .100	1	21685
B HOSE; 2-1/2" TO 2-3/4" TPRD	1	084016	K Washer; 1/4" Lock, ZN	4	08198	T Edge Trim	1	102496
C Intake Tube	1	27523	L Washer; 10MM Wave	1	08175	U Heat Shield	1	07644
D Hose; 1-1/8"ID X 2"L,	1	084074	M Washer; 1"D X 1/4 Hole Fender	1	08160	V Hose Clamp #44	1	08577
E Hose Clamp #16 Mini	2	08427	N Bracket; "L", STL, FB/PC	1	26651	W Air Filter	1	RU-4960
F Grommet; .450"od, .300"id, .075"	1	082005	O Hose; 1/2"ID X 2.38"L,	1	08415	X Cable Tie	1	21590
G Bolt; M4-0.07 8MM, A/H Cap, SS	2	07733	P Hose Clamp #6 Mini	2	08407	Y Vinyl Caplug 1/2"ID, 1" Long	1	08120
H Bolt; M10-1.25x16mm Hex Head	1	071002	Q Bolt; M6x1.00"x20MM Hex, SS	3	07795			
I Bolt; 6MM-1.00x16MM, SS	1	07812	R Washer; 3/8" Flat Washer, SS	1	08134			

NOTE: FAILURE TO FOLLOW INSTALLATION INSTRUCTIONS AND NOT USING THE PROVIDED HARDWARE MAY DAMAGE THE INTAKE TUBE, THROTTLE BODY AND ENGINE.

TO START:

1. Turn off the ignition and disconnect the negative battery cable.

NOTE: Disconnecting the negative battery cable erases pre-programmed electronic memories. Write down all memory settings before disconnecting the negative battery cable. Some radios will require an anti-theft code to be entered after the battery is reconnected. The anti-theft code is typically supplied with your owner's manual. In the event your vehicles' anti-theft code cannot be recovered, contact an authorized dealership to obtain your vehicles anti-theft code.



2. Disconnect the mass sensor electrical connection by depressing the center tab and gently pulling the harness away from the mass air sensor.



3. Remove the pulse width modulated (PWM) vacuum switching valve from the stock intake tube by gently pulling upwards until the PWM vacuum switching valve is released.



4. Compress and slide back factory hose clamp and remove the crank case vent hose/chamber from the stock intake tube as shown in the photograph.



5. On vehicles not equipped with the "EVAP canister closed valve", install the supplied caplug onto the K&N intake tube. Loosen the two upper air box mounting bolts, then remove the screw that secures the "EVAP canister closed valve" to the upper airbox as shown in the photograph.

NOTE: Some vehicles may not be equipped with the "EVAP canister closed valve".



6. Release the clamp that secures the stock intake tube to the throttle body. Then, remove the factory intake tube/upper air box as shown in the photograph.



7. Remove the three lower air box mounting bolts; then, release the two wiring harness mounting clips which secure the wiring harness to the lower air box.



8. Remove the lower air box from its place of attachment as shown in the photograph.
NOTE: K&N Engineering, Inc., recommends that customers do not discard factory air intake.



9. Using the provided tie wrap, secure the heater hose to the throttle body bypass hoses as shown in the photograph.



10. Install the provided edge trim onto the heat shield as shown in the photograph.

NOTE: Some trimming of the edge trim may be necessary.



11. Place the provided rubber washer and fender washer onto the lower air box mount as shown in the photograph.



12. Set the heat shield into position on the lower air box mount and inner fender. Using the provided hardware, secure the heat shield to the three original lower air box mount's threaded holes.



13. Install the intake tube mounting bracket (26651) onto the engine using the provided hardware as shown in the photograph.

NOTE: The bracket (26651) will fasten to the threaded boss at the rear corner of the cylinder head.



14. Install the supplied silicone hose (084016) onto the throttle body and secure with the supplied hose clamp.



15. Remove the two screws that secure the mass air sensor into the stock air box; then, remove the mass air sensor.



16. Install the mass air sensor into the K&N® intake tube and secure with provided hardware.



17. Install the provided silicone hose (084074) onto the K&N® intake tube and secure with the provided hose clamp.

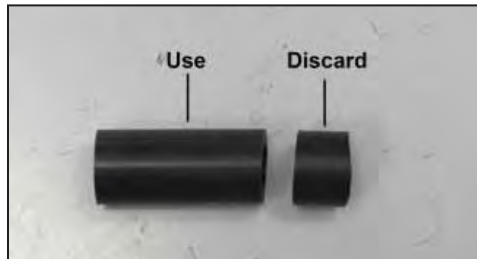

18. Cut the provided silicone hose (08415) hose from 2-3/8" (as supplied) to 1-3/4" long as shown in the photograph.



19. Install the newly cut 1-3/4" long silicone hose (08415) onto the K&N® intake tube and secure with the provided hose clamp as shown in the photograph.

NOTE: On vehicles not equipped with the "EVAP canister closed valve", install the supplied capplug onto the K&N® intake tube.



20. Install the provided grommet into the welded bracket on the K&N® intake tube.



21. Install the K&N® intake tube into the silicone (084016) hose on the throttle body; and align with the intake tube mounting bracket which was installed in step 13.



22. Install the crank case vent hose/chamber into the silicone hose installed onto the K&N® intake tube in step 19; secure with the provided hose clamp.



23. On vehicles not equipped with an "EVAP canister closed valve", install the "EVAP canister closed valve" into the silicone hose which was installed in step 19; secure with the provided hose clamp.



24. Install the pulse width modulated (PWM) switching valve into the grommet on the welded bracket on the intake tube as shown in the photograph.

NOTE: Care must be taken to prevent the grommet from being pushed out of the welded bracket.



25. Install the K&N® air filter onto the intake tube; secure with the provided hose clamp.



26. Reconnect the mass air sensor electrical connection.



27. Reconnect the vehicle's negative battery cable. Check to ensure all hose clamps and fittings are properly tightened and positioned correctly before starting the vehicle.

28. The C.A.R.B. exemption sticker, (attached), must be visible under the hood so that an emissions inspector can see it when the vehicle is required to be tested for emissions. California requires testing every two years, other states may vary.

29. It will be necessary for all K&N® high flow intake systems to be checked periodically for realignment, clearance and tightening of all connections. Failure to follow the above instructions or proper maintenance may void warranty.

ROAD TESTING:

1. Start the engine with the transmission in neutral or park, and the parking brake engaged. Listen for air leaks or odd noises. For air leaks secure hoses and connections. For odd noises, find cause and repair before proceeding. This kit will function identically to the factory system except for being louder and much more responsive.

2. Test drive the vehicle. Listen for odd noises or rattles and fix as necessary.

3. If road test is fine, you can now enjoy the added power and performance from your kit.

4. K&N Engineering, Inc., suggests checking the air filter element periodically for excessive dirt build-up. When the element becomes covered in dirt (or once a year), service it according to the instructions on the Recharger® service kit, part number 99-5000 or 99-5050.

STREET LEGAL IN MOST STATES

**NOT LEGAL FOR USE IN CA & OTHER STATES
ADOPTING CA EMISSIONS STANDARDS**

See our catalog or knfilters.com for CARB status on each part for a specific vehicle

Free K&N® Decal To register your warranty, please see us online at knfilters.com/register. Free K&N® Decal