



TYPHOON INTAKE SYSTEMS



INSTALLATION INSTRUCTIONS

69-4520
CHEVROLET
2010-11 Camaro
V6-3.6L

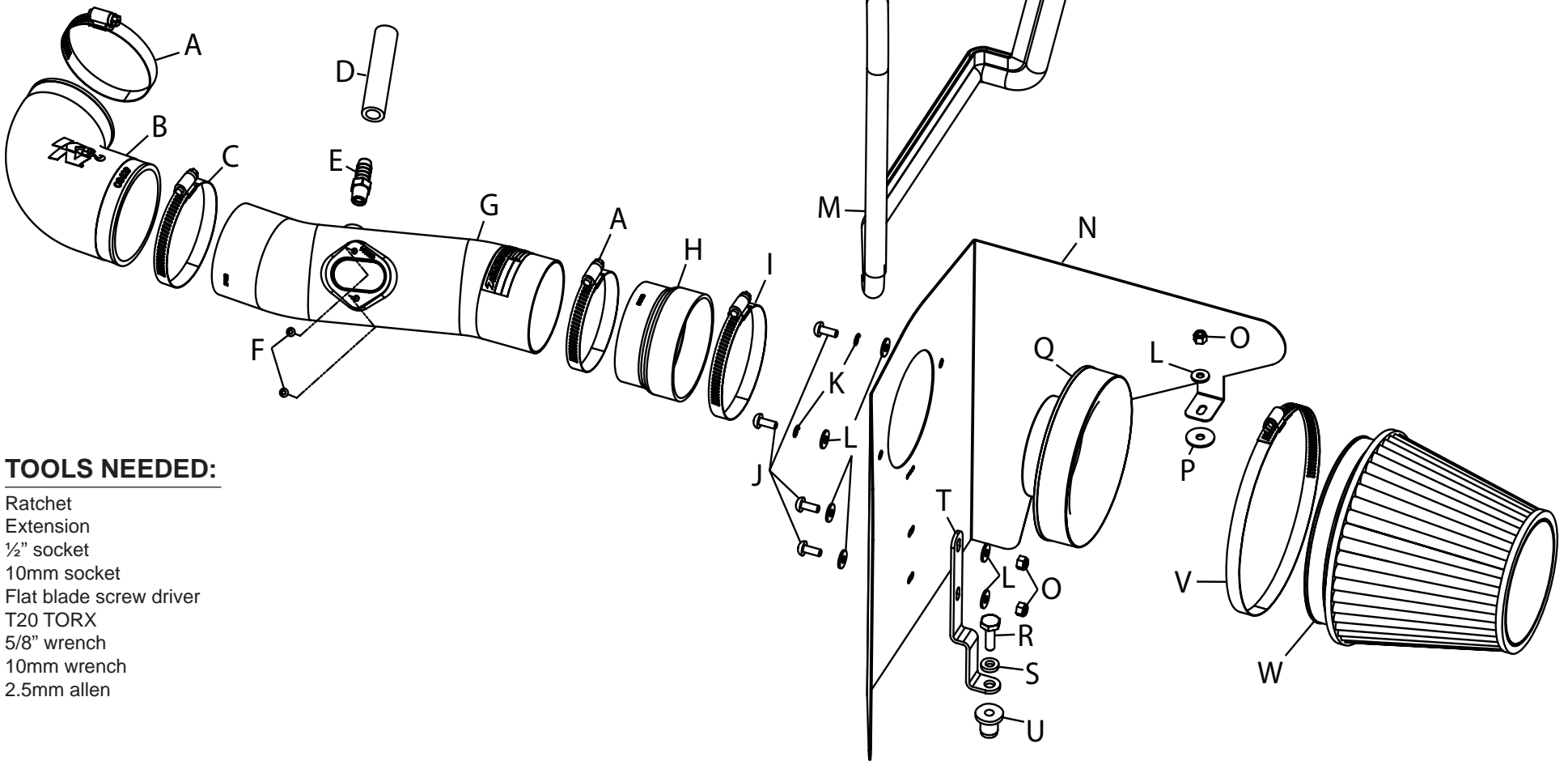

TOOLS NEEDED:

- Ratchet
- Extension
- 1/2" socket
- 10mm socket
- Flat blade screw driver
- T20 TORX
- 5/8" wrench
- 10mm wrench
- 2.5mm allen

PARTS LIST:

Description	Qty.	Part #	Description	Qty.	Part #	Description	Qty.	Part #
A Hose Clamp #48	2	08601	I Hose Clamp #56	1	08620	Q Adapter; Universal, 6" Filter 3.5"	1	21512-1
B Hose; 3-1/4" TO 3"ID 90deg Angled	1	08629	J Bolt; M6 X 1.00 X 16MM , Bttnhd	4	07730	R Bolt; 5/16"- 18 X 1"L,SS	1	07777
C Hose Clamp #52	1	08610	K Washer; 1/4" Lock, ZN	2	08198	S Washer; 5/16"ID X 5/8"OD, Flat	1	08276
D Hose; 1/2" ID X 3-1/2" L	1	087028	L Washer; 1/4"ID X 5/8"OD - SAE	7	08275	T Bracket; "Z", STL, TK/PC	1	083126
E Vent; Strt 1/2" Hose, 1/4"NPT	1	080022	M Edge Trim (70")	1	102454	U Insert; 5/16-18X.600 ODX.730L	1	088002
F Screw; M4- .7 X 12, BttnhdSS	2	07726	N Heat Shield	1	074053	V Hose Camp # 104	1	08697
G Intake Tube	1	27463	O Nut; 6MM Nylock, Hexhead	3	07553	W Air Filter	1	RF-1042
H 3.25"ID TO 3.50"ID X 2.25"L, Tprd	1	084091	P Washer; 1" X .300 X .100 Rubber	1	21685			

NOTE: FAILURE TO FOLLOW INSTALLATION INSTRUCTIONS AND NOT USING THE PROVIDED HARDWARE MAY DAMAGE THE INTAKE TUBE, THROTTLE BODY AND ENGINE.

TO START:

1. Turn off the ignition and disconnect the negative battery cable.

NOTE: Disconnecting the negative battery cable erases pre-programmed electronic memories. Write down all memory settings before disconnecting the negative battery cable. Some radios will require an anti-theft code to be entered after the battery is reconnected. The anti-theft code is typically supplied with your owner's manual. In the event your vehicles' anti-theft code cannot be recovered, contact an authorized dealership to obtain your vehicles anti-theft code.



2. Release the locking and then disconnect the mass air sensor electrical connector.

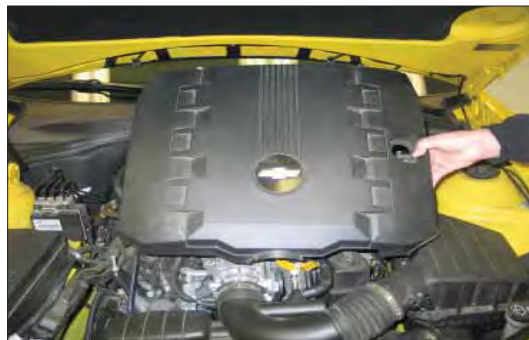

3. Remove the oil fill cap and then remove the engine cover from the engine. Reinstall the oil fill cap.



4. Disconnect the crank case vent hard line from the 90° connector hose on the factory intake tube.

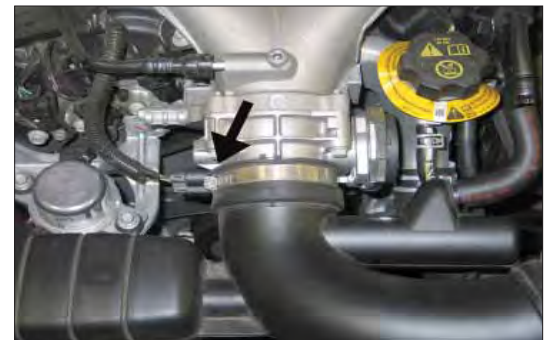

5. Loosen the hose clamp securing the intake tube to the throttle body.



6. Remove the two nuts shown securing the factory air box to the inner fender.



7. Remove the factory air box assembly from the vehicle.



8. Remove the air box mounting grommet shown from the inner fender.

NOTE: K&N Engineering, Inc., recommends that customers do not discard factory air intake.



9. Install the provided heat shield mounting bracket (083126) onto the heat shield using the provided hardware.

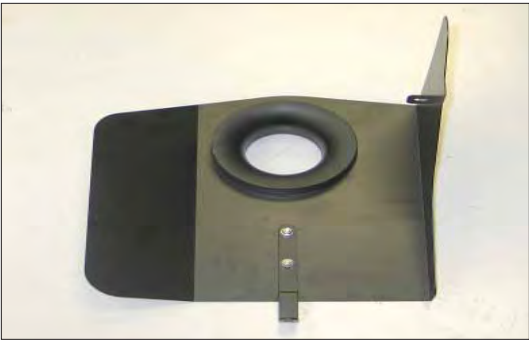

10. Install the filter adapter onto the heat shield and secure with the provided hardware.



11. Install the provided edge trim onto the heat shield as shown.

NOTE: Some trimming of the edge trim will be necessary.



12. Install the provided inserted nut onto the heat shield mounting bracket and secure with the provided hardware.

NOTE: Do not completely tighten at this time.



13. Install the provided rubber fender washer onto the outward air box mounting stud.



14. Install the heat shield assembly into the vehicle so the inserted nut goes into the air box mounting grommet hole and tab goes onto the air box mounting stud. Secure the heat shield with the provided hardware.



15. Install the provided silicone hose (084091) onto the filter adapter and secure with the provided hose clamp.



16. Install the provided 1/4npt vent fitting into the K&N intake tube as shown.



17. Remove the two screws securing the mass air sensor into the factory air box and then remove the mass air sensor from the air box.



18. Install the mass air sensor into the K&N intake tube and secure with the provided hardware.
NOTE: The o-ring seal provides a very tight seal, be sure the o-ring is properly seated as the sensor is being installed.



19. Install the provided elbow hose (08629) onto the K&N intake tube as shown and secure with the provided hose clamp.

NOTE: Do not completely tighten at this time.



20. Install the K&N intake tube assembly into the silicone hose at the filter adapter and then onto the throttle body, align for proper fit and then secure with the provided hose clamps.



21. Install the provided silicone hose onto the factory crank case vent tube and then connect the open end onto the vent fitting installed into the K&N intake tube.

NOTE: Some trimming of the vent hose will be necessary.



22. Install the K&N air filter and secure with the provided hose clamp.



23. Reconnect the mass air sensor electrical connection.



24. Reinstall the engine cover and secure with the oil fill cap.

NOTE: Some minor trimming to the corner of the engine cover may be necessary so the cover does not contact the intake tube.



25. Reconnect the vehicle's negative battery cable. Double check to make sure everything is tight and properly positioned before starting the vehicle.

26. It will be necessary for all K&N® high flow intake systems to be checked periodically for realignment, clearance and tightening of all connections. Failure to follow the above instructions or proper maintenance may void warranty.

ROAD TESTING:

1. Start the engine with the transmission in neutral or park, and the parking brake engaged. Listen for air leaks or odd noises. For air leaks secure hoses and connections. For odd noises, find cause and repair before proceeding. This kit will function identically to the factory system except for being louder and much more responsive.

2. Test drive the vehicle. Listen for odd noises or rattles and fix as necessary.

3. If road test is fine, you can now enjoy the added power and performance from your kit.

4. K&N Engineering, Inc., suggests checking the air filter element periodically for excessive dirt build-up. When the element becomes covered in dirt (or once a year), service it according to the instructions on the Recharger® service kit, part number 99-5050 or 99-5000

STREET LEGAL IN MOST STATES

**NOT LEGAL FOR USE IN CA & OTHER STATES
ADOPTING CA EMISSIONS STANDARDS**

See our catalog or knfilters.com for CARB status on each part for a specific vehicle

* FREE K&N® decal To register your warranty, please see us online at knfilters.com/register. FREE K&N® decal *