



TYPHOON INTAKE SYSTEMS™

INSTALLATION INSTRUCTIONS

69-3515
FORD
2006-09 Fusion
V6-3.0L

TOOLS NEEDED:

- 3mm Allen Wrench
- 8mm Socket
- 10mm Socket
- 13mm Socket
- Extension
- Flat Blade Screwdriver
- Phillips Screwdriver
- Pliers
- Ratchet

Product Available to Purchase Separately:

- Drycharger® air filter wrap; part numbers:
 • RX-4990DK, black Drycharger®
 • RX-4990DR, red Drycharger®
 • RX-4990DY, yellow Drycharger®

PARTS LIST:

Description	Qty.	Part #	Description	Qty.	Part #	Description	Qty.	Part #
A Hose Clamp #40	1	08554	J Washer; 1/4"ID X 5/8"OD - SAE	3	08275	S Heat Shield	1	074046
B Hose; 3"ID to 2-1/2"ID Tprd., Silc.	1	08713	K Washer; 1/4" Lock, ZN	1	08198	T Edge Trim (44")	1	102486
C Hose Clamp #48	1	08601	L Bolt; 8MM-1.25 X 16MM, Hexhead	1	07844	U Bolt; 8MM-1.25 X 35MM Hexhead, ZN	1	07784
D Intake Tube	1	27553	M Bolt; M4 - 0.07 8MM, A/H CAP, SS	2	07733	V Washer; 5/16-1.125" Fender	1	08130
E Vent; Strt. 1/2" Hose, 1/4"NPT, Plas.	1	080022	N Bracket; "L", Fin.	1	070602	W Spacer; .625"OD X .375"ID X .625"L, ZN	1	07849
F Hose; 1/2"ID X 12"L Black Silicone	1	087031	O Washer; 8MM, Flat, SS	2	08272	X Edge Trim (17")	1	102469
G Vent; Strt., 3/8"Hose, 1/4" NPT, Plas.	1	08047	P Washer; 8MM Spring (Wave)	2	08239	Y Hose Clamp #52	1	08610
H Hose; 10" 8MM	1	08156	Q Bolt; 6MM-1.00 X 16MM, SS	2	07812	Z Air Filter	1	RU-5176
I Bracket; "Z", STL, TK/PC	1	070121	R Nut; 6MM Nylock, Hexhead, SS	1	07512			

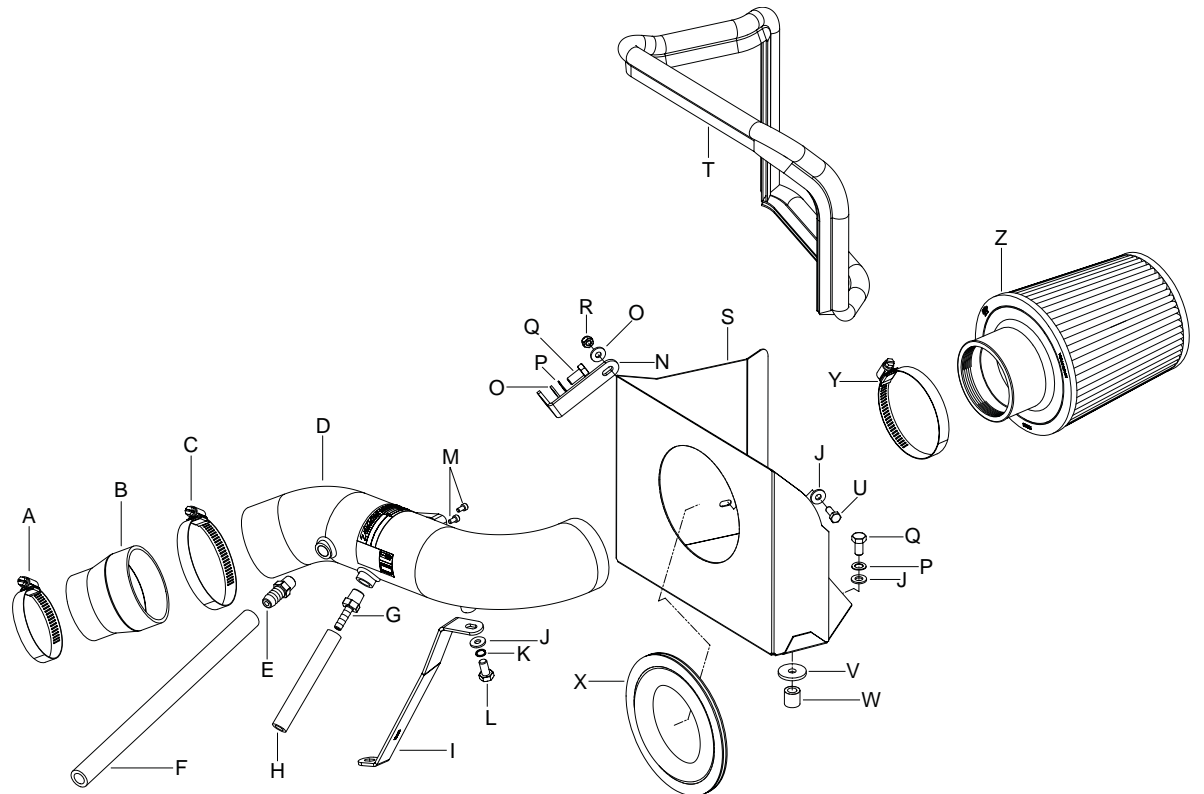

NOTE: FAILURE TO FOLLOW INSTALLATION INSTRUCTIONS AND NOT USING THE PROVIDED HARDWARE MAY DAMAGE THE INTAKE TUBE, THROTTLE BODY AND ENGINE.

TO START:

1. Turn off the ignition and disconnect the negative battery cable.

NOTE: Disconnecting the negative battery cable erases pre-programmed electronic memories. Write down all memory settings before disconnecting the negative battery cable. Some radios will require an anti-theft code to be entered after the battery is reconnected. The anti-theft code is typically supplied with your owner's manual. In the event your vehicles' anti-theft code cannot be recovered, contact an authorized dealership to obtain your vehicles anti-theft code.



2. Disconnect mass air sensor electrical connection.



3. Disconnect the crankcase vent hose from the valve cover port as shown.



4. Disconnect the EVAP vent hose from the tube as shown.



5. Loosen the hose clamp which secures the stock intake tube to the throttle body.



6. Remove the rubber air flap from behind the head light assembly as shown.



7. Lift up the airbox to dislodge it from the mounting grommet and then remove the complete intake assembly.
NOTE: K&N Engineering, Inc., recommends that customers do not discard factory air intake.



8. Remove the two bolts which secure the airbox mount. Then remove the airbox mount from the vehicle.



9. Remove the two screws which retain the mass air sensor and then remove the mass air sensor from the airbox.

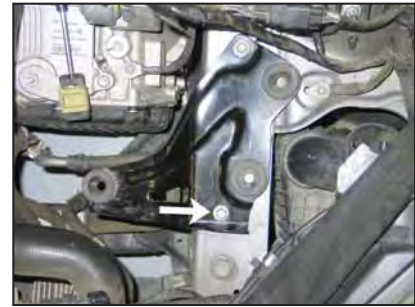

10. Install the mass air sensor into the K&N® intake tube and secure with the provided hardware.



11. Remove the ground strap mounting bolt shown from the transmission.
NOTE: This bolt will be reused in the next step.



12. Secure the tube mounting bracket to the transmission using the ground strap mounting bolt from step #11.

NOTE: Be sure to place the ground strap between the transmission and bracket.

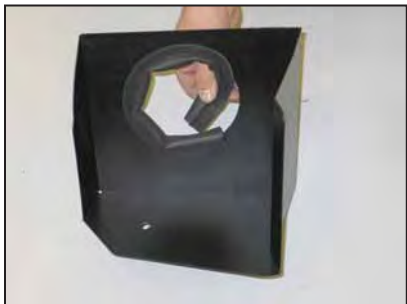

13. Install the short edge trim into the hole of the heat shield as shown.

NOTE: Some trimming of the edge trim will be necessary.

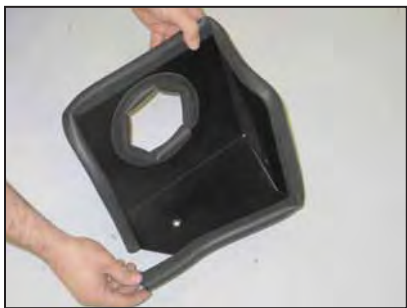

14. Install the long edge trim onto the heat shield as shown.

NOTE: Some trimming of the edge trim will be necessary.



15. Install the heat shield mounting bracket (070602) onto the inner frame rail using the provided hardware as shown.

NOTE: The mounting bolt will thread into the rear airbox mounting bolt location.



16. Place the heat shield spacer and fender washer onto the frame rail at the front airbox mounting location as shown.



17. Set the heat shield into position on the frame rail and secure with the provide hardware. Secure the rear of the heat shield to the mounting bracket with provided hardware.



18. Install the silicone hose (08713) onto the throttle body and secure with the provided hose clamp.



19. Install the two provided 1/4" NPT fittings into the K&N® intake tube as shown.



20. Install the K&N® intake tube into the silicone hose at the throttle body and align with the mounting bracket installed in step #12. Secure the intake tube with the hose clamp and hardware provided.



21. Install the provided crankcase vent hose onto the valve cover port and then onto the 1/4" NPT fitting installed into intake tube as shown.



22. Install the provided EVAP hose onto the port and then onto the 1/4" NPT fitting installed into the K&N® intake tube as shown.



23. Install the K&N® air filter and secure with the provided hose clamp.



24. Reconnect the mass air sensor electrical connection.



25. Reconnect the vehicle's negative battery cable. Double check to make sure everything is tight and properly positioned before starting the vehicle.

26. The C.A.R.B. exemption sticker, (attached), must be visible under the hood so that an emissions inspector can see it when the vehicle is required to be tested for emissions. California requires testing every two years, other states may vary.

27. It will be necessary for all K&N® high flow intake systems to be checked periodically for realignment, clearance and tightening of all connections. Failure to follow the above instructions or proper maintenance may void warranty.

ROAD TESTING:

1. Start the engine with the transmission in neutral or park, and the parking brake engaged. Listen for air leaks or odd noises. For air leaks secure hoses and connections. For odd noises, find cause and repair before proceeding. This kit will function identically to the factory system except for being louder and much more responsive.

2. Test drive the vehicle. Listen for odd noises or rattles and fix as necessary.

3. If road test is fine, you can now enjoy the added power and performance from your kit.

4. K&N Engineering, Inc., suggests checking the air filter element periodically for excessive dirt build-up. When the element becomes covered in dirt (or once a year), service it according to the instructions on the Recharger® service kit, part number 99-5050 or 99-5000.

50-STATE STREET LEGAL
K&N CARB EXEMPT K&N

* FREE K&N® decal To register your warranty, please see us online at knfilters.com/register. FREE K&N® decal *