



TYPHOON INTAKE SYSTEMS™

INSTALLATION INSTRUCTIONS

69-3510

Ford

2000-03 Focus

L4-2.0L DOHC exc. SVT

TOOLS NEEDED:

- Flat blade screw driver
- Ratchet
- 8mm socket
- Torx T20 wrench(provided)

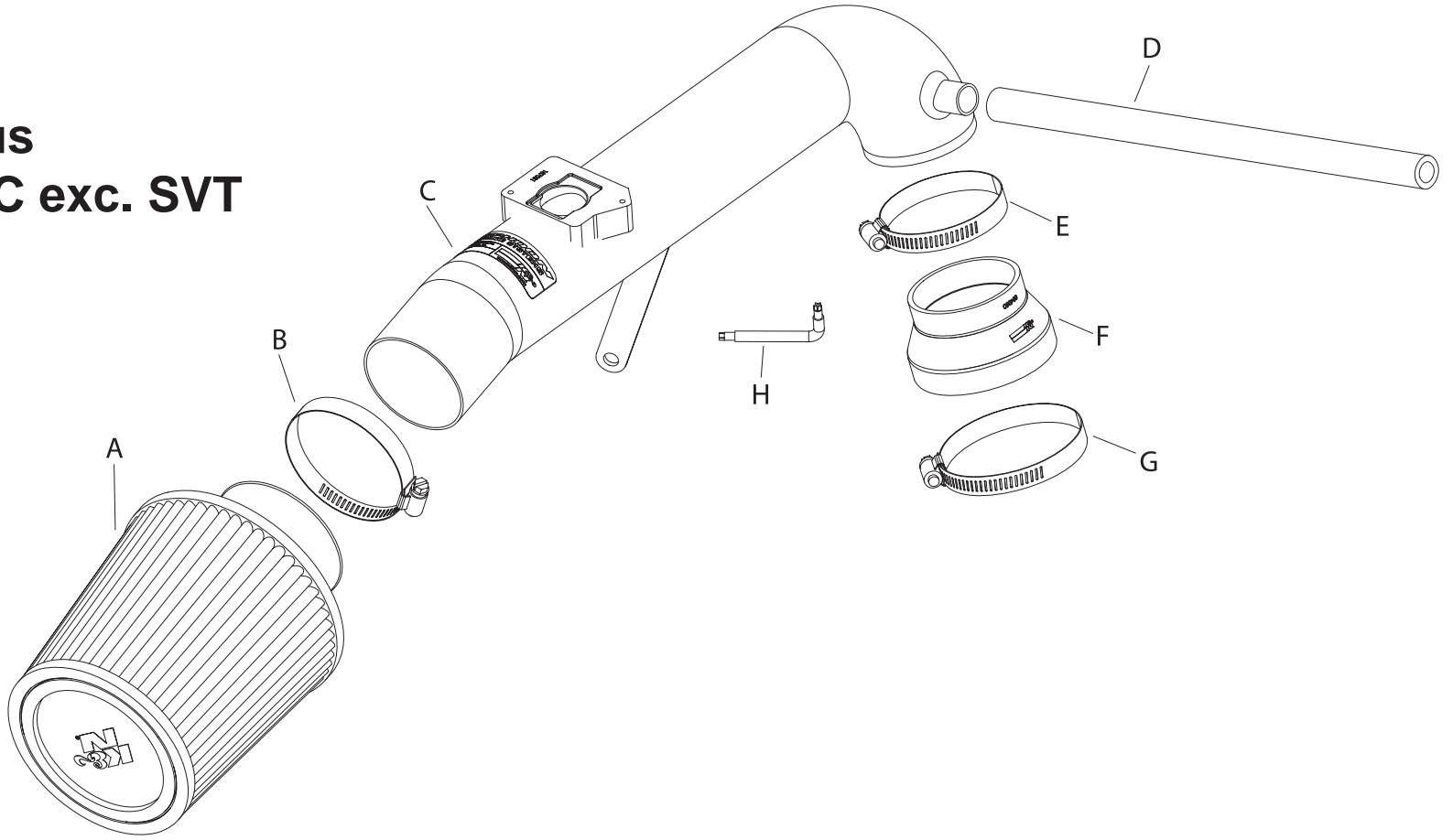

PARTS LIST:

Description	Qty.	Part #	Description	Qty.	Part #	Description	Qty.	Part #
A Air Filter	1	RU-4860	D Hose; 1/2"ID x 14"L, Silicone	1	08402	G Hose Clamp #48	1	08601
B Hose Clamp #40	1	08554	E Hose Clamp #44 SS	1	05860	H Wrench, T20 Torx	1	69801
C Typhoon Intake Tube	1	087081	F Hose; 2-1/2"ID to 3-1/4", Black	1	084050			

NOTE: FAILURE TO FOLLOW INSTALLATION INSTRUCTIONS AND NOT USING THE PROVIDED HARDWARE MAY DAMAGE THE INTAKE TUBE, THROTTLE BODY AND ENGINE.

TO START:

- Turn off the ignition and disconnect the negative battery cable.
NOTE: Disconnecting the negative battery cable erases pre-programmed electronic memories. Write down all memory settings before disconnecting the negative battery cable. Some radios will require an anti-theft code to be entered after the battery is reconnected. The anti-theft code is typically supplied with your owner's manual. In the event your vehicles' anti-theft code cannot be recovered, contact an authorized dealership to obtain your vehicles anti-theft code.



- Disconnect the mass air sensor electrical connection as shown.



- Loosen the hose clamps at the throttle body and at the mass air sensor, then, remove the stock intake tube as shown.



- Remove the four bolts that secure the air cleaner cover, then remove the cover and filter as shown.



- Remove the vent hose from the side of the lower air cleaner and valve cover.



- Pull firmly upwards to remove the lower air cleaner assembly as shown.
NOTE: K&N Engineering, Inc., recommends that customers do not discard factory air intake.



- Install the provided silicone hose and hose clamps onto the throttle body as shown.



- Remove the two bolts that secure the mass air sensor, then, remove the mass air sensor as shown.



- Install the mass air sensor into the K&N Typhoon intake tube using the stock bolts from step 8.
NOTE: Before installing the mass air sensor, inspect the inside of the tube for any debris, then clean the inside out with water and a towel. Inspect the tube one more time before proceeding to the next step.



10. Remove the rear bolt on the ignition bracket as shown.



11. Install the K&N Typhoon intake tube into the silicone hose then line up the bracket with the ignition bracket and secure with the bolt from step 10. Tighten the hose clamps using the 9/64 allen wrench provided.



12. Using the provided vent hose, (Trim to fit), connect to the K&N Typhoon intake tube and valve cover as shown.



13. Install the K&N air filter onto the K&N Typhoon intake tube and tighten with the provided hose clamp as shown.



14. Reconnect the mass air sensor electrical connection as shown.



15. Reconnect the vehicle's negative battery cable. Double check to make sure everything is tight and properly positioned before starting the vehicle.

16. The C.A.R.B. exemption sticker, (attached), must be visible under the hood, so the emissions inspector can see it when the vehicle is required to be tested for emissions. California requires testing every two years, other states may vary.

17. It will be necessary for all K&N® high flow intake systems to be checked periodically for realignment, clearance and tightening of all connections. Failure to follow the above instructions or proper maintenance may void warranty.

ROAD TESTING:

1. Start the engine with the transmission in neutral or park, and the parking brake engaged. Listen for air leaks or odd noises. For air leaks secure hoses and connections. For odd noises, find cause and repair before proceeding. This kit will function identically to the factory system except for being louder and much more responsive.

2. Test drive the vehicle. Listen for odd noises or rattles and fix as necessary.

3. If road test is fine, you can now enjoy the added power and performance from your kit.

4. K&N Engineering, Inc., suggests checking the air filter element periodically for excessive dirt build-up. When the element becomes covered in dirt (or once a year), service it according to the instructions on the Recharger® service kit, part number 99-5050 or 99-5000

50-STATE STREET LEGAL
K&N CARB EXEMPT
K&N

* FREE K&N® decal To register your warranty, please see us online at knfilters.com/register. FREE K&N® decal *

• 1455 CITRUS ST., P.O. BOX 1329, RIVERSIDE, CA., U.S.A. 92502 • TECH SERVICE 800-858-3333 • FAX 951-826-4001
 • e-mail: tech@knfilters.com • WWW: <http://www.knfilters.com>