



# TYPHOON INTAKE SYSTEMS

## INSTALLATION INSTRUCTIONS

69-1209

Honda

2004-07 Accord

I4-2.4L SULEV Only

**Tools:**

- Flat Blade Screw Driver
- Phillips screw driver
- Ratchet
- Extension
- 13mm Socket
- 10mm Socket
- 5.5mm Socket
- 2.5 mm Allen Wrench
- 4mm Allen Wrench
- 10mm Wrench

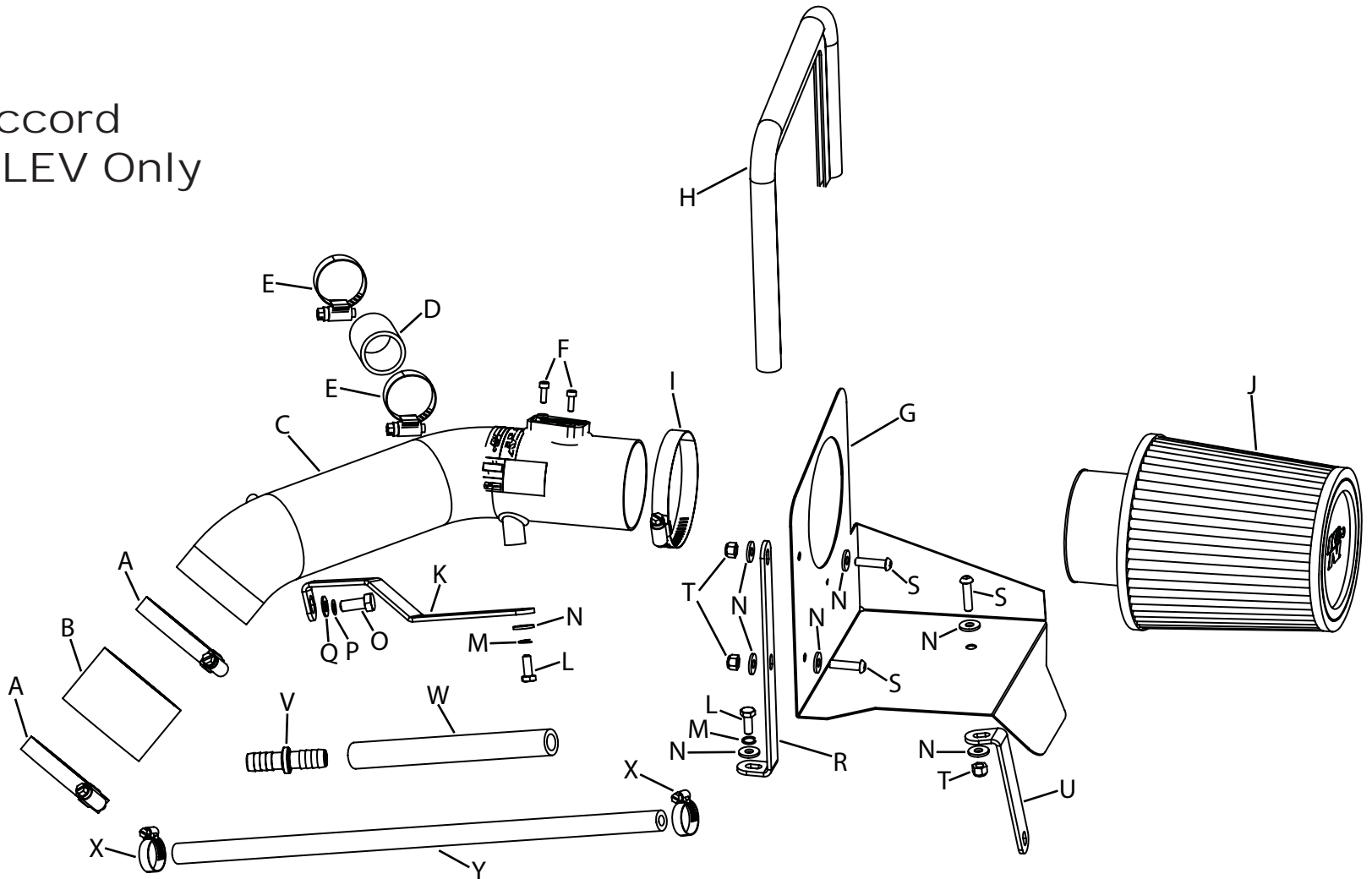

Description	Qty.	Part #	Description	Qty.	Part #	Description	Qty.	Part #
A	2	08554	I	1	08577	Q	1	08276
B	1	08440	J	1	RU-4870	R	1	06499
C	1	27534	K	1	06498	S	3	07730
D	1	084074	L	2	07812	T	3	07512
E	2	08413	M	2	08198	U	1	06497
F	2	07733	N	8	08275	V	1	08686
G	1	07353	O	1	07844	W	1	08159
H	1	102494	P	1	08239	X	2	21850
						Y	1	084007

**NOTE: FAILURE TO FOLLOW INSTALLATION INSTRUCTIONS AND NOT USING THE PROVIDED HARDWARE MAY DAMAGE THE INTAKE TUBE, THROTTLE BODY AND ENGINE.**

**TO START:**

1. Turn the ignition off and disconnect the vehicle's negative battery cable.

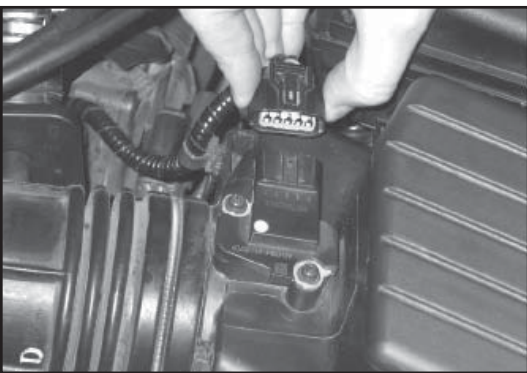

2. Depress the locking tab and remove the mass air sensor connector. Remove the clips securing the mass air sensor harness to the stock air box and intake tube.

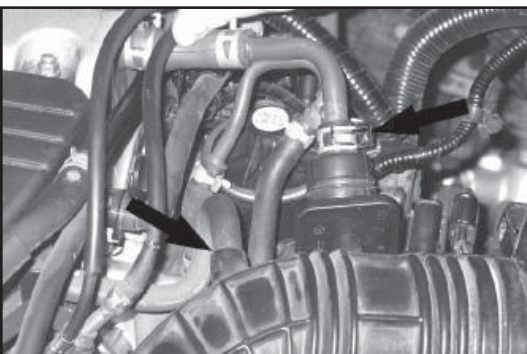

3. Depress the spring clamp and remove the crank case vent line from the vent chamber on the stock intake tube. Disconnect the vent hose from the stock intake tube.

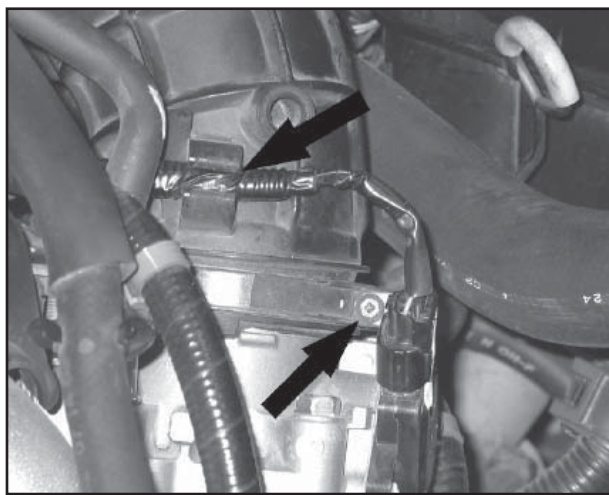

4. Loosen the hose clamp at the throttle body and unclip the throttle position sensor harness from the stock intake tube.

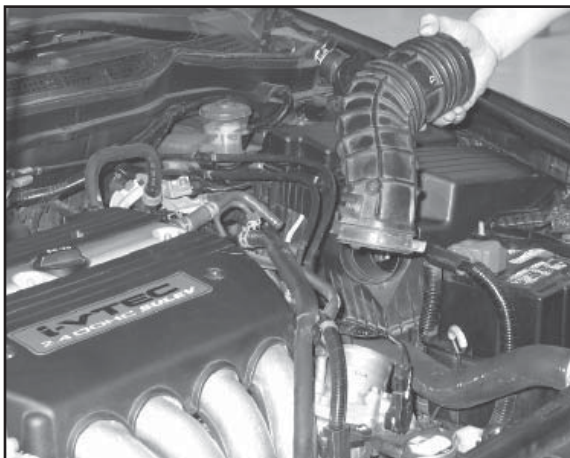

5. Pull firmly to remove the stock intake tube from the air box. Remove the intake tube from the vehicle.

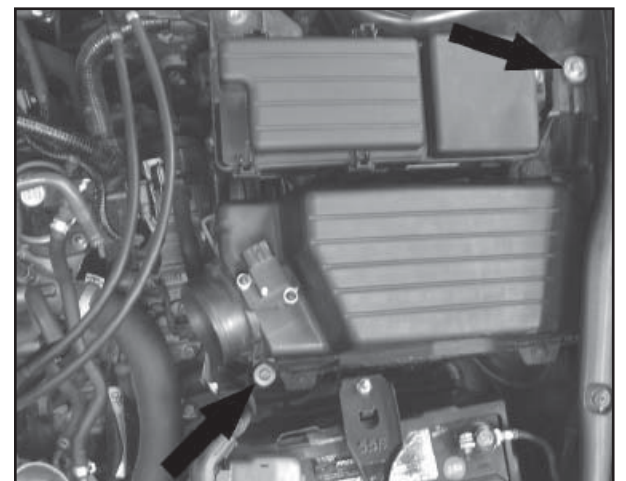

6. Remove the two bolts securing the stock air box to the vehicle.

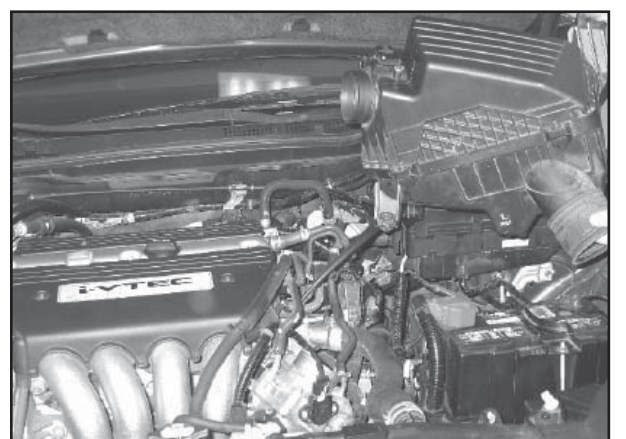

7. Unclip the wiring harness from the bottom of the stock air box and remove from the vehicle.

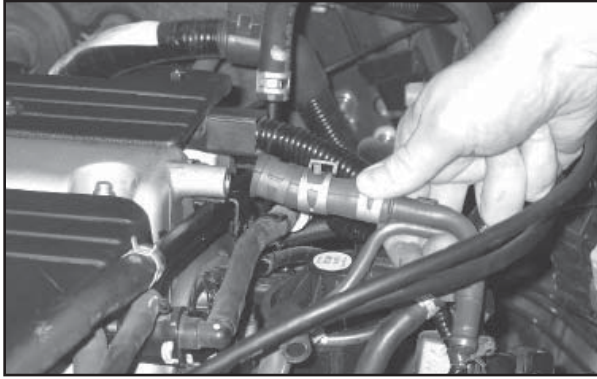

8. Depress the spring clamp and remove the crank case vent hose from the valve cover.

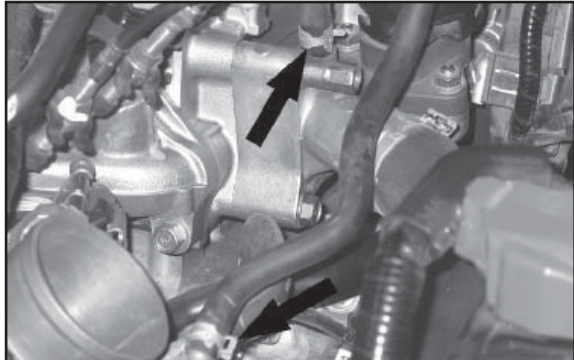

9. Depress the spring clamps on the stock coolant hose at the throttle body and thermostat housing.

**Note: Ensure the engine is completely cool before removing the coolant hose, or hot coolant will escape from the cooling system and cause injury or damage.**

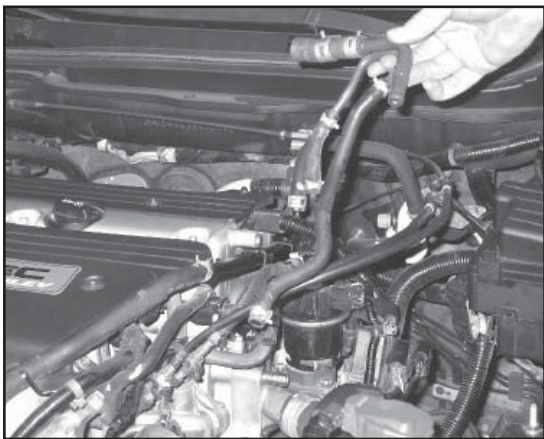

10. Remove the stock coolant hose assembly from the vehicle.

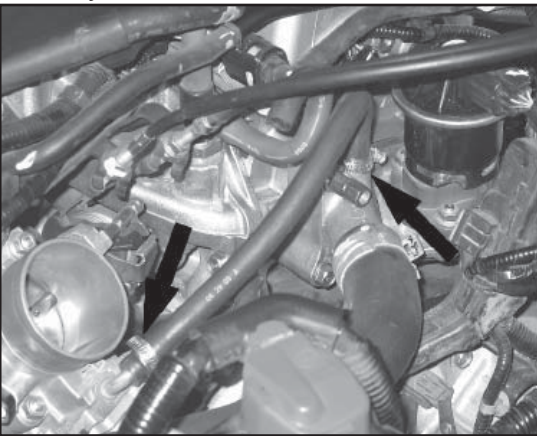

11. Install the supplied coolant hose onto the thermostat housing and throttle body. Secure with the provided clamps as shown. **Note: Replace any coolant recovered during hose removal by replenishing the recovery tank. Some trimming of the coolant hose may be necessary.**

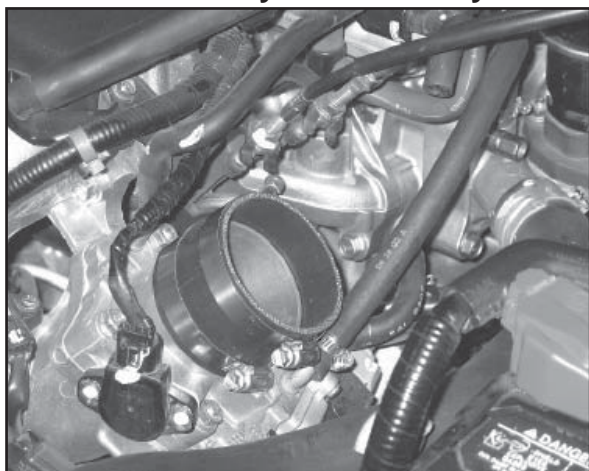

12. Install the provided silicone hose (#08440) onto the throttle body. Secure with the provided hose clamp as shown.



13. Install intake tube bracket (#06498) onto the thermostat housing with the provided hardware as shown.

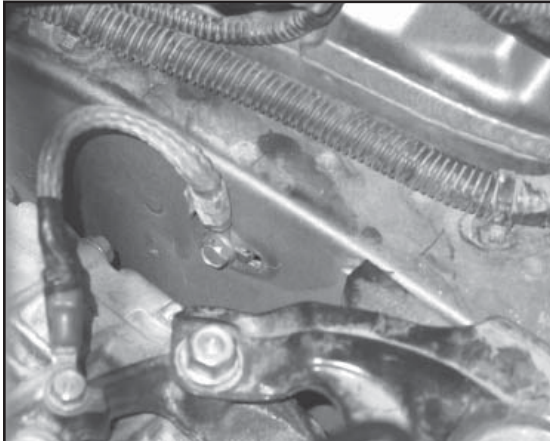

14. Remove the bolt securing the ground strap to the frame rail.

**Note: This bolt will be re-used.**

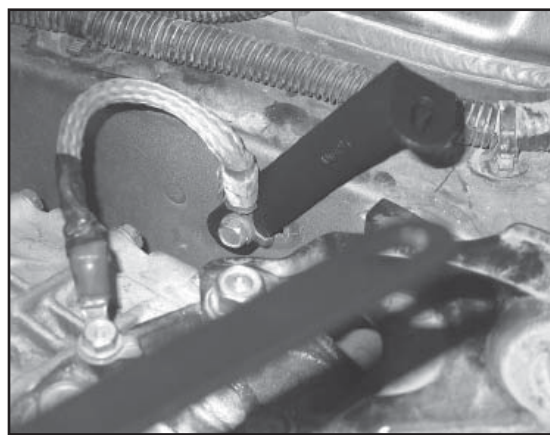

15. Install angled "L" bracket (#06497) onto the frame rail. Secure the "L" bracket and ground strap using the bolt removed in step #14.



16. Install the provided edge trim onto the heat shield as shown.

**Note: Some trimming of the edge trim may be necessary.**



17. Install "L" bracket (#06499) onto the heat shield with the provided hardware as shown.

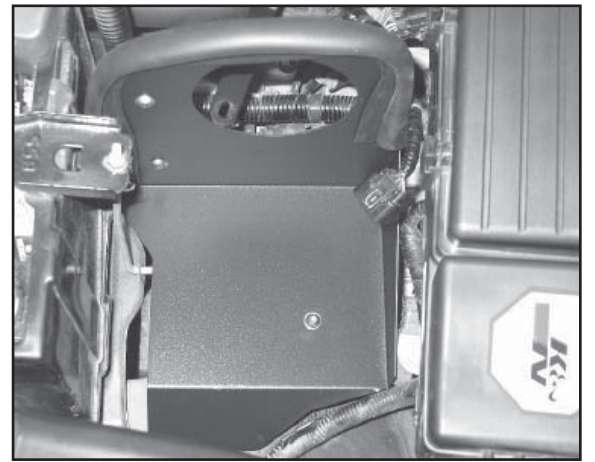

18. Install the heat shield assembly with the provided hardware as shown.

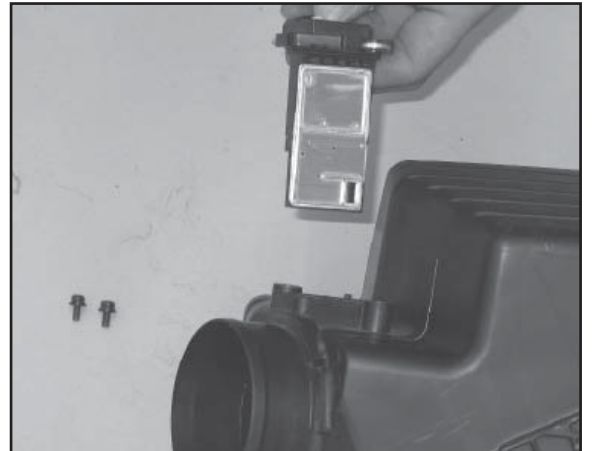

19. Remove the mass air sensor from the stock air box.



20. Depress the spring clamp and remove the crank case vent chamber from the stock intake tube.

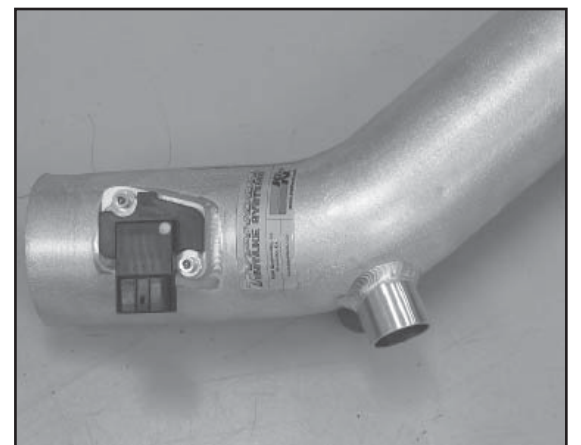

21. Install the mass air sensor into the K&N intake tube with the provided hardware as shown.

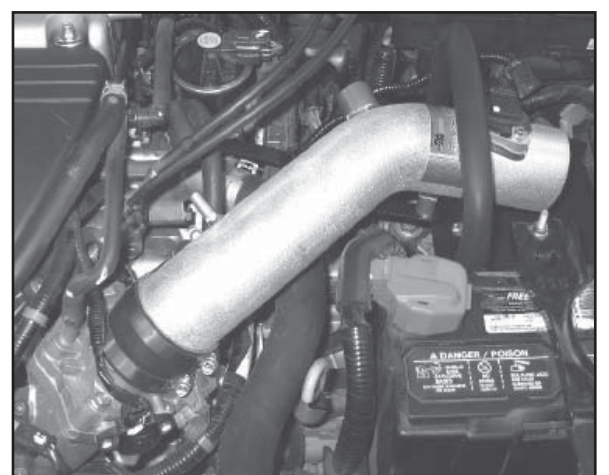

22. Install the K&N intake tube into the silicone hose at the throttle body and align with the tube mounting bracket installed in step # 13. Secure with the provided hardware and hose clamp.

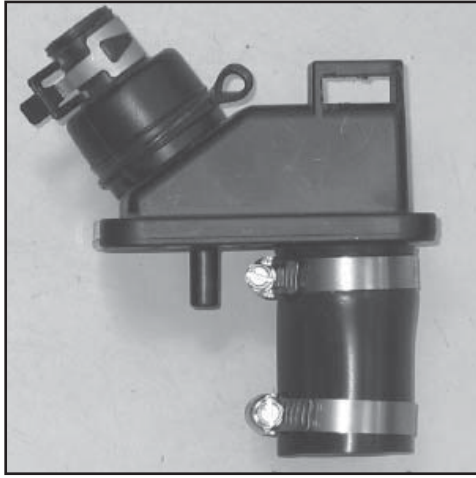

23. Install the provided silicone hose (#084074) onto the stock crank case vent chamber. Secure with the provided hose clamps as shown.

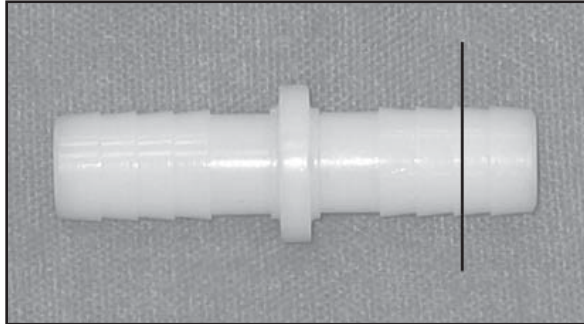

24. Cut two barbs off of the provided hose mender as shown.

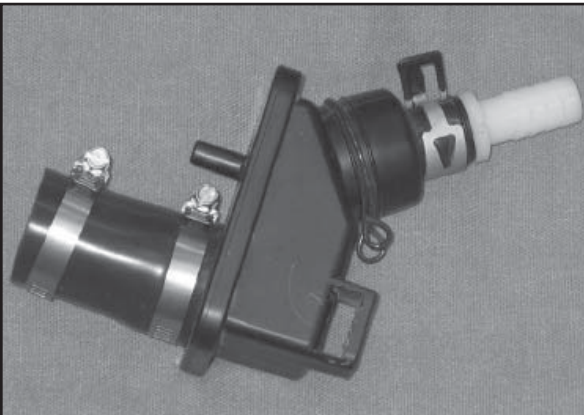

25. Insert the hose mender into the crank case vent chamber. Secure using the stock clamp removed in step # 3.

**Note: Insert the end cut in the previous step.**

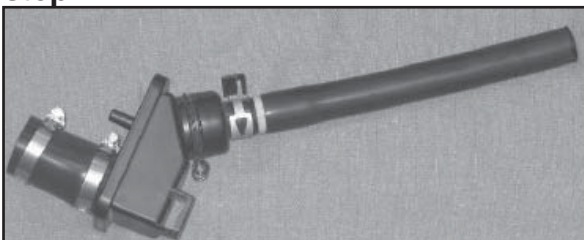

26. Install the provided silicone hose onto the hose mender as shown.

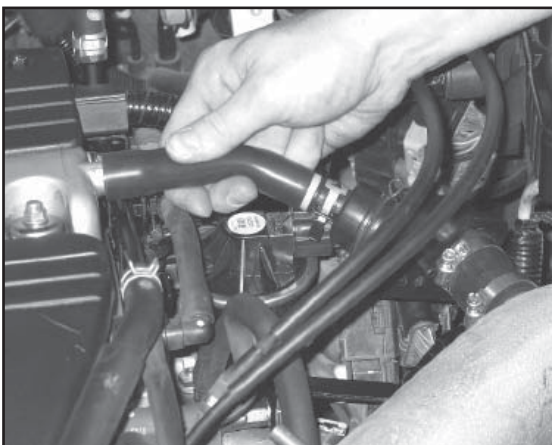

27. Install the crank case chamber assembly onto the K&N intake tube and valve cover. Secure with the provided hose clamp.

**Note: Some trimming of the 1/2" silicone hose may be necessary.**

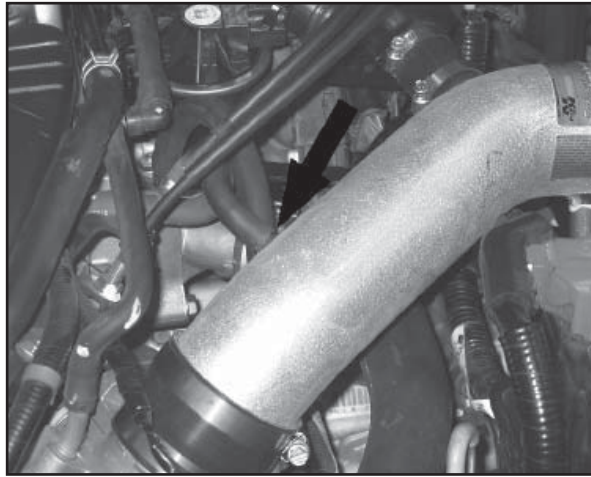

28. Install the stock vent hose onto the K&N intake tube as shown. Secure with the provided hose clamp.

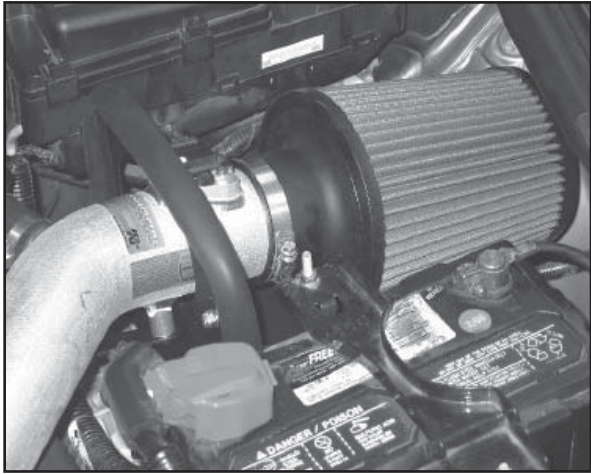

29. Install the K&N air filter onto the intake tube as shown.

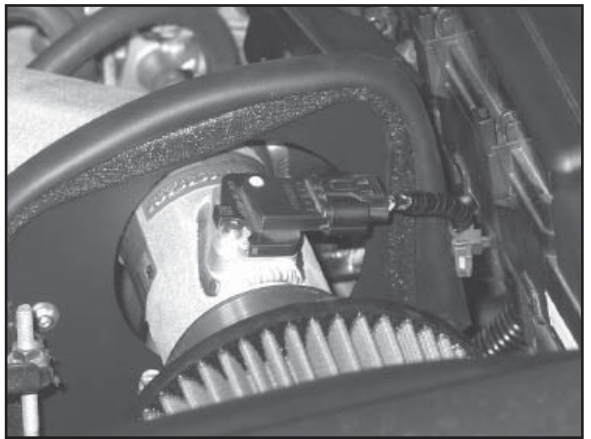

30. Re-connect the mass air sensor connector as shown.

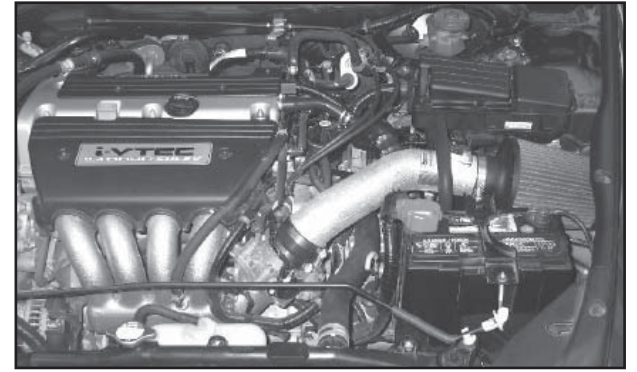

31. Reconnect the vehicle's negative battery cable. Check to ensure all hose clamps and fittings are properly tightened and positioned correctly before starting the vehicle.

32. It will be necessary for all Typhoons to be checked periodically for realignment, clearance and tightening of all connections. Failure to follow the above instructions and/or improper maintenance may void warranty.

**ROAD TESTING:**

1. Start the engine with the transmission in neutral or park, and the parking brake engaged. Listen for air leaks or odd noises. For air leaks secure hoses and connections. For odd noises, find cause and repair before proceeding. This kit will function identically to the factory system except for being louder and much more responsive.

2. Test drive the vehicle. Listen for odd noises or rattles and fix as necessary.

3. If road test is fine, you can now enjoy the added power and performance from your kit.

4. K&N suggests checking the Air Filter element periodically for excessive dirt build-up. When the element becomes covered in dirt (or once a year), service it according to the instructions on the Recharger service kit, part number 99-5000 or 99-5050.