



AIRCHARGER™

HIGH-FLOW INTAKE KITS



INSTALLATION INSTRUCTIONS

63-1537
DODGE
2011 RAM 1500
V6-3.7L

NOTE: This kit was not designed to fit vehicles with a body lift.

TOOLS NEEDED:

- 7/16" Socket
- 7/16" Wrench
- 4mm Allen
- 10mm Socket
- 13mm Socket
- 10mm Wrench
- 17mm Wrench
- Extension
- Flat Blade Screwdriver
- Ratchet

PARTS LIST:

Description	Qty.	Part #
A	1	08577
B	1	084093
C	2	08620
D	1	08402
E	1	087111
F	1	08376
G	1	078855
H	1	08180
I	1	07189
J	13	08275
K	1	07553
L	1	07149
M	1	07148
N	7	07517
O	1	07478
P	1	102487
Q	5	08386
R	2	08317
S	1	08011
T	1	08134
U	1	07702
V	1	07150
W	1	08648
X	1	RF-1040
Y	1	08175
Z	1	08005
AA	1	080544
AB	1	21715
AC	1	083103
AD	1	21680

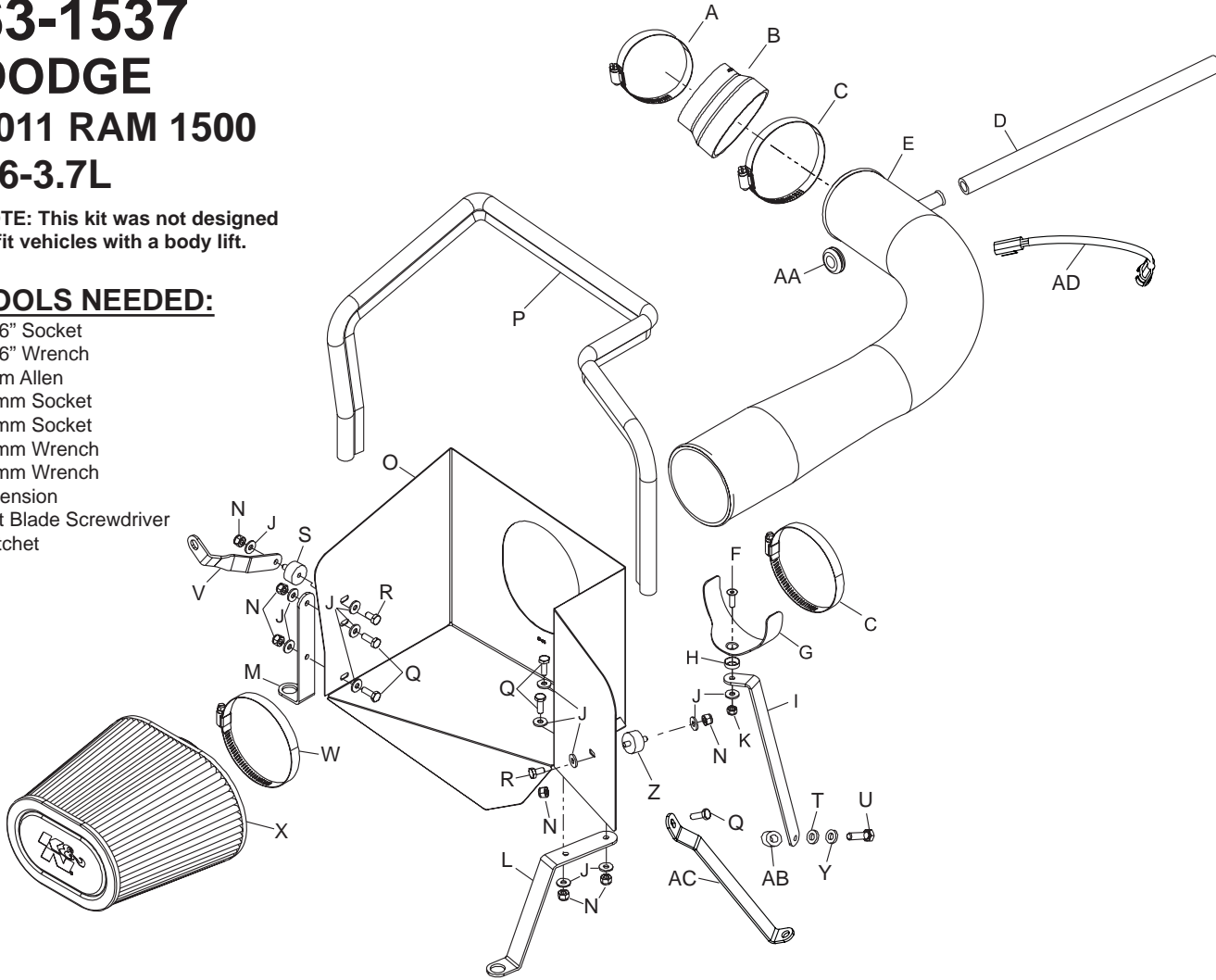

NOTE: FAILURE TO FOLLOW INSTALLATION INSTRUCTIONS AND NOT USING THE PROVIDED HARDWARE MAY DAMAGE THE INTAKE TUBE, THROTTLE BODY AND ENGINE.

TO START:

1. Turn off the ignition and disconnect the negative battery cable.

NOTE: Disconnecting the negative battery cable erases pre-programmed electronic memories. Write down all memory settings before disconnecting the negative battery cable. Some radios will require an anti-theft code to be entered after the battery is reconnected. The anti-theft code is typically supplied with your owner's manual. In the event your vehicles' anti-theft code cannot be recovered, contact an authorized dealership to obtain your vehicles anti-theft code.



2. Loosen the hose clamp that connects the intake tube to the resonator box then remove the intake tube.

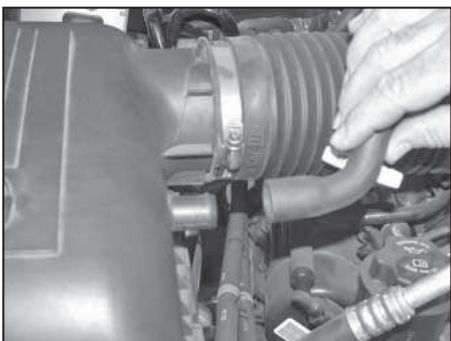

2a. On vehicles equipped, disconnect the crankcase vent from the airbox as shown.

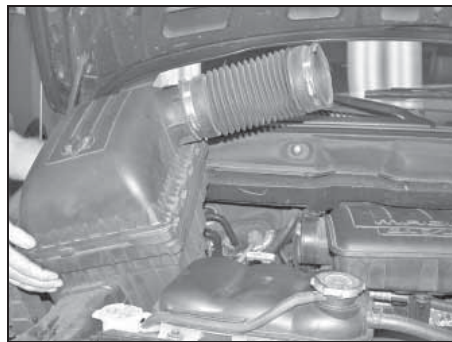

3. Lift firmly to release the airbox from the mounting studs, then remove completely.

NOTE: K&N Engineering, Inc., recommends that customers do not discard factory air intake.

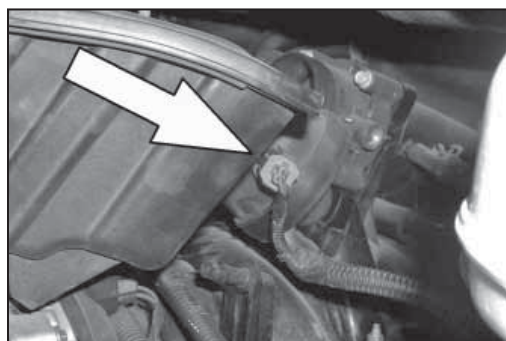

4. Disconnect the inlet air temperature sensor electrical connection.

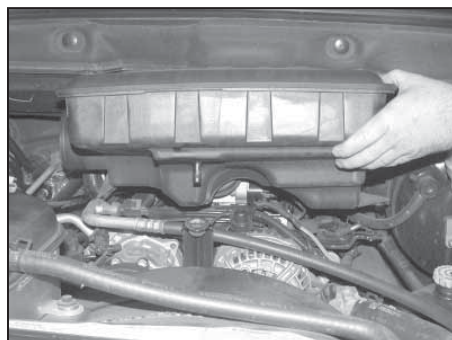

5. Pull up firmly to release the resonator from the engine.

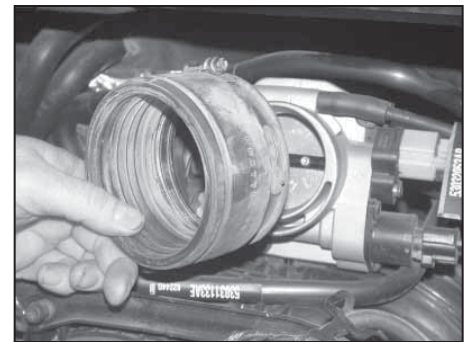

6. Loosen hose clamp that retains the rubber hose to the throttle body, then remove as shown.

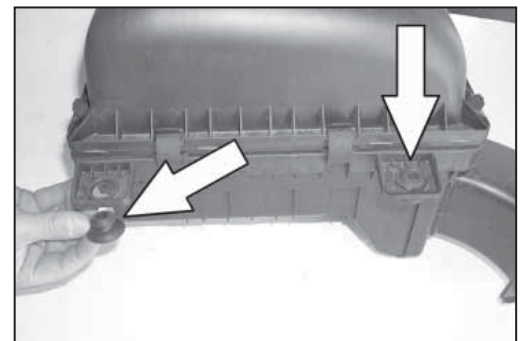

7. Remove the two rubber bushings from the factory airbox as shown.

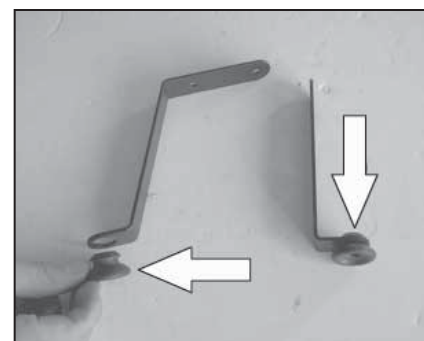

8. Install the two rubber bushings that were removed in the previous step into the provided brackets as shown.

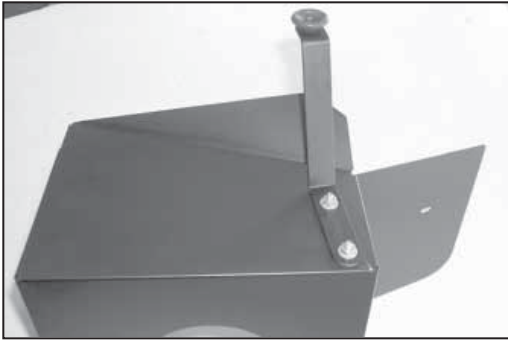

9. Install the large "Z" bracket onto the heat shield with the provided hardware. Do not tighten completely at this time.

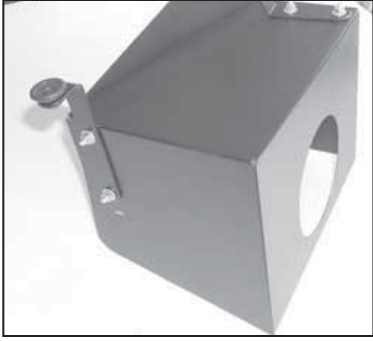

10. Install the "L" bracket onto the heat shield with the provided hardware. Do not tighten completely at this time.



11. Install the rubber mounted stud into the provided bracket as shown.

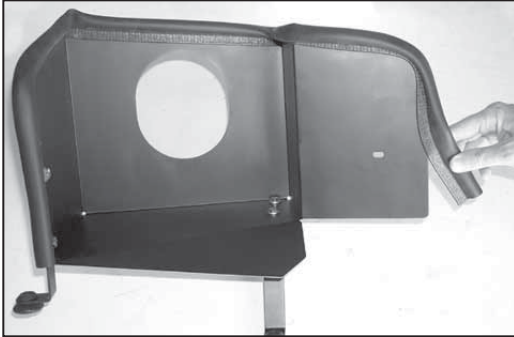

12. Install the provided edge trim onto the heat shield.

NOTE: Some trimming of the edge trim will be necessary.

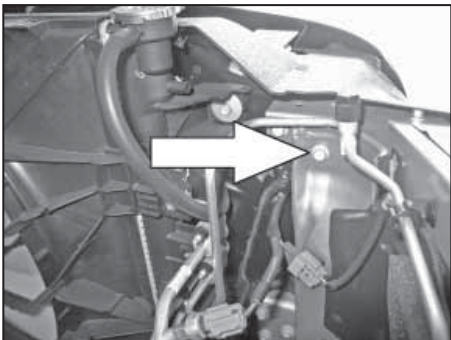

13. Remove the bolt shown from the radiator core support.

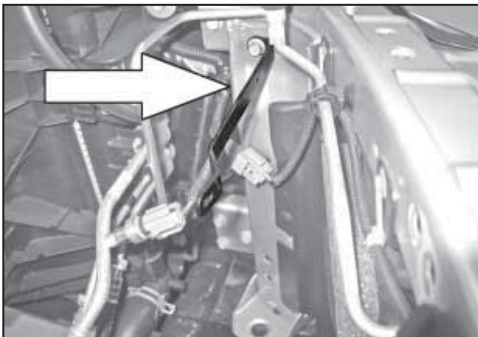

14. Install the provided heat shield mounting bracket onto the radiator core support using the bolt removed in the previous step.

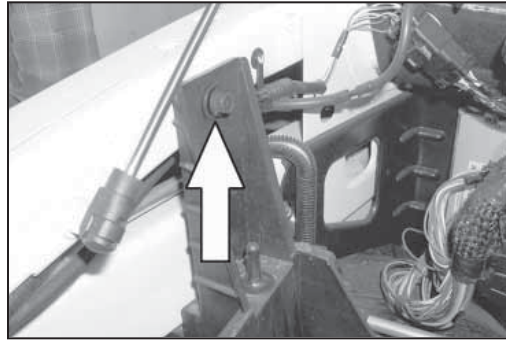

15. Remove the 8mm bolt that retains the airbox mount.

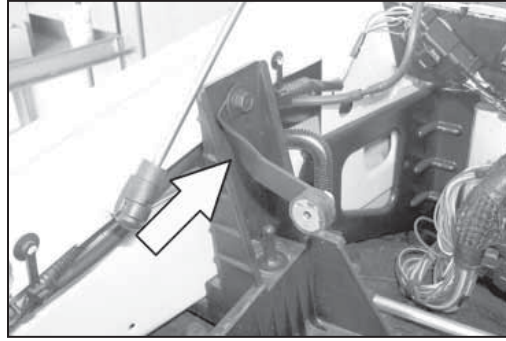

16. Install the twisted "L" bracket with the bolt that was removed in step 15. Do not tighten bolt completely.



17. Assemble the saddle bracket assembly as shown.

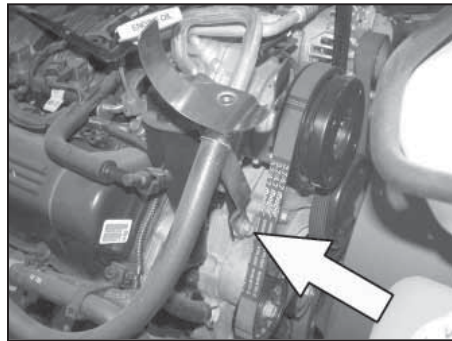

18. Install the saddle bracket assembly onto the belt tensioner using the provided spacer and hardware.

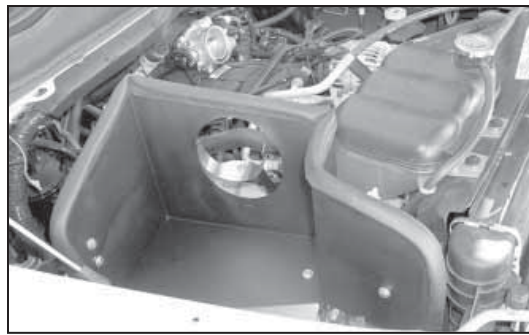

19. Install the heat shield onto the factory airbox studs then mount to the previously installed brackets.



20. Install the provided silicone hose onto the K&N® intake tube with the provided hose clamp as shown.

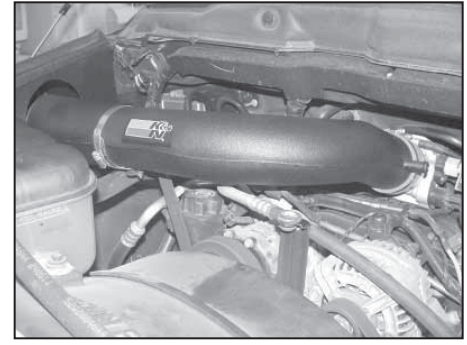

21. Install the intake tube onto the throttle body and saddle clamp and secure with the provided hose clamps as shown.



22. On models that come equipped with temp sensors, remove the air temp sensor from the resonator box as shown.

NOTE: Take care removing the air temperature sensor as it is very fragile.



23. On vehicles equipped with an air temperature sensor, hold up the air temperature sensor wiring harness to the intake tube and mark the intake tube for drill point.

NOTE: The inlet air temperature sensor may be located on the driver's side of the vehicle, using the provided harness extension will aid in locating the inlet air temperature sensor in the intake tube.



24. Drill a 7/8" hole in the K&N® intake tube at the drill point.



25. Install the provided grommet into the intake tube as shown.



26. Remove the O-ring from the air temp. sensor as shown.



27. Install the air temp sensor into the K&N® intake tube as shown.

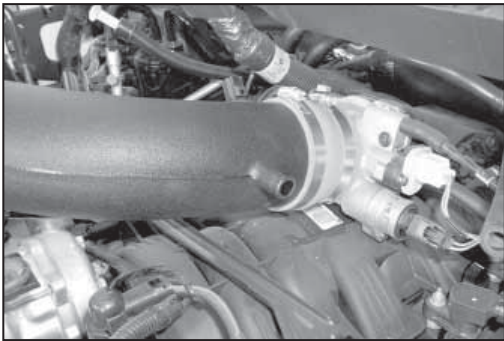

28. Install the intake tube onto the throttle body with the provided hose clamp.

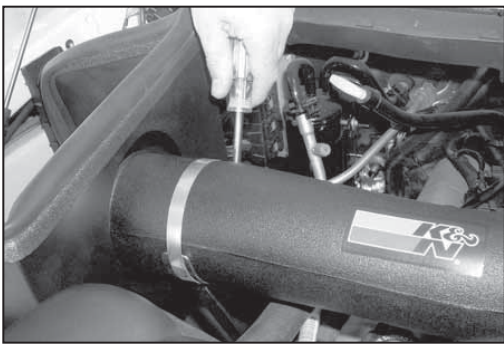

29. Using the provided hose clamp, secure the K&N® intake tube to the saddle bracket assembly as shown.



30. On models equipped with a air temp sensor, reconnect the electrical connection as shown.
NOTE: Due to manufacturing tolerances, it may be necessary to use the provided extension harness to connect the inlet air temperature sensor electrical connection.



31. Remove the crankcase vent tube from the passenger side valve cover. Then remove the rubber elbow from the tube, and install the provided straight silicone hose. Then reinstall the crankcase vent tube so that it runs behind the throttle body .

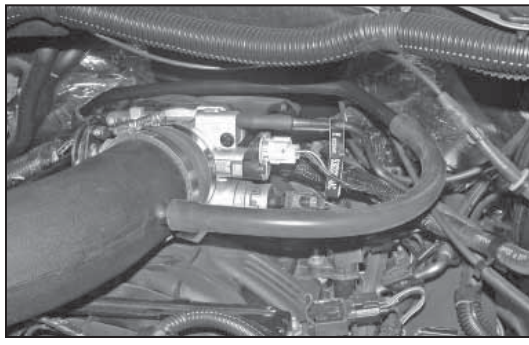

32. Connect the modified crankcase vent hose to the K&N® intake tube as shown.

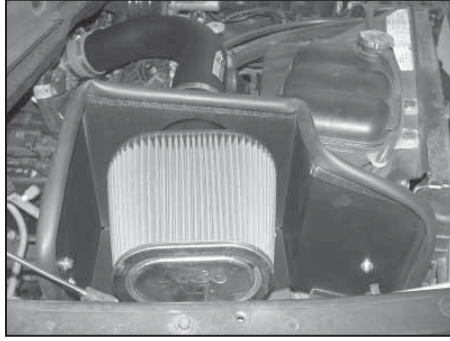

33. Install the K&N® air filter onto the K&N® intake tube as shown and secure with the hose clamp.
NOTE: Drycharger® air filter wrap; part number RF-1034DK is available to purchase separately. To learn more about Drycharger® filter wraps or look up color availability please visit <http://www.knfilters.com>®.

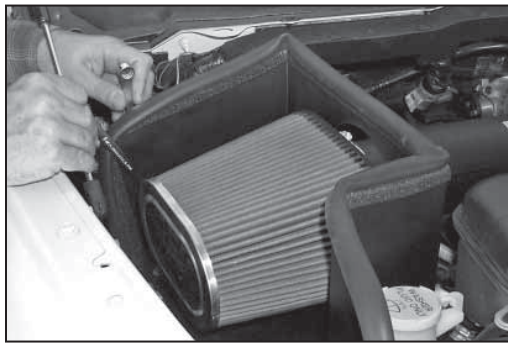

34. Align the heat shield for best clearance then tighten all the brackets.

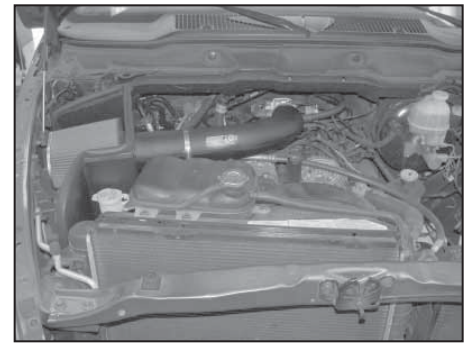

35. Reconnect the vehicle's negative battery cable. Double check to make sure everything is tight and properly positioned before starting the vehicle.

36. It will be necessary for all K&N® high flow intake systems to be checked periodically for realignment, clearance and tightening of all connections. Failure to follow the above instructions or proper maintenance may void warranty.

ROAD TESTING:

1. Start the engine with the transmission in neutral or park, and the parking brake engaged. Listen for air leaks or odd noises. For air leaks secure hoses and connections. For odd noises, find cause and repair before proceeding. This kit will function identically to the factory system except for being louder and much more responsive.
2. Test drive the vehicle. Listen for odd noises or rattles and fix as necessary.
3. If road test is fine, you can now enjoy the added power and performance from your kit.
4. K&N Engineering, Inc., suggests checking the air filter element periodically for excessive dirt build-up. When the element becomes covered in dirt (or once a year), service it according to the instructions on the Recharger® service kit, part number 99-5050 or 99-5000.

STREET LEGAL IN MOST STATES

**NOT LEGAL FOR USE IN CA & OTHER STATES
ADOPTING CA EMISSIONS STANDARDS**

See our catalog or knfilters.com for CARB status on each part for a specific vehicle

* FREE K&N® decal To register your warranty, please see us online at knfilters.com/register. FREE K&N® decal *