



INTAKE SYSTEMS FOR VEHICLES LISTED ARE 50 STATE LEGAL. SEE KNFILTERS.COM FOR CARB STATUS ON EACH PART FOR A SPECIFIC VEHICLE.

INSTALLATION INSTRUCTIONS

57-3057

CHEVROLET / GMC

2007 SILVERADO HD CLASSIC

2007 SIERRA HD CLASSIC

2005-06 SILVERADO HD

2005-06 SIERRA HD

V8-6.6L TURBO DIESEL

TOOLS NEEDED:

- ratchet
- extension
- 10mm socket
- 10mm wrench
- 2.5mm allen wrench
- 3.0mm allen wrench
- flat blade screwdriver
- T20 TORX wrench

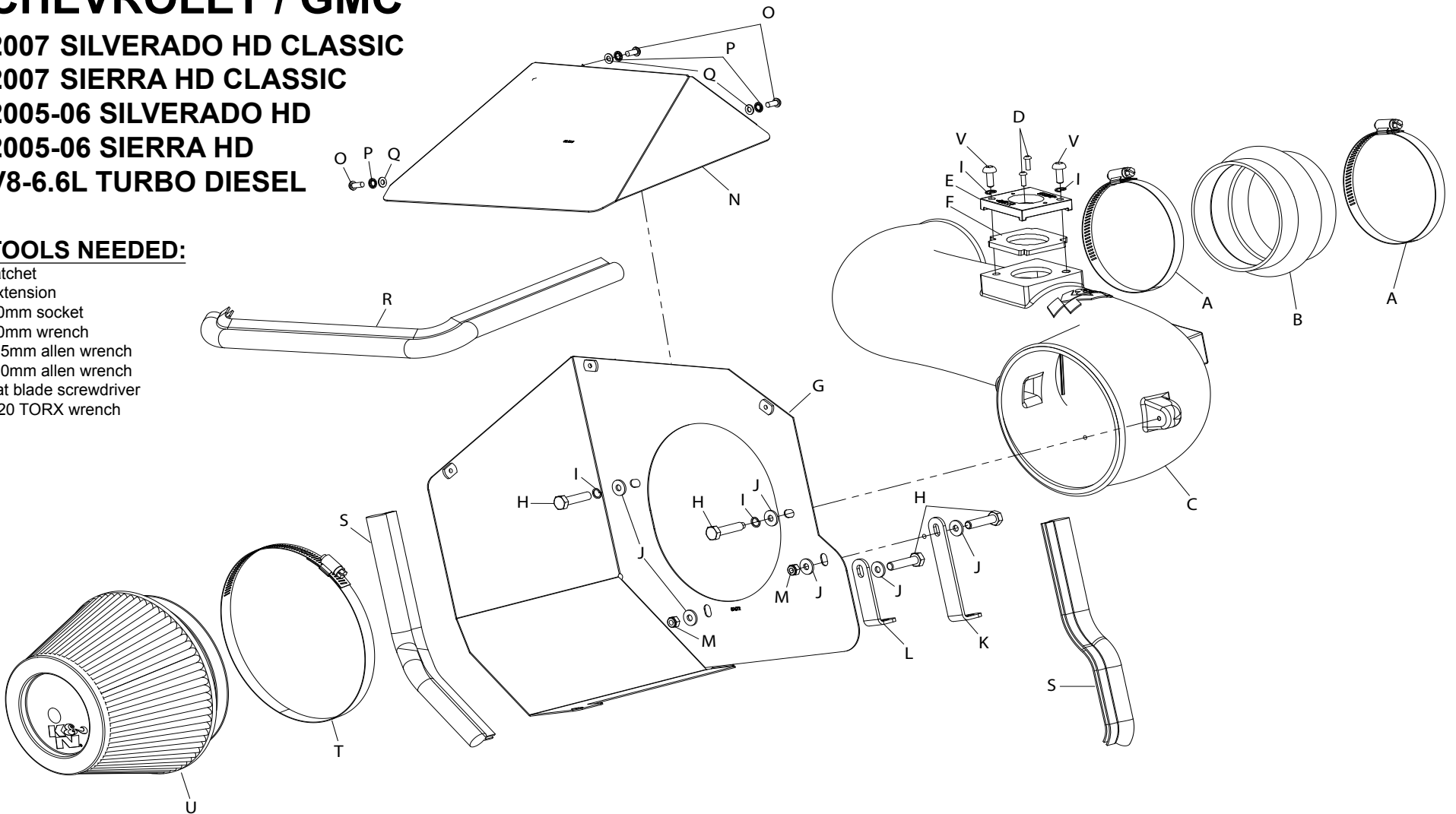

PARTS LIST:

Description	Qty.	Part #	Description	Qty.	Part #	Description	Qty.	Part #
A Hose Clamp #64	2	08648	I Washer; 1/4" Lock, Zn	4	08198	Q Washer; 5mm Flat, SS	3	08212
B Hose; 5.0"odx4.19"idx3"L, Hump	1	08617	J Washer; 1/4"ID X 5/8"OD	6	08275	R Edge Trim	1	102476
C Intake Tube	1	087186-1	K Bracket; L-Bend	1	070952	S Edge Trim	2	102468
D Screw; M4-.7X12, B/H SS	2	07726	L Bracket; Short "L"	1	07805	T Hose Clamp #104	1	08697
E Adapter; nylon 6/6	1	27317	M Nut; 6mm Nylock, Hex Head	2	07553	U Air Filter	1	RC-5179
F Gasket; 3/16 poron	1	09074	N Heat Shield	1	07673	V Bolt; M6X1.00X16MM, SS	2	07730
G Heat Shield	1	07672	O Bolt; M5-0.8 X 12mm B/H, SS	3	07734			
H Bolt; M6-1.00 X 16mm Hex Hd.	4	07703	P Washer; 5mm Star Cut Lock	3	07724			

NOTE: FAILURE TO FOLLOW INSTALLATION INSTRUCTIONS AND NOT USING THE PROVIDED HARDWARE MAY DAMAGE THE INTAKE TUBE, THROTTLE BODY AND ENGINE.

TO START:

1. Turn off the ignition and disconnect the negative battery cable.

NOTE: Disconnecting the negative battery cable erases pre-programmed electronic memories. Write down all memory settings before disconnecting the negative battery cable. Some radios will require an anti-theft coded to be entered after the battery is reconnected. The anti-theft code is typically supplied with your owner's manual. In the event your vehicles' anti-theft code cannot be recovered, contact an authorized dealership to obtain your vehicles anti-theft code.



2. Depress the locking tab on the mass air sensor electrical connector, and then disconnect the electrical connection as shown.



3. Loosen the hose clamps which secure the intake tube to the intake manifold and air box, then remove the intake tube from the vehicle.



4. Lift up on the intake assembly to release from the mounting grommets and then remove the assembly from the vehicle as shown.

NOTE: K&N Engineering, Inc., recommends that you do not discard your factory air intake.



5. Install the silicone hose (08617) onto the intake manifold and secure with the provided hose clamp as shown.

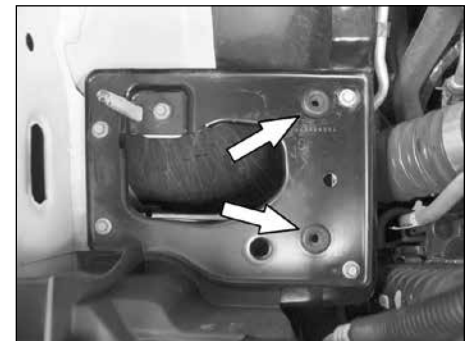

6. Remove the two mounting grommets shown from the mounting plate.

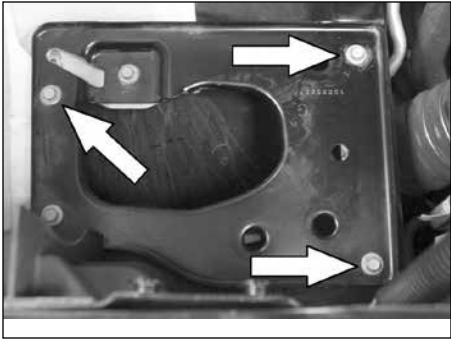

7. Remove the three bolts shown which secure the mounting plate.



8. Using the "TORX" T20 wrench, remove the two bolts, which secure the mass air sensor to the air filter housing and then remove the mass air sensor.



9. Remove the air filter restriction gauge and stock grommet from the air filter housing as shown.

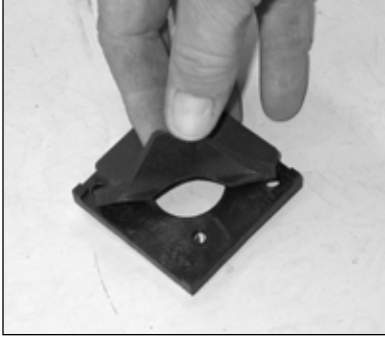

10. Attach the provided gasket onto the back of the K&N® mass air adapter as shown.

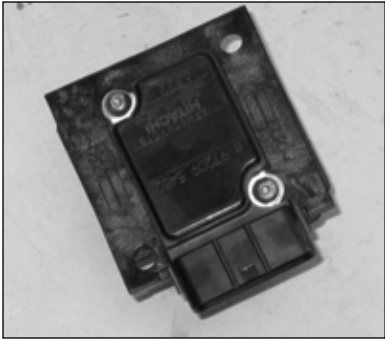

11. Install the mass air sensor into the K&N® mass air adapter and secure with the provided hardware.



11a. Install the mass air sensor assembly into the K&N® intake tube and secure with the provided hardware.

NOTE: Be sure to install the mass air sensor in the correct direction. The opening should be pointed towards the filter end of the tube.



12. Install the factory grommet and filter restriction gauge into the K&N® intake tube as shown.

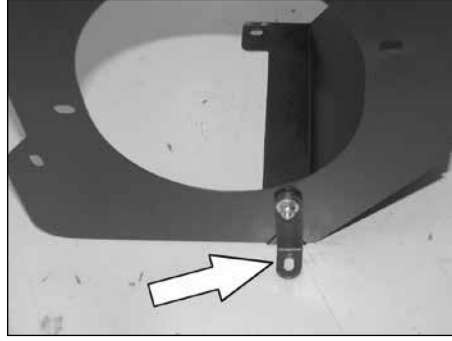

13. Install the "L" bracket (07805) onto the heat shield as shown with the provided hardware as shown.

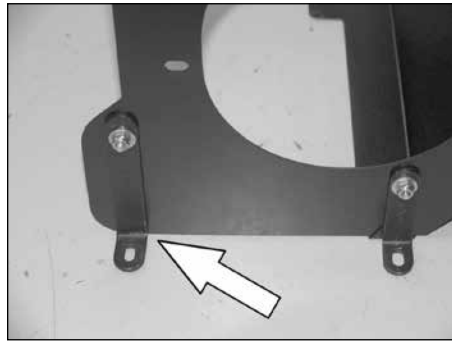

14. Install the "L" bracket (070952) onto the heat shield as shown with the provided hardware as shown.

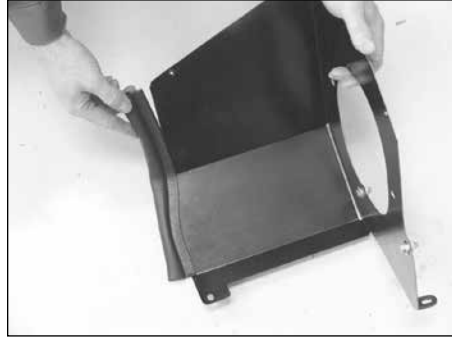

15. Install the edge trim onto the heat shield as shown.

NOTE: Some trimming of the edge trim will be necessary.

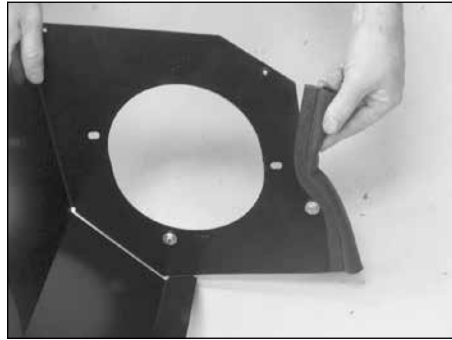

16. Install the edge trim onto the heat shield as shown.

NOTE: Some trimming of the edge trim will be necessary.

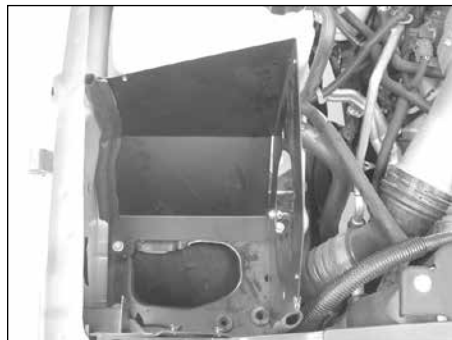

17. Install the heat shield onto the air box mounting plate and secure with the factory bolts removed in step #7.

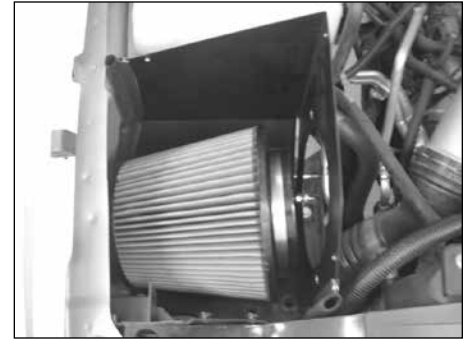

18. Set the K&N® air filter into the heat shield as shown.



19. Secure the K&N® intake tube to the silicone hose at the throttle body with the hose clamp provided and to the heat shield with the provided hardware.



20. Install the K&N® air filter onto the K&N® intake tube and secure with the provided hose clamp.



21. Install the edge trim onto the heat shield lid as shown.

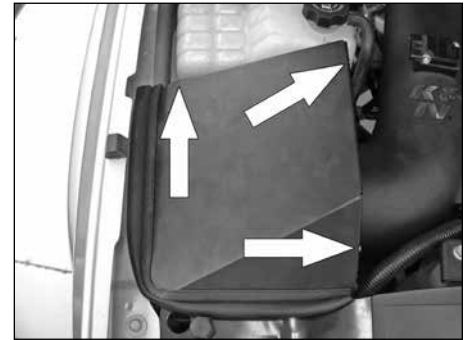

22. Install the heat shield lid onto the heat shield and secure with the three 5mm button head allen bolts provided.



23. Reconnect the mass air sensor electrical connection.



24. Reconnect the vehicle's negative battery cable. Double check to make sure everything is tight and properly positioned before starting the vehicle.

25. The C.A.R.B. exemption sticker, (attached), must be visible under the hood so that an emissions inspector can see it when the vehicle is required to be tested for emissions. California requires testing every two years, other states may vary.

26. **NOTE:** Most General Motors vehicles have the Vehicle Emissions Certification Information (VECI) label affixed to the air filter box. In order to be compliant with California emissions laws, the label **MUST** remain in the engine compartment. If the Vehicle Emission Control Information label is removed during modification, a new replacement label must be obtained and installed in a readily visible position in the engine compartment. The label shall not be affixed to any equipment which is easily detached from the vehicle. We recommend that the label is affixed to the underside of the hood adjacent to the hood latch. The label is Vehicle Identification Number dependent and can be ordered from the vehicle dealership. In order to receive the proper decal please bring your VIN with you. Failure to have the VECI under the hood may result in failure of a pre-registration smog test.

26. It will be necessary for all K&N® high flow intake systems to be checked periodically for realignment, clearance and tightening of all connections. Failure to follow the above instructions or proper maintenance may void warranty.

ROAD TESTING:

1. Start the engine with the transmission in neutral or park. Listen for air leaks or odd noises. For air leaks secure hoses and connections. For odd noises, find cause and repair before proceeding. This kit will function identically to the factory system except for being louder and much more responsive.

2. Test drive the vehicle. Listen for odd noises or rattles and fix as necessary.

3. If road test is fine, you can now enjoy the added power and performance from your kit.

4. K&N Engineering, Inc., suggests checking the air filter element periodically for excessive dirt build-up. When the element becomes covered in dirt (or once a year), service it according to the instructions on the Recharger® service kit, part number 99-5050 or 99-5000.

INTAKE SYSTEMS FOR VEHICLES LISTED ARE 50 STATE LEGAL. SEE KNFILTERS.COM FOR CARB STATUS ON EACH PART FOR A SPECIFIC VEHICLE.

* FREE K&N® decal To register your warranty, please see us online at knfilters.com/register. FREE K&N® decal *

• 1455 CITRUS ST., P.O. BOX 1329, RIVERSIDE, CA., U.S.A. 92502 • TECH SERVICE 800-858-3333 • FAX 951-826-4001
• e-mail: tech@knfilters.com • WWW: <http://www.knfilters.com>