



INTAKE SYSTEMS FOR VEHICLES LISTED ARE 50 STATE LEGAL. SEE KNFILTERS.COM FOR CARB STATUS ON EACH PART FOR A SPECIFIC VEHICLE.

INSTALLATION INSTRUCTIONS

**57-2558
LINCOLN
2000-02 Navigator
V8-5.4L DOHC**

NOTE: This kit was not designed to fit vehicles with a body lift.

TOOLS NEEDED:

- Flat Blade Screwdriver
- 4mm Allen
- 10mm Wrench
- 9/16 Socket
- 13mm Socket
- 10mm Socket
- 8mm Socket
- 5/8" Drill Bit
- Drill Motor
- Extension
- Ratchet

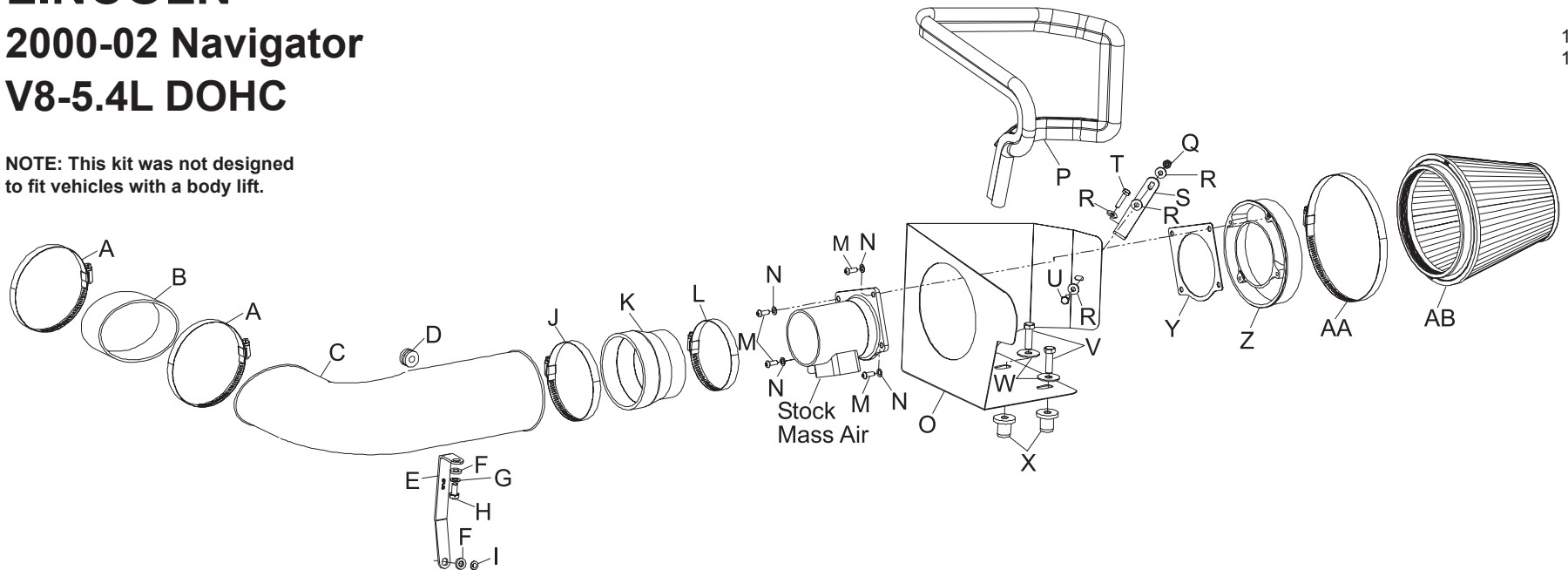

PARTS LIST:

Description	Qty.	Part #	Description	Qty.	Part #	Description	Qty.	Part #
A hose clamp #72	2	08671	K silicone step hose	1	08050	U bolt 6mm x 16mm	1	07703
B silicone hose; 4.5" id x 1.75" l	1	08623	L hose clamp #56	1	08620	V bolt 3/8 x 1.125	2	07779
C intake tube (DH)	1	087103	M bolt m6 buttonhead allen	4	07730	W fender washer	2	08126
D grommet, 3/8" id	1	08100	N washer 1/4" split lock	4	08198	X insert; 3/8" threaded	2	08163
E bracket "L" long	1	07169	O heat shield	1	07483	Y gasket; mass air sensor	1	09984
F washer 5/16" flat	2	08276	P edge trim 55"	1	102480	Z filter adapter #250	1	08785
G washer 8mm wave	1	08239	Q nut 6mm nylock	1	07553	AA hose clamp #104	1	08697
H bolt 8mm x 16mm	1	07844	R washer 1/4" id x 5/8" od flat	4	08275	AB air filter	1	RC-5046
I nut 8mm nylock	1	07542	S bracket "L" short	1	070952			
J hose clamp #64	1	08645	T bolt 6mm x 25mm	1	07704			

NOTE: FAILURE TO FOLLOW INSTALLATION INSTRUCTIONS AND NOT USING THE PROVIDED HARDWARE MAY DAMAGE THE INTAKE TUBE, THROTTLE BODY AND ENGINE.

TO START:

1. Turn off the ignition and disconnect the negative battery cable.
NOTE: Disconnecting the negative battery cable erases pre-programmed electronic memories. Write down all memory settings before disconnecting the negative battery cable. Some radios will require an anti-theft code to be entered after the battery is reconnected. The anti-theft code is typically supplied with your owner's manual. In the event your vehicles' anti-theft code cannot be recovered, contact an authorized dealership to obtain your vehicles anti-theft code.

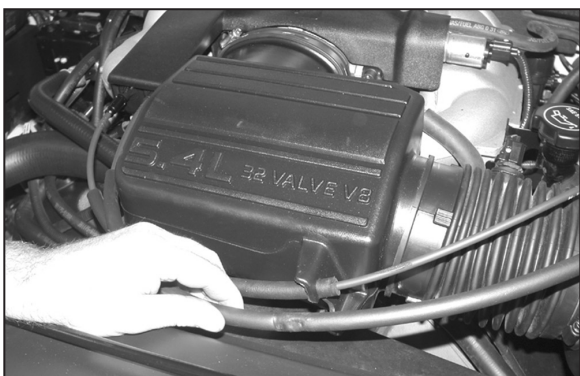

2. Unhook and remove speed control cable and throttle cable from the stock intake tube.



3. On vehicles equipped with air temp sensor, disconnect wire connector from air temp sensor.

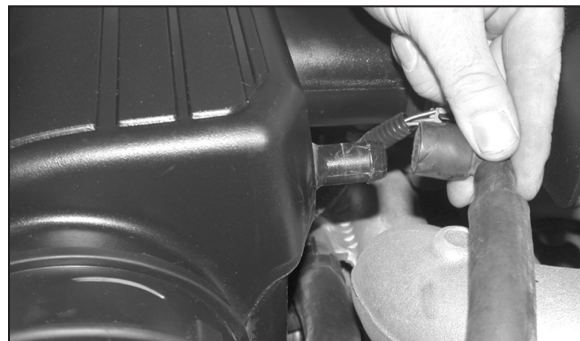

4. Disconnect crank case vent from stock intake tube.



5. Loosen hose clamp at the throttle body.



6. Detach the stock intake tube from the throttle body and lift up on the air cleaner assembly to release it from its retaining grommets.

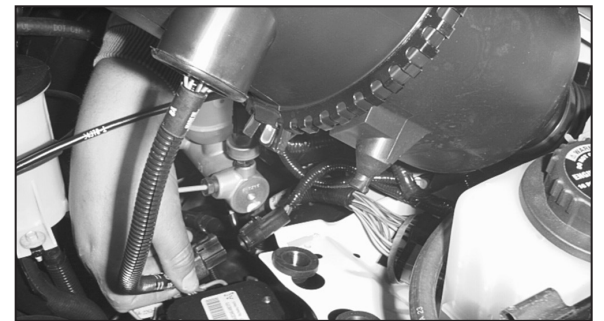

7. Disconnect the secondary mass air sensor electrical connection.



8. Remove the entire stock intake assembly.
NOTE: K&N Engineering, Inc., recommends that customers do not discard factory air intake.



9. Open the air cleaner assembly and isolate the mass air sensor assembly.



10. Slide the rubber grommet back and disconnect the primary mass air sensor electrical connection, using a flat blade screwdriver.

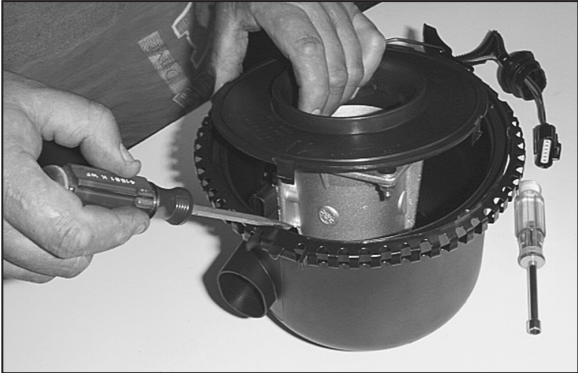

11. Using a flat blade screwdriver, push in and release the four clips that retain the mass air sensor retaining plate.



12. Using a pair of small vise grips or pliers, hold the stud while using a 10mm wrench to loosen the nuts, then remove the mass air sensor from the retaining plate.



13. Remove the two air box mounting grommets from vehicle as shown.



14. Install edge trim onto heat shield as shown. Trim if needed.



15. Remove the 6mm bolt that retains the cruise control onto vehicle.



16. Install the provided "L" bracket (070952) onto heat shield as shown.

NOTE: Install a washer between heat shield and bracket.

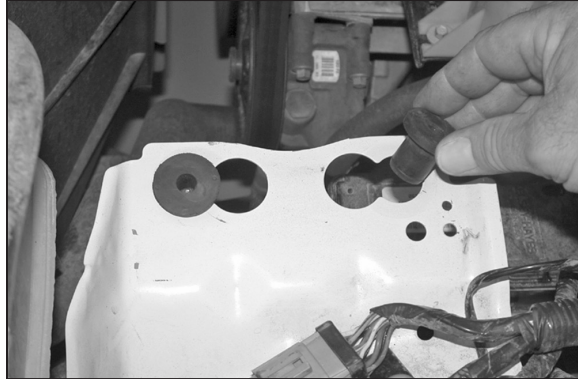

17. Install the two nut inserts onto the air box mounting tray as shown.

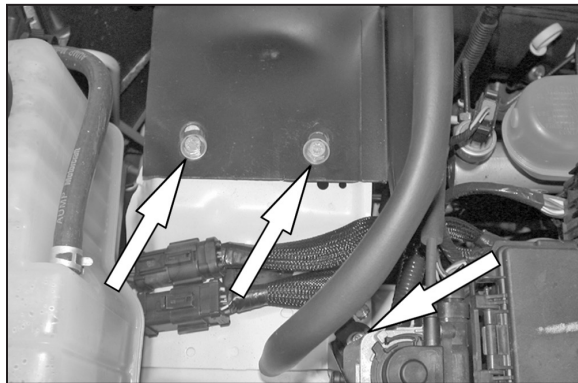

18. Install heatshield as shown with provided hardware.



19. On vehicles equipped with an air temp sensor. Drill a 5/8" hole at the drill point indicated on the K&N® intake tube.



20. Install the provided grommet into the new intake tube as shown.

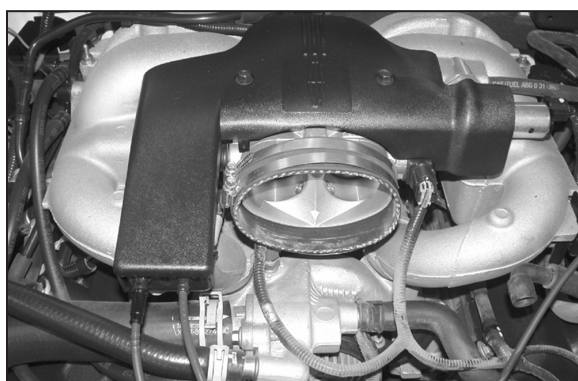

21. Install the silicone hose (08623) onto throttle body with provided hose clamps as shown.



22. Install the provided bracket (07169) onto the K&N® intake tube with hardware provided.



23. Install the new K&N® intake tube onto the silicone hose.

NOTE: Intake tube bracket should pass behind coolant hose and in front of engine wire harness, then install onto threaded stud on front engine. Then secure with provided hardware.

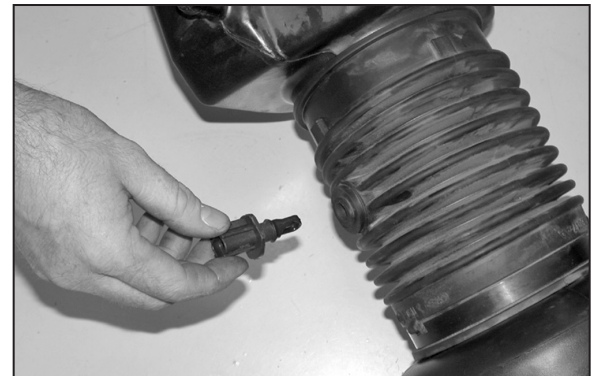

24. On vehicles equipped with air temp sensor, remove the air temp sensor from the stock intake tube.



25. Install the air temp sensor into the K&N® intake tube, reconnect the air temp electrical connection and install crank case vent onto the vent port.

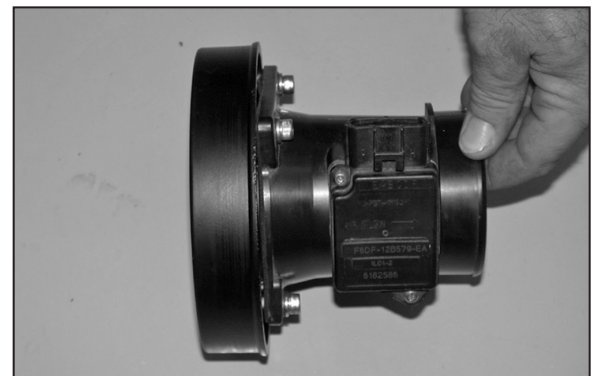

26. Attach the mass air adapter to the mass air sensor using the gasket and provided hardware as shown.

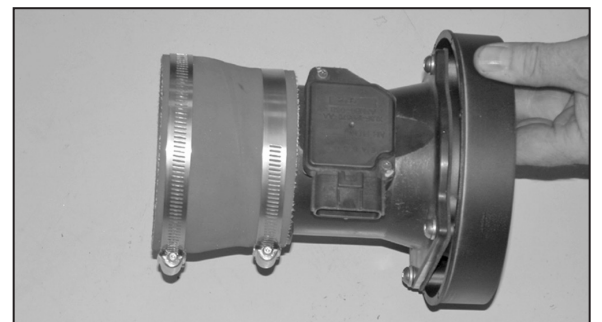

27. Install the silicone hose (08050) onto the mass air assembly with provided hose clamp as shown.

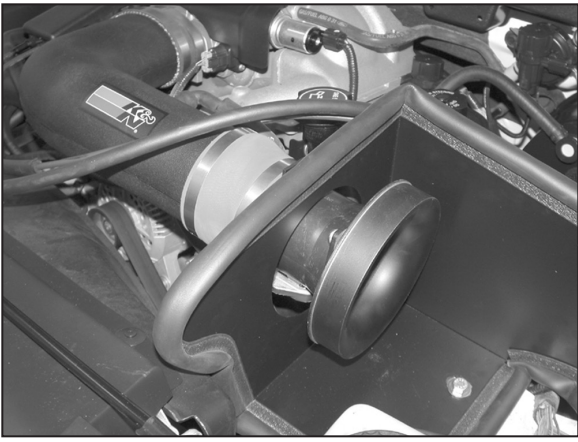

28. Install the mass air sensor assembly onto the new intake tube as shown.



29. Reconnect the primary and secondary mass air electrical connection.



30. Install the K&N® air filter onto the mass air sensor and secure it with the provided hose clamp.
NOTE: Drycharger® air filter wrap; part # RC-5046DK is available to purchase separately. To learn more about Drycharger® filter wraps or look up color availability please visit <http://www.knfilters.com>®.



31. Reconnect the vehicle's negative battery cable. Double check to make sure everything is tight and properly positioned before starting the vehicle.

32. The C.A.R.B. exemption sticker, (attached), must be visible under the hood so that an emissions inspector can see it when the vehicle is required to be tested for emissions. California requires testing every two years, other states may vary.

33. It will be necessary for all K&N® high flow intake systems to be checked periodically for realignment, clearance and tightening of all connections. Failure to follow the above instructions or proper maintenance may void warranty.

ROAD TESTING:

1. Start the engine with the transmission in neutral or park, and the parking brake engaged. Listen for air leaks or odd noises. For air leaks secure hoses and connections. For odd noises, find cause and repair before proceeding. This kit will function identically to the factory system except for being louder and much more responsive.

2. Test drive the vehicle. Listen for odd noises or rattles and fix as necessary.

3. If road test is fine, you can now enjoy the added power and performance from your kit.

4. K&N Engineering, Inc., requires cleaning the intake system's air filter element every 100,000 miles. When used in dusty or off-road environments, our filters will require cleaning more often. We recommend that you visually inspect your filter once every 25,000 miles to determine if the screen is still visible. When the screen is no longer visible some place on the filter element, it is time to clean it. To clean and re-oil, purchase our filter Recharger® service kit, part number 99-5050 or 99-5000 and follow the easy instructions.

INTAKE SYSTEMS FOR VEHICLES LISTED ARE 50 STATE LEGAL. SEE KNFILTERS.COM FOR CARB STATUS ON EACH PART FOR A SPECIFIC VEHICLE.