

**\*\*\*MAX. TONGUE WEIGHT - 4500 lb. (2043 kg)\*\*\*****C-667 SUBKIT****TOYOTA TUNDRA  
6.5 FT. STANDARD BED**

**WARNING!!** BRAKE, FUEL, AND ELECTRICAL LINES MAY NEED TO BE LOOSENED OR REPOSITIONED TO PROVIDE CLEARANCE FOR NEW HARDWARE. ALL MODELS REQUIRE MODIFICATION OR REMOVAL OF HEAT SHIELDS. ON SHORT BED MODELS, CHECK FOR ADEQUATE TURNING CLEARANCE BETWEEN THE FRONT OF ALL TRAILERS AND THE TRUCK CAB.

**INSTALLATION STEPS**

**WARNING!!** ON TWO WHEEL DRIVE TRUCKS A CLEARANCE CHECK MUST BE PERFORMED WHEN TRUCK IS LOADED AND UNLOADED TO VERIFY THE INVERTED BALL WILL NOT INTERFERE WITH THE TOP OF THE DIFFERENTIAL

**BEFORE INSTALLING**

- \*\*\*Brake lines MUST be cable tied as shown to prevent pinching of or cutting of brake lines when truck is loaded!\*\*\***
- \*\*\*An air bag suspension is recommended to be installed to prevent downward travel of bed and the cutting or pinching of brake lines, or damage to the rear axle when truck is loaded!\*\*\***
- \*\*\*Ball can not be turned over with this kit! Ball will interfere with rear axle if turned over and heavy load is applied!\*\*\***
- \*\*\*Curt Mfg. is NOT responsible for any damage to the brake lines or rear axle when these guidelines are ignored!\*\*\***

- 1) Mark the location for the hole in the truck bed. Measure from the tail gate end of the truck bed, by hooking a tape measure over the **back of the truck box** and marking the correct location. **(NOTE: DO NOT MEASURE FROM EDGE OF TAILGATE)** Next, mark the center between the wheel wells. This marks the center point for the 4" hole. This hole location is critical for the correct installation of this hitch. Measure, mark, and saw carefully. This location will put the ball 4"-6" in front of the axle.

**6.5' Standard Bed Installation      42 1/4"**

**NOTE:** If truck has a plastic bed liner, you may drill through both, but it is more difficult to accurately locate the midpoint between the wheel wells, and to keep the bed liner from moving while cutting the hole. Make a 4" hole at this location using a 4" hole saw, or by making a 4" circle and cutting it out with a saber saw equipped with a metal cutting blade.

- 2) For ease of installation, lower spare tire and remove rear most heat shield just above the exhaust pipe. Before installing the cross arms, remove the electrical wire harness by pulling the plastic clip loose from the passenger side frame rail and using pliers, bend the two weld nut tabs (between the two bed frame rails) straight down. This will allow the room needed between the bed frame rails to install this kit. Select the rear cross arm (only one set of notches) and from under the truck, lift the passenger side of the arm over the exhaust and on top of the frame. Push it above the frame as far in as possible and rotate the driver side of arm up on to the driver side frame rail. When the arm is spanning the frame, push it back against the bed frame rail. Repeat this process for the front cross arm (two sets of notches) keeping the second set of notches facing the front of the truck. Once the arm spans the frame, push it forward to the front bed frame rail.

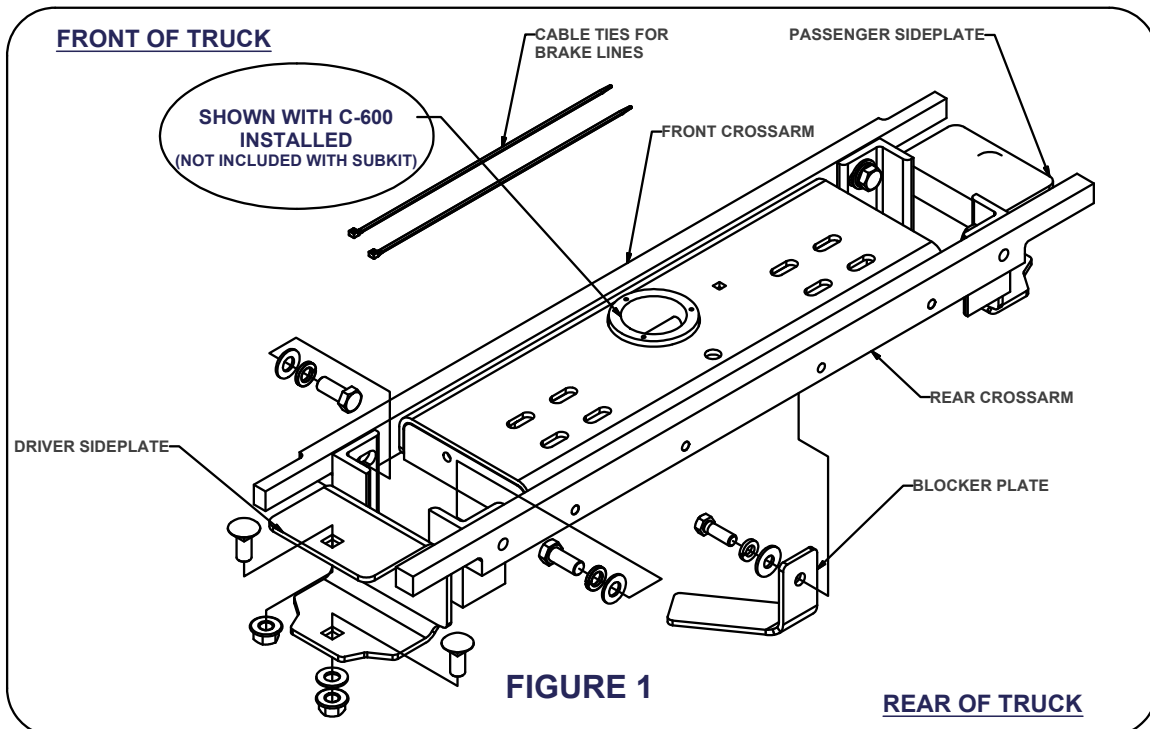
**FIGURE 1****REAR OF TRUCK**

Curt Manufacturing Inc., warrants this product to be free of defects in material or workmanship at the time of retail purchase by the original purchaser. If the product is found to be defective, Curt Manufacturing Inc., may repair or replace the product, at their option, when the product is returned, prepaid, with proof of purchase. Alteration to, misuse of, or improper installation of this product voids the warrant. Curt Manufacturing Inc.'s liability is limited to repair or replacement of products found to be defective, and specifically excludes liability for incidental or consequential loss or damage.

**\*\*DO NOT EXCEED RECOMMENDED VEHICLE TOWING WEIGHT!\*\***

## C-667 SUBKIT

TOYOTA TUNDRA  
6.5 FT. STANDARD BED

**\*\*\*MAX. TONGUE WEIGHT - 4500 lb. (2043 kg)\*\*\***

**WARNING!** BRAKE, FUEL, AND ELECTRICAL LINES MAY NEED TO BE LOOSENED OR REPOSITIONED TO PROVIDE CLEARANCE FOR NEW HARDWARE. ALL MODELS REQUIRE MODIFICATION OR REMOVAL OF HEAT SHIELDS. ON SHORT BED MODELS, CHECK FOR ADEQUATE TURNING CLEARANCE BETWEEN THE FRONT OF ALL TRAILERS AND THE TRUCK CAB.

### Installation Steps

- At this time, remove the rear most exhaust hanger bracket from the exhaust pipe. This will allow movement and more room to install the center section and sideplates. While under the truck at this time, disconnect the fuel pump control box on the driver side frame rail. This is necessary for installation of the sideplates.
- Raise the center section into position between the cross arms from beneath the truck. The round receiver tube that protrudes from the center section must face towards the front of the truck and fit through the hole in the truck bed floor. If you are using an overhead-lifting device, attach it to the receiver tube to help support the center section. Align the middle four threaded holes in the cross arms with the center section slots, and fasten the center section to the cross arms using (8) 1/2" x 1 1/2" bolts, with a flat washer and 1/2" lock washer on each. At this time, install the blocker plate to the inside flange of the center section as shown in the figure below. Use the overhead lifting device to put some upward pressure on the center section if necessary to aid alignment.
- Install the mounting plates at this time to the inside of the frame rails. First you must slide the angles up between the cross arms with the slotted holes toward the top. Then push them towards the frame of the truck. When properly fit, the two flanges of the sideplates will fit in between the C-channel of the frame. At this time, the loose exhaust is able to be pushed aside for ease of installation of the passenger sideplate. When the plates are in position, attach them to the crossarms using 5/8-11 x 1 1/2" hex bolts, 5/8" washers, and 5/8" lock washers as shown in the figure below. When finished, attach the plates to the frame using 5/8-11 x 1 1/2" carriage bolts and flange nuts as shown below. Make sure to install the carriage bolts correctly, or the handle to the center section will not install properly.
- With the sideplates installed on both sides, torque all 1/2" fasteners to 110 ft.-lbs and all 5/8" fasteners to 210 ft.-lbs. in the following order:  
**First:** Torque the sideplates to the frame.  
**Second:** Torque the sideplates to the cross arms.  
**Third:** Torque the center section to the cross arms.
- After everything is torqued, re-attach the exhaust to the exhaust hanger. Also, re-attach the fuel pump control box to the inside of the driver side frame just behind the driver sideplate, where it was removed earlier. Discard the heat shield and raise the spare tire back into position, if removed for ease of installation.

FRONT OF TRUCK  
CM-C600 CENTER SECTION

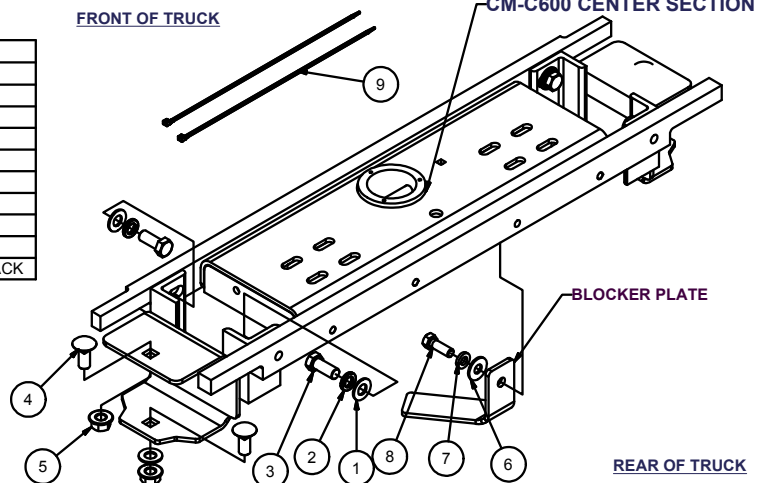

**(REFER TO GOOSENECK HITCH INSTRUCTIONS FOR INSTALLATION AND OPERATING PROCEDURES)**

### Maintenance (Required every 30 days or prior to use)

- Keep hitch ball lubricated regularly. Use silicone spray or equivalent to prevent wear and rust.
- Keep hitch assembly free of dirt and other foreign debris.
- Check for proper torque on all nuts and bolts before each use. Also check for excessive wear.
- Check for ball wear before each use. **(Note: Do not tow trailer with worn or damaged parts.)**

Curt Manufacturing Inc., warrants this product to be free of defects in material or workmanship at the time of retail purchase by the original purchaser. If the product is found to be defective, Curt Manufacturing Inc., may repair or replace the product, at their option, when the product is returned, prepaid, with proof of purchase. Alteration to, misuse of, or improper installation of this product voids the warrant. Curt Manufacturing Inc.'s liability is limited to repair or replacement of products found to be defective, and specifically excludes liability for incidental or consequential loss or damage.



**\*\*DO NOT EXCEED RECOMMENDED VEHICLE TOWING WEIGHT!\*\***

## C-667 SUBKIT

**TOYOTA TUNDRA  
6.5 FT. STANDARD BED**

**\*\*\*MAX. TONGUE WEIGHT - 4500 lb. (2043 kg)\*\*\***

**WARNING!!** BRAKE, FUEL, AND ELECTRICAL LINES MAY NEED TO BE LOOSENED OR REPOSITIONED TO PROVIDE CLEARANCE FOR NEW HARDWARE. ALL MODELS REQUIRE MODIFICATION OR REMOVAL OF HEAT SHIELDS. ON SHORT BED MODELS, CHECK FOR ADEQUATE TURNING CLEARANCE BETWEEN THE FRONT OF ALL TRAILERS AND THE TRUCK CAB.

### **\*\*BRAKE LINE ILLUSTRATIONS\*\***

**REAR AXLE, HITCH, AND BRAKE LINES**



**DISTANCE BETWEEN C-600 AND REAR AXLE**



**FACTORY DISTANCE BETWEEN BUMP STOPS**



**MODIFIED BRAKE LINES USING CABLE TIES**

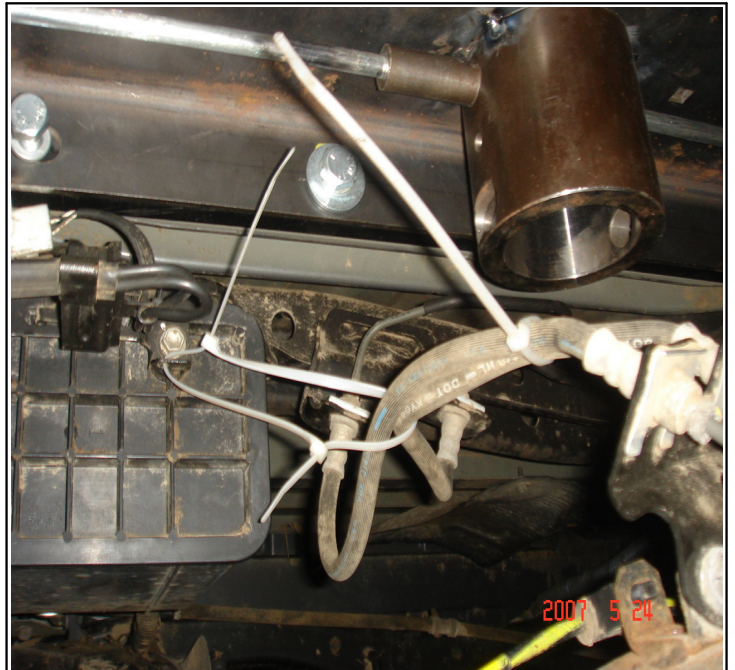

Curt Manufacturing Inc., warrants this product to be free of defects in material and/or workmanship at the time of retail purchase by the original purchaser. If the product is found to be defective, Curt Manufacturing Inc., may repair or replace the product, at their option, when the product is returned, prepaid, with proof of purchase. Alteration to, misuse of, or improper installation of this product voids the warranty. Curt Manufacturing Inc.'s liability is limited to repair or replacement of products found to be defective, and specifically excludes liability for incidental or consequential loss or damage.

**\*\*\*DO NOT EXCEED VEHICLE MANUFACTURER'S RECOMMENDED TOWING CAPACITY.\*\*\***

## CAB TO TRAILER CLEARANCE

**\*\*REMOVAL OF REAR WINDOW ACCESSORIES MAY BE REQUIRED.\*\***

### TRAILER

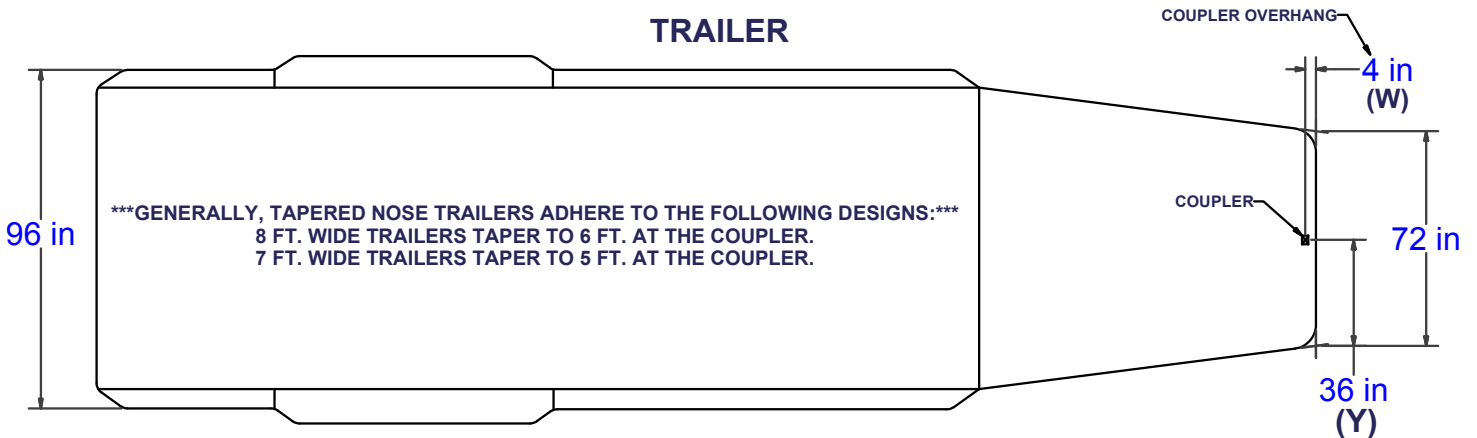

### LONG & SHORT TRUCK BEDS

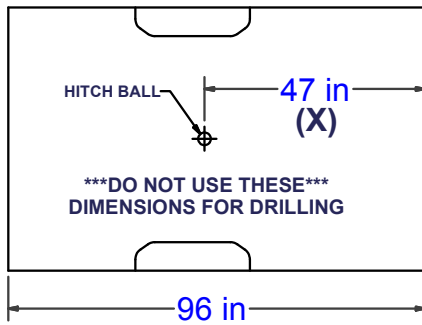

CAB OF TRUCK

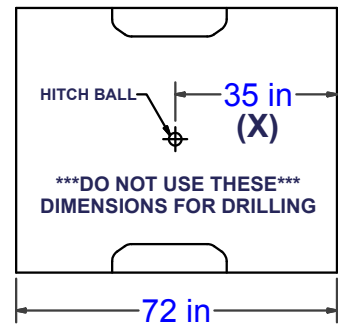

CAB OF TRUCK

### CLEARANCE CALCULATION

$$\text{(CAB TO BALL CENTER)} - \frac{1}{2} \text{(TRAILER WIDTH)} = \text{(MINIMUM CLEARANCE)}$$

$$(X) - (Y) = (Z)$$

IF THERE IS AN OVERHANG FROM THE COUPLER THEN THE EQUATION IS:

$$[(X) - (W)] - (Y) = (Z)$$

\*\*\*IF (Z) IS POSITIVE, TRAILER **WILL NOT** INTERFERE WITH CAB OF TRUCK.\*\*\*  
 IF (Z) IS NEGATIVE, TRAILER **WILL** INTERFERE WITH CAB OF TRUCK!!!

#### EXAMPLE:

##### STANDARD TRAILER

$$X - Y = Z$$

$$35 - 36 = -1$$

(TRAILER **WILL INTERFERE** WITH CAB)

##### TRAILER WITH OVERHANG

$$[(X) - (W)] - Y = Z$$

$$[35 - 4] - 36 = -5$$

(TRAILER **WILL INTERFERE** WITH CAB)

#### YOUR CALCULATION:

(CAB TO BALL CENTER) \_\_\_\_\_

(COUPLER OVERHANG) - \_\_\_\_\_

1/2 (TRAILER WIDTH) - \_\_\_\_\_

(MINIMUM CLEARANCE) = \_\_\_\_\_

Curt Manufacturing Inc., warrants this product to be free of defects in material or workmanship at the time of retail purchase by the original purchaser. If the product is found to be defective, Curt Manufacturing Inc., may repair or replace the product, at their option, when the product is returned, prepaid, with proof of purchase. Alteration to, misuse of, or improper installation of this product voids the warrant. Curt Manufacturing Inc.'s liability is limited to repair or replacement of products found to be defective, and specifically excludes liability for incidental or consequential loss or damage.