

60657

DODGE RAM 1500

12/26/2012

Page 1 of 7

WARNING!! BRAKE, FUEL, AND ELECTRICAL LINES MAY NEED TO BE LOOSENED OR REPOSITIONED TO PROVIDE CLEARANCE FOR NEW HARDWARE. ON SHORT BED MODELS, CHECK FOR ADEQUATE TURNING CLEARANCE BETWEEN THE FRONT OF ALL TRAILERS AND THE TRUCK CAB.

WARNING!! A CLEARANCE CHECK MUST BE PERFORMED ON TWO WHEEL DRIVE TRUCKS TO VERIFY THE INVERTED BALL WILL NOT INTERFERE WITH THE TOP OF THE DIFFERENTIAL WHEN LOADED.

***** HAVING INSTALLATION QUESTIONS? CALL TECHNICAL SUPPORT AT 1-800-798-0813 *****

Parts List			
ITEM	QTY	PART NUMBER	DESCRIPTION
1	2	5_8 FISHWIRE	5/8" FISHWIRE
2	2	1/2-13 x 2 1/4	HEX BOLT
3	10	1/2 - 13 x 1 1/2	HEX BOLT
4	10	1/2"	LOCK WASHER
5	12	FW12	FW, 12, ZP
6	12	HFN 1213	HEX FLANGE NUT
7	2	CM-1208-UBS	1/2-13 x 4 1/8 x 6 x 1 1/2 SQ U-BOLT
8	2	5/8-11 x 1 1/2	CARRIAGE BOLT
9	2	CM-SP9	.250 x 1.25 x 2.50" SQ. HOLE SPACER
10	2	5/8-11	HEX FLANGE NUT

TOOLS REQUIRED
FLAT SCREWDRIVER
3/4" AND 15/16" WRENCHES
3/4" AND 15/16" SOCKETS
RATCHET
TORQUE WRENCH
ADJUSTABLE WRENCH

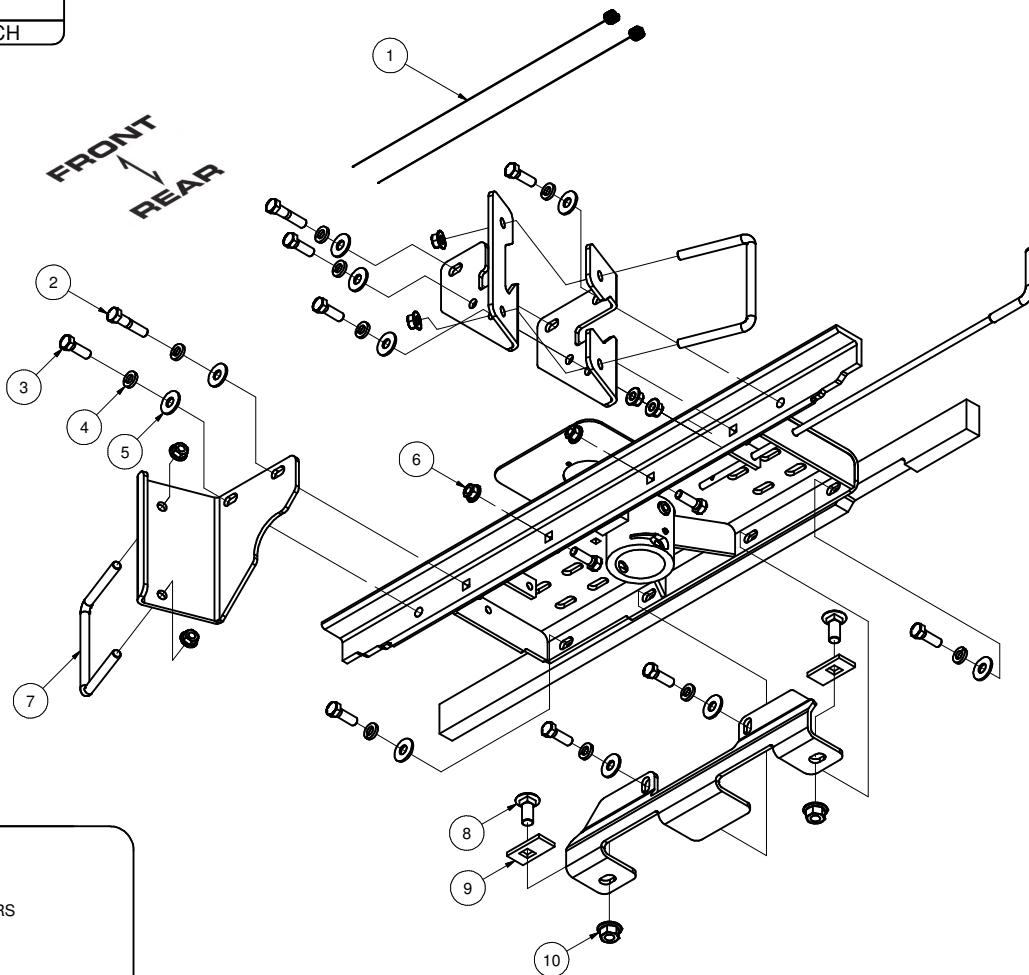
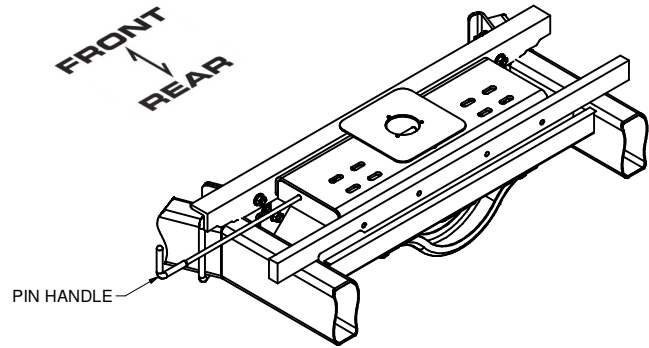

HITCH WEIGHT: 62 LBS.

INSTALL TIME

PROFESSIONAL: 2 HOURS

NOVICE (DIY): 5 HOURS

INSTALL NOTES:

- NO DRILLING REQUIRED

PERIODICALLY CHECK THIS RECEIVER HITCH TO ENSURE THAT ALL FASTENERS ARE TIGHT AND THAT ALL STRUCTURAL COMPONENTS ARE SOUND.

Curt Manufacturing Inc., warrants this product to be free of defects in material and/or workmanship at the time of retail purchase by the original purchaser. If the product is found to be defective, Curt Manufacturing Inc., may repair or replace the product, at their option, when the product is returned, prepaid, with proof of purchase. Alteration to, misuse of, or improper installation of this product voids the warranty. Curt Manufacturing Inc.'s liability is limited to repair or replacement of products found to be defective, and specifically excludes liability for incidental or consequential loss or damage.

60657

DODGE RAM 1500 (ALL)

12/26/2012

Page 2 of 7

INSTALLATION STEPS

BEFORE INSTALLING:

The use of a Curt C-606 Double Lock Gooseneck Install Tool is recommended to lift and hold the center section of the hitch in place during the installation. Maintaining upward pressure may facilitate fastening the cross-member to the center section, especially if the truck bed floor has been distorted downward from heavy use. If you use a C-606 Double Lock Gooseneck Install Tool, it should be disconnected before squaring the center section across the frame, installing the sideplates and torquing fasteners.

1. Mark Truck Bed for Hole Location:

Measure from the tailgate end of the truck bed, by hooking a tape measure over the **back of the truck box** and marking the correct location. (**NOTE: DO NOT MEASURE FROM THE EDGE OF THE TAILGATE.**) Next, mark the center between the wheel wells. This location should be in the center of a low rib in the bed floor. This hole is critical to the correct installation of the hitch. Measure, mark, and saw carefully.

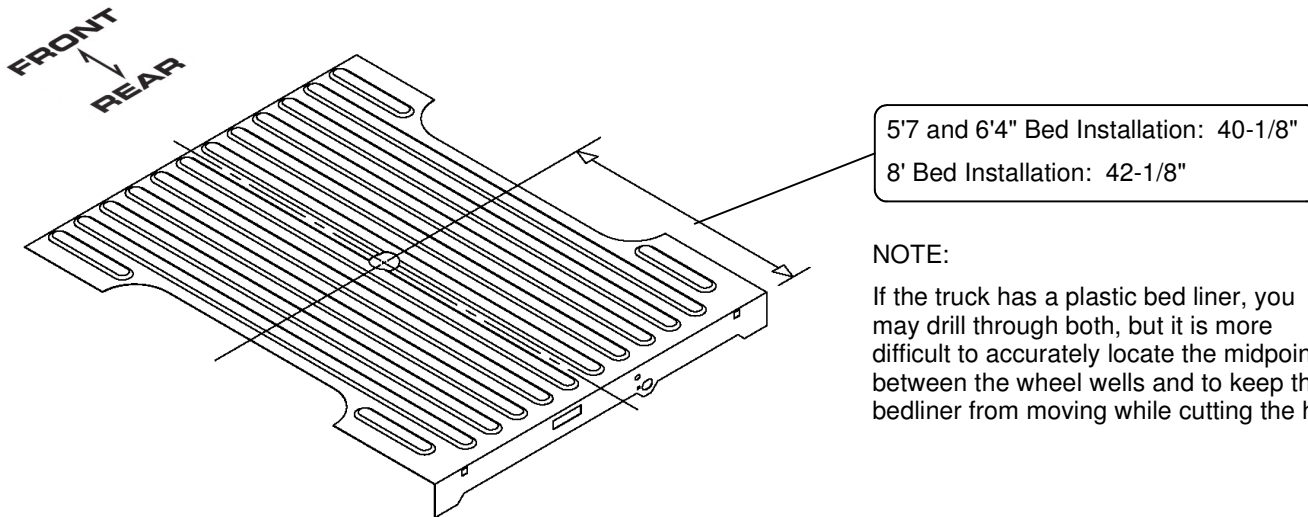

2. Cut Hole:

Make a 4" hole at the location marked in Step 1 using a 4" hole saw or by marking a 4" circle and cutting it out with a saber saw equipped with a metal cutting blade.

3. Install Rear Cross Member:

Before the hitch can be installed, a wiring harness and vent tube must be relocated. The wiring harness that must be relocated runs along the top of the frame cross member that is just behind the axle. The harness is secured to the top of the cross member by four plug fasteners. Pull each of the plug fasteners. Push the wiring harness toward the rear of the truck to make room for the rear cross member. The vent tube coming out of the rear axle is clipped to the same frame cross member. Remove the vent tube clip from the frame rail, allowing the vent tube to hang during the installation. (The vent tube will be relocated after the hitch is installed.)

PERIODICALLY CHECK THIS RECEIVER HITCH TO ENSURE THAT ALL FASTENERS ARE TIGHT AND THAT ALL STRUCTURAL COMPONENTS ARE SOUND.

INSTALLATION STEPS (con't.)

3. Install Rear Cross Member (con't.):

The rear cross member is the 2" x 1" bar with threaded holes. The cross member will be installed from the passenger side, just in front of the rear tire. (See Figure 3.1) Insert the cross member between the frame and the top suspension control arm with the notch machined into the cross member going first and facing the rear. Slide the leading end of the cross member above the exhaust and over the frame of the truck on the driver side while moving that end towards the rear. As the leading end gets to the driver side, raise the opposite end of the cross member up until both ends of the cross member can be positioned over the top of the frame with the cross member laying flat and the notch still facing the rear. (See Figure 3.2) Adjust the cross member so that it is parallel to the axle and slide it toward the rear of the truck until it is over the frame cross member where the wiring harness was attached. Rotate the cross member from flat to vertical so the notch on the driver side of the cross member is down. (See Figure 3.3) The notch provides clearance for the wiring harness and an exhaust bracket that is present on models that have dual exhaust. Slide the cross member rearward as far as possible while making sure the wiring harness does not get pinched or smashed. The cross member will rest on the frame and should be suspended just above the frame cross member.



CROSS MEMBER
Figure 3.1: As viewed from rear towards axle.



CROSS MEMBER
Figure 3.2: View under bed towards axle.

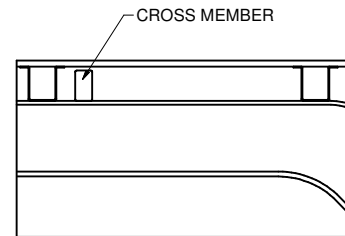

Figure 3.3: Cut-away under bed from passenger side of truck. (Just frame and box bed shown for clarity)

4. Install Center Section:

Position the center section so that the 4" diameter raised area of the center fits into the 4" hole in the truck bed. When installed, the round receiver will be almost directly above the axle of the vehicle. If the vehicle is equipped with dual exhaust, the installation is more difficult. From behind the rear axle and with the bottom side of the center section facing the passenger side of the truck, send the end of the center without the spring over the axle first. (See Figure 4.1) Send the lead end of the center toward the front of the truck and to the passenger side far enough so the end of the center toward the rear of the truck will clear the exhaust. (See Figure 4.2) Once the hitch is clear of the exhaust, rotate, and lift it so the 4" raised area is toward the bottom of the truck bed. Slide the center rearward over the exhaust until the 4" cylinder is in the 4" diameter hole in the truck bed. (See Figure 4.3)

If available, the C-606 Double Lock Gooseneck Install Tool can be attached to the latch pin of the center section at this time to apply upward pressure on the center, holding it in place.

Slide the rear cross member forward until it makes contact with the center section. Line the holes in the cross member up with the slots in the center. Attach the center to the rear cross member using the two outside slots in the center. Thread a 1/2" x 1-1/2" long bolt, a lock washer and a flat washer into each threaded hole in the rear cross member. Hand tighten the hardware at this time, do not fully tighten.



Figure 4.1: As viewed from rear towards axle.

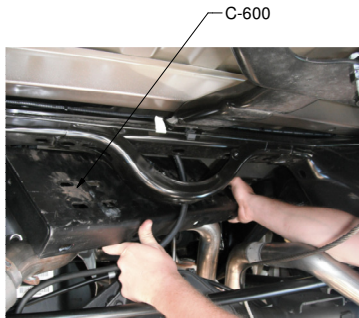

Figure 4.2: As view from rear towards axle.



Figure 4.3: As view from rear towards axle.

60657

DODGE RAM 1500 (ALL)

12/26/2012

Page 4 of 7

INSTALLATION STEPS (con't.)

5. Install Front Cross Member:

The front cross member is the 2 x 2-1/2" angle. Install the cross member from the passenger side in front of the rear tire. (See Figure 5.1 - 5.3) Position the cross member so it spans the frame and sits in an upside down "V" position with the holes toward the rear of the truck. Slide the cross member rearward to the center section. Center the cross member in the vehicle so that the holes in the cross member will line up with the slots in the center. Using an adjustable wrench or other means, stand the cross member up so the leg of the angle with holes is vertical. Slide the cross member back against the center. (See Figures 5.4)

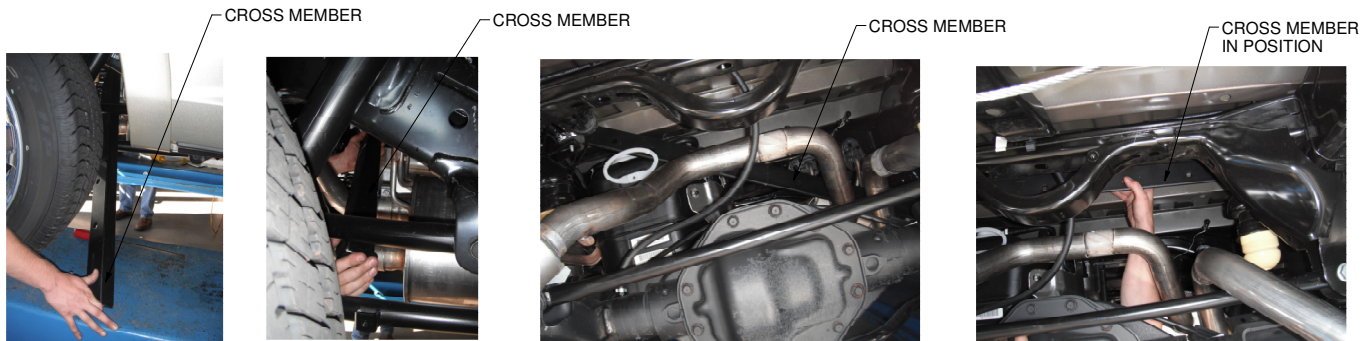

Figure 5.1: View from passenger side

Figure 5.2: View from passenger side

Figure 5.3: As viewed from rear towards axle.

Figure 5.4: As viewed from rear towards axle.

Attach the center and the cross member with two 1/2 x 2-1/4" bolts in the two center holes only. The bolt heads must be towards the rear of the truck. Add a flat washer, lock washer and hex nut to both bolts and hand tighten. Do not fully tighten at this time.

6. Install Side Plates:

Place one u-bolt in front of each coil spring around the truck frame as shown. (See Figure 6.1) To ease installation of the side plates, start with the u-bolts pulled back from the frame so the ends of the u-bolts are flush with the wall of the tubular frame.

Position the side plate with (2) bends so the two round holes match up with the u-bolt on the passenger side and push the u-bolt into the holes. (See Figure 6.2) Secure the side plate and u-bolt with lock washers and nuts. Attach this side plate to the front cross member and center using a 1/2" x 2-1/4" bolt through the center, cross member and side plate along with a lock washer, two flat washers and hex nut. Finish by attaching a 1/2" X 1-1/2" bolt through the cross member and the side plate adding a flat washer, lock washer and hex nut. Hand tighten these connections.

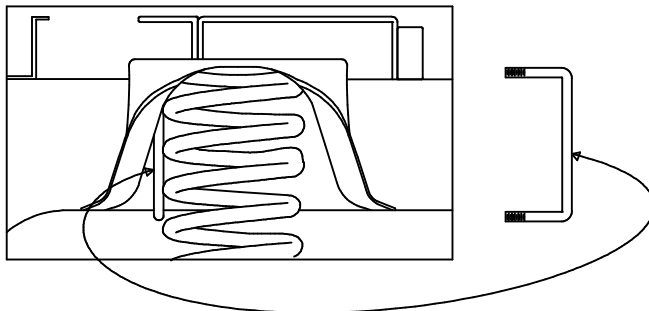

Figure 6.1: Driver side coil spring.
(Tire and wheel well liner not shown.)



Figure 6.2: Passenger side plate looking from floor up at the passenger side frame.

60657

DODGE RAM 1500 (ALL)

12/26/2012

Page 5 of 7

INSTALLATION STEPS (con't.)

6. Install Side Plate (con't.):

The two side plates that are left will be combined to secure the hitch on the driver side. Using the slot provided, maneuver the first side plate around the brake lines and line up the holes with the u-bolt. (See Figure 6.4) Insert the u-bolt into the holes on the side plate just enough to hold the side plate in place. Position the second side plate over the first as shown. (See Figure 6.5) Insert the u-bolt through the holes of the second side plate. Secure the side plates and u-bolt with lock washers and nuts. Fasten the two side plates together as shown using 1/2" x 1-1/2" bolts, lock washers and hex nuts. Attach these side plates to the front cross member and center using a 2-1/4" bolt through the center, cross member and side plate along with a lock washer, two flat washers, and a hex nut. Finish attaching the side plates by placing a 1/2" x 2-1/4" bolt through the cross member and the side plates adding a flat washer, lock washer and hex nut. Hand tighten these connections.



Figure 6.4: Driver side plate as viewed from floor up toward driver side frame. (Fuel tank is not shown.)



Figure 6.5: Driver side plate as viewed from floor up toward driver side frame. (Fuel tank is not shown.)

7. Install Rear Brace:

Use the fishwire tools provided to insert a 5/8-11 x 1" carriage bolt and CM-SP9 spacer into each of the cross member holes as shown using the slot that runs in the top of the coss member. (See Figure 7.2)

Install the rear brace by positioning the two large slots over the 5/8" carriage bolts. Attach the rear brace to the center section and the rear cross member with two 1/2-13 x 1-1/2 bolts, lock washer and flat washers. Hand tighten only at this time. Using the 5/8" flange nuts, secure the rear brace to the cross member. If the truck is equipped with dual exhaust, it may be helpful to pry the exhaust downward while installing the flange nut on the driver side bolt.



Figure 7.1: View under bed looking from floor to area above axle.

REAR BRACE

CARRIAGE BOLTS

REAR BRACE



Figure 7.2: View under bed looking from floor to area above axle.

8. Tighten Hardware:

Before tightening the hitch hardware, make sure the center section is tight against the bottom of the truck bed, and the hitch is centered and square in relation to the truck frame. Tighten the hitch hardware in the following sequence. Torque the 5/8" flange nuts to 210 ft. lbs. Be sure the rear cross member is centered across the frame and that the wiring harness is not pinched and then tighten the rear brace to the rear cross member and center. Tighten the center to the rear cross member. Be sure that the front cross member is centered and tighten the center to the cross member. Tighten both side plate u-bolts alternating between the top and bottom threads so the u-bolt is secured evenly. Torque the nuts on the u-bolts to 110 ft-lbs. Tighten the two bolts holding the side plates together on the driver side then tighten the side plates to the front cross member and center. Torque all 1/2" hardware to **110 ft. lbs.**

60657

DODGE RAM 1500 (ALL)

12/26/2012

Page 6 of 7

INSTALLATION STEPS (con't.)

8. Tighten Hardware (con't.)

Locate the axle vent tube that was disconnected from the frame at the beginning of the install. Relocate the vent by clipping the end to the frame cross member as shown. (See Figure 8.1)

9. Install Safety Chains:

To install safety chain u-bolts it is necessary to drill (4) 1/2" holes through the truck bed floor. Drill the holes so they match up with the two sets of holes on each side of the center. (See Figure 9.1) This may be done by drilling the 1/2" holes from the bottom using the center as a guide, or by drilling a small pilot hole from the bottom and drilling the 1/2" holes from the top side of the bed. Drop a u-bolt through each pair of holes from the top side of the bed floor. Place a spring and lock nut on each of the four legs. (See Figure 9.2) Tighten the lock nuts until they are flush with the bottom of the u-bolts.

10. Pin Handle Installation:

Remove the (11) screws securing the inner fender liner inside the driver side wheel well. To remove the liner, first remove the lower part of the liner up to the relief cut on the front and rear edges and then pull the liner down at the inside bottom edge to release the top edge from the lip of the wheel well.

Next measure from the rear screw hole 12" towards the front of the truck. Using a rotary cutting tool or grinder, remove a 3/4" wide x 1" tall slot as shown to allow the rod to be installed into the center section. (See Figure 10.1)

Trim the inner fender liner to match the slot cut in the wheel well. Reinstall the inner fender liner.

Install the pin handle in the vertical position as shown on Page 6. (Refer to center section installation instructions for complete details.)

11. Maintenance: (Required every 30 days or prior to use)

- A. Keep the hitch ball lubricated regularly. Use silicone spray or equivalent to prevent wear and rust.
- B. Keep hitch assembly free of dirt and other foreign debris.
- C. Check for proper torque on all nuts and bolts before each use. Also check for excessive wear.
- D. Check ball wear before each use.

(Note: Do not tow trailer with worn or damaged parts.)



Figure 8.1: Axle Vent Hose Relocation

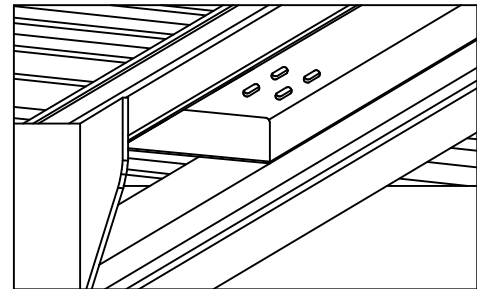

Figure 9.1: Safety Chain Bracket Hole Drilling

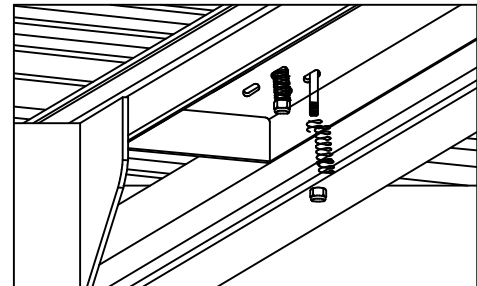

Figure 9.2: Spring Installation



Figure 10.1: Inside Driver Side Rear Wheel Well

60657

DODGE RAM 1500 (ALL)

12/26/2012

Page 7 of 7

TRAILER

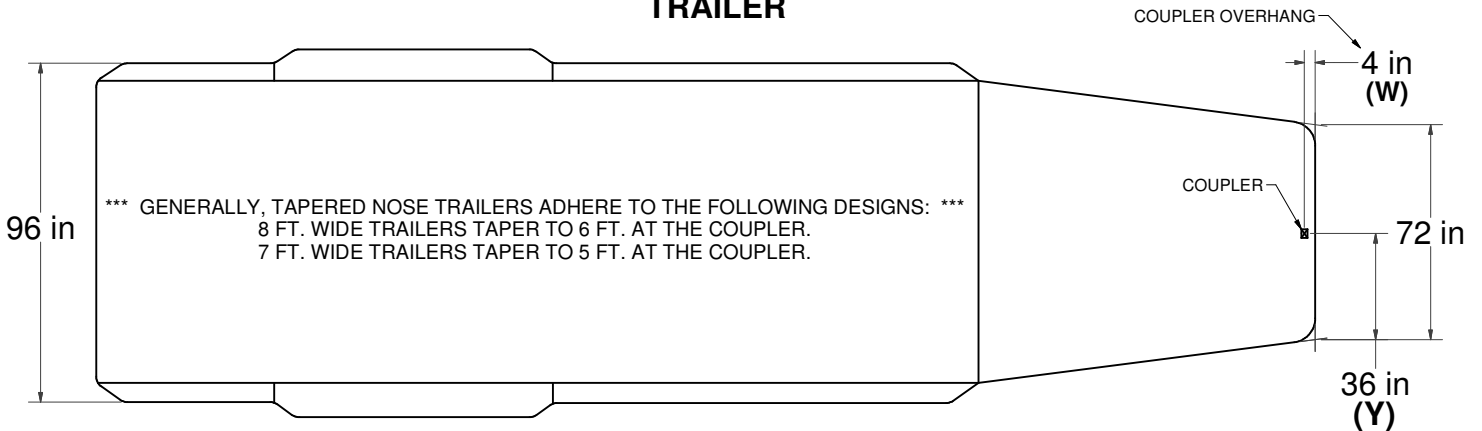

LONG & SHORT TRUCK BEDS

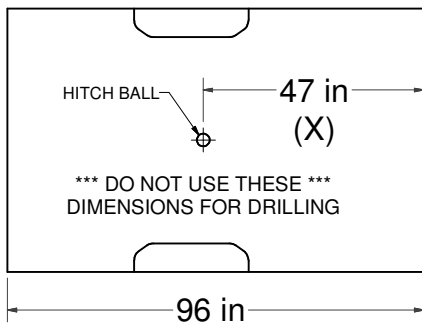

CAB OF TRUCK

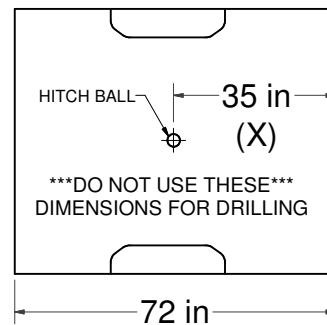

CAB OF TRUCK

CLEARANCE CALCULATION

$$\begin{matrix} \text{(CAB TO BALL CENTER)} & - & 1/2 \text{ (TRAILER WIDTH)} & = & \text{(MINIMUM CLEARANCE)} \\ \text{(X)} & - & \text{(Y)} & = & \text{(Z)} \end{matrix}$$

IF THERE IS AN OVERHANG FROM THE COUPLER THEN THE EQUATION IS:

$$\text{[(X) - (W)]} - \text{(Y)} = \text{(Z)}$$

IF (Z) IS POSITIVE, TRAILER **WILL NOT** INTERFERE WITH CAB OF TRUCK.
 IF (Z) IS NEGATIVE, TRAILER **WILL** INTERFERE WITH CAB OF TRUCK!!!

EXAMPLE:

STANDARD TRAILER

$$X - Y = Z$$

$$35 - 36 = -1$$

(TRAILER **WILL INTERFERE** WITH CAB)

TRAILER WITH OVERHANG

$$\text{[(X) - (W)]} - Y = Z$$

$$\text{[35 - 4]} - 36 = -5$$

(TRAILER **WILL INTERFERE** WITH CAB)

YOUR CALCULATION:

(CAB TO BALL CENTER) _____

(COUPLER OVERHANG) _____

1/2 (TRAILER WIDTH) _____

(MINIMUM CLEARANCE) _____