

16100 & 16200 MOUNTING RAIL INSTALLATION KIT

CUSTOM MOUNTING BRACKETS REQUIRED ON SOME INSTALLATIONS

DEALER/INSTALLER:

- 1) Provide this manual to end user.
- 2) Physically demonstrate procedure in this manual to end user.
- 3) Have end user demonstrate that he/she understands procedures.

END USER:

- 1) Read and follow this manual every time you use hitch.
- 2) Save this manual for future reference.
- 3) Pass on copies of manual to any other user or owner of hitch.

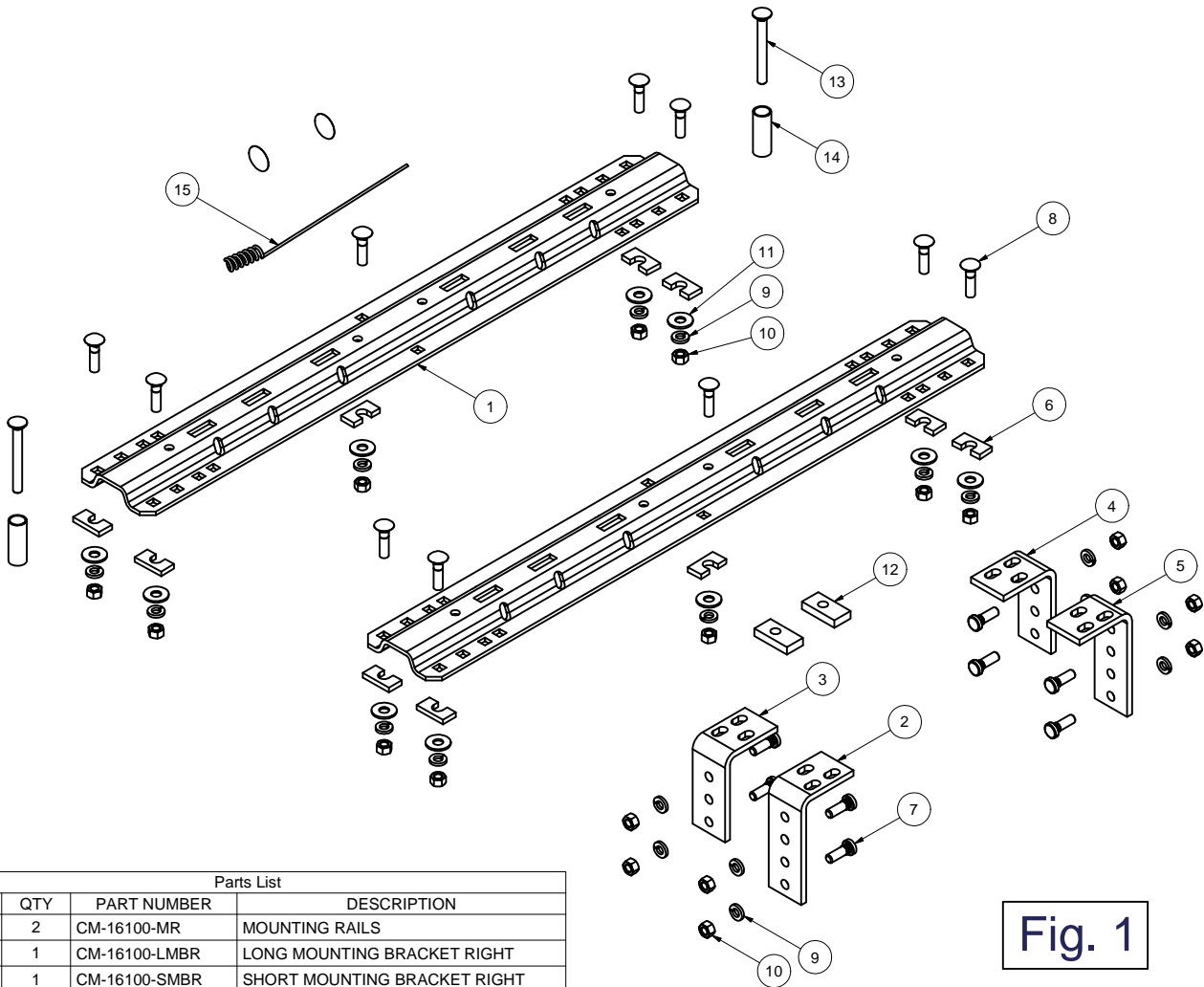

Fig. 1

Parts List			
ITEM	QTY	PART NUMBER	DESCRIPTION
1	2	CM-16100-MR	MOUNTING RAILS
2	1	CM-16100-LMBR	LONG MOUNTING BRACKET RIGHT
3	1	CM-16100-SMBR	SHORT MOUNTING BRACKET RIGHT
4	1	CM-16100-SMBL	SHORT MOUNTING BRACKET LEFT
5	1	CM-16100-LMBL	LONG MOUNTING BRACKET LEFT
6	10	CM-SP136	.313" x 1.00 x 2.00" U-SHAPE SPACER
7	8	1/2 - 13 x 1 1/2 WB	1/2 - 13 x 1 1/2 WHEEL BOLT
8	10	1/2 - 13 x 2"	CARRIAGE BOLT
9	18	1/2"	LOCK WASHER
10	18	1/2-13	HEX NUT
11	10	1/2"	WASHER
12	2	CM-SP52	.500 x 1.25 x 2.50" ROUND HOLE SPACER
13	2	1/2-13 x 4 1/2	CARRIAGE BOLT
14	2	CM-16100-TS	ROUND TUBE 1.00 OD x 14GA A-513
15	1	1/2"	FISHWIRE TOOL

CUSTOM MOUNTING BRACKETS REQUIRED ON SOME INSTALLATIONS

GENERAL INSTRUCTIONS FOR MOUNTING RAIL INSTALLATION

TOOLS

3/16" drill	3/4" Socket & Open End Wrench
17/32" drill	100 lb-ft Torque Wrench
1" drill (Some Dodge application only)	"C" Clamps

1. The following instructions should be used to mount the 5th wheel. Care and attention to detail will ensure a quality installation. Check parts against parts list to become familiar with parts in kit. (See Fig. 1)
2. Raise rear of truck high enough to allow jack stands to be placed under rear spring hanger bracket of truck. This will provide maximum room to install the 5th wheel brackets.



WARNING:

If the truck is raised, be sure that the truck is properly blocked and restrained to prevent the truck from falling. Failure to do so may result in the truck suddenly falling, causing death or serious injury.

3. Do not install mounting rails over plastic bed liners. Plastic bed liners must be cut out of the way. Mounting rails may be installed on spray in liner. **Note:** Consult installer for recommended curing time.
4. Use only the supplied bolts, nuts, and washers to install this kit. All installation hardware is grade 5 unless otherwise specified.
5. Specific instructions for most commonly used vehicles are included. If these instructions do not apply to your vehicle, be sure that each end of each base rail is connected to the vehicle frame. Each frame bracket must be bolted to the vehicle frame with two bolts, unless optional weld is used.



CAUTION:



These instructions are guidelines only. Actual installation is the responsibility of the installer and the owner. Always measure truck and trailer before installing hitch to be sure that there is clearance at the cab and at the bumper to allow for turns.

To prevent the trailer from hitting the cab with the trailer turned 90°, the center of the hitch should be at least 52" from the back of the cab when using a long bed truck. (Actual distance required will depend on trailer width and king pin location.) Short bed (Minimum 38" from back cab to axle center line) trucks require a minimum of a 13" extended pin box for regular maneuvers and do not apply.

6. Measurements are given from Rear Edge of truck bed to rear edge of the mounting rail closest to the Rear Edge of truck for most vehicle applications (See Fig. 2).
7. **Center hitch between fender wells and make sure rails are square. Adjust position of rails until both diagonal measurements are the same. This should allow installation of a gooseneck or other 5th wheels to these rails (See Fig. 2).**



CAUTION:



Check for obstructions before drilling. Failure to do so could result in damaged fuel or brake lines, structural members, etc. CURT MANUFACTURING does its best to communicate tow vehicle manufacturer changes; however, it is ultimately the responsibility of the installer to prevent damage due to installation.

8. Drill 10 holes identified in Fig. 2. (Hole location will vary for individual vehicle applications.) Drill all holes with 3/16" drill and enlarge them with a 17/32" drill. Always use sharp drill bits. A 3/16" pilot hole will greatly speed drilling larger holes. Install 1/2" carriage bolts into holes. Install 5/16" thick slotted spacer above or below bed to fill corrugations in bed floor. **NOTE: For Toyota Tundra application, part #16302 spacer kit is required. Stack (1) 3/16" and (1) 5/16" thick slotted spacer to avoid crushing of truck bed.**

9. Install mounting brackets onto carriage bolts with the long brackets on forward bolts and short brackets on rearward (long and short brackets can be interchanged as needed). Secure bolts through mounting brackets with serrated washers, lock washers, and hex nuts. Secure the other four bolts through the bed with flat washers, lock washers, and nuts.

For Installation Assistance or Technical Help, Call 1-800-798-0813

10. Drill two holes in frame for each bracket. Select the holes which will give the greatest spread between bolts. Install eight 1/2"-13x1-3/8" ribbed neck bolts, (thread pointing out), lock washers, and hex nuts. Tighten nuts until bolt heads seat. Lubrication of knurls of all rib neck bolts is recommended.

Note: On vehicles with heavy duty suspensions, check for interference with bolts where brackets are mounted to frame. If interference with suspension spring results, cut bolt flush to nut outboard of frame or use weld option.

 **WARNING:**
DO NOT lubricate threads. It may cause bolt failure.

 **CAUTION:** 
Check for obstructions before drilling. Failure to do so could result in damaged fuel or brake lines, structural members, etc. CURT MANUFACTURING does its best to communicate tow vehicle manufacturer changes; however, it is ultimately the responsibility of the installer to prevent damage due to installation.

 **CAUTION:** 
It is important that 17/32" drill be used for holes in chassis frame as rib neck bolts may break if too small a hole is used and neck may not grip if too large a hole is used.

11. Torque all nuts to 85 lb-ft

12. Pull wire provided to pull rib neck bolts through frame as needed per application

Drill locations will vary. See individual installation for location

Use mounting channel/cross member assembly to position rails (not included).

**** Diagonal Measurements must be the same for smooth Operation of 16500 rolling units ****

Fig. 2

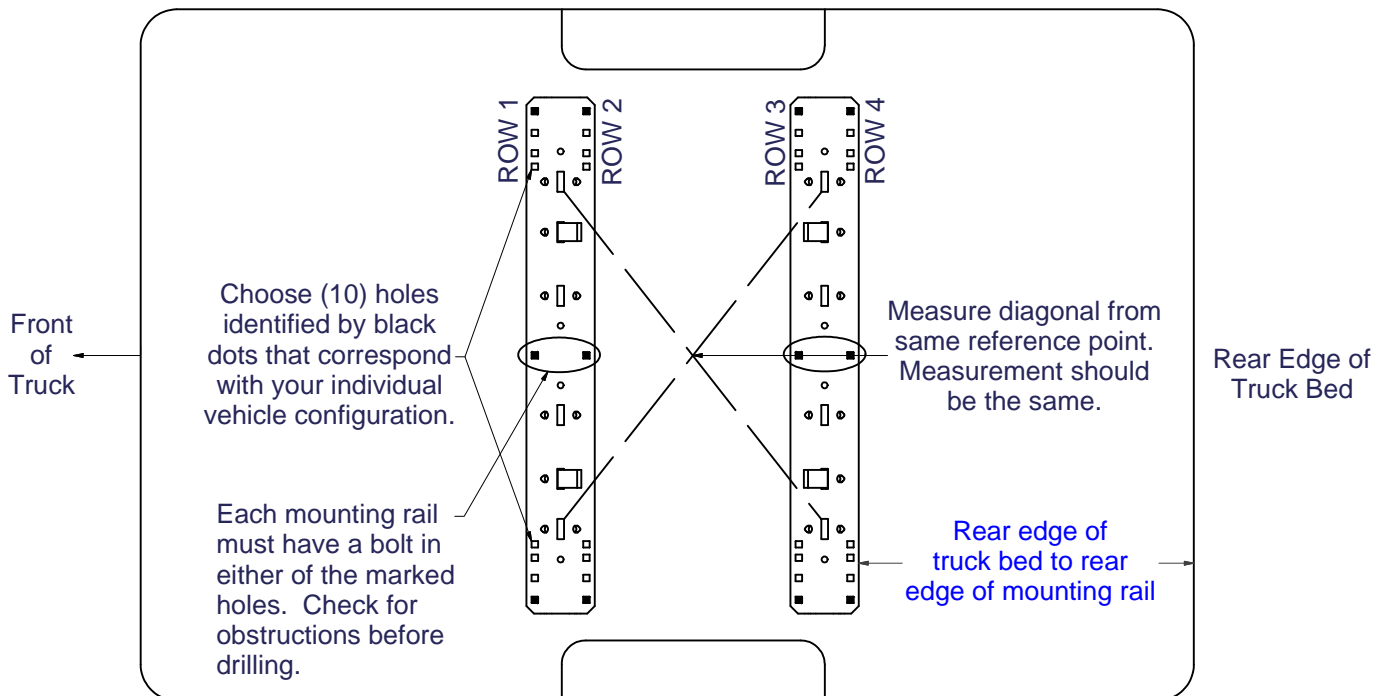

**CHEVROLET/GMC 88-98, 92-98 4-DOOR, '99 SILVERADO
SIERRA CLASSIC (WITH TAPERED FRAME) (RED TURN SIGNALS)**



Read pages 2-3 of these instructions before starting installation. Failure to do so could result in significant vehicle damage!

IMPORTANT NOTES FOR THIS INSTALLATION:

1. Find parallel rows of bed sill spot welds in bed of truck. No drilling should be done in the ~4" between parallel rows of spot welds where the bed sill sits.

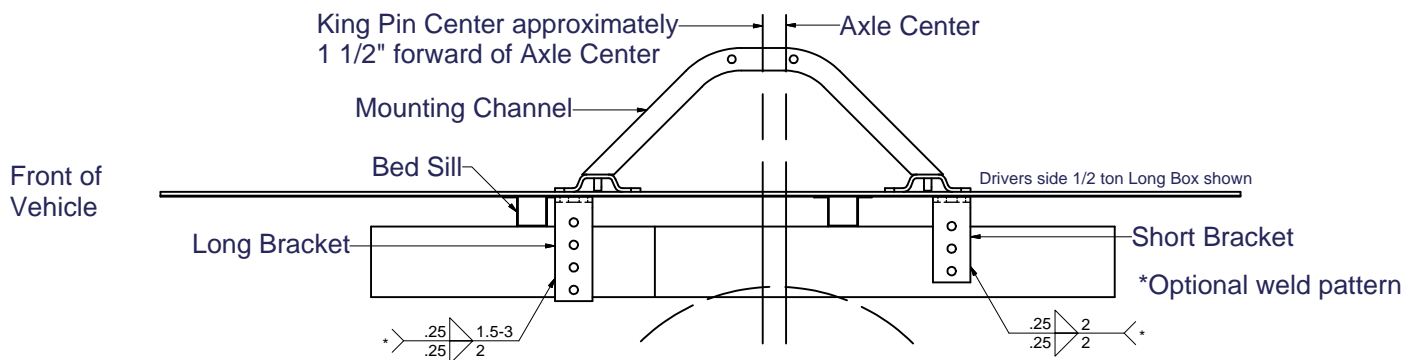
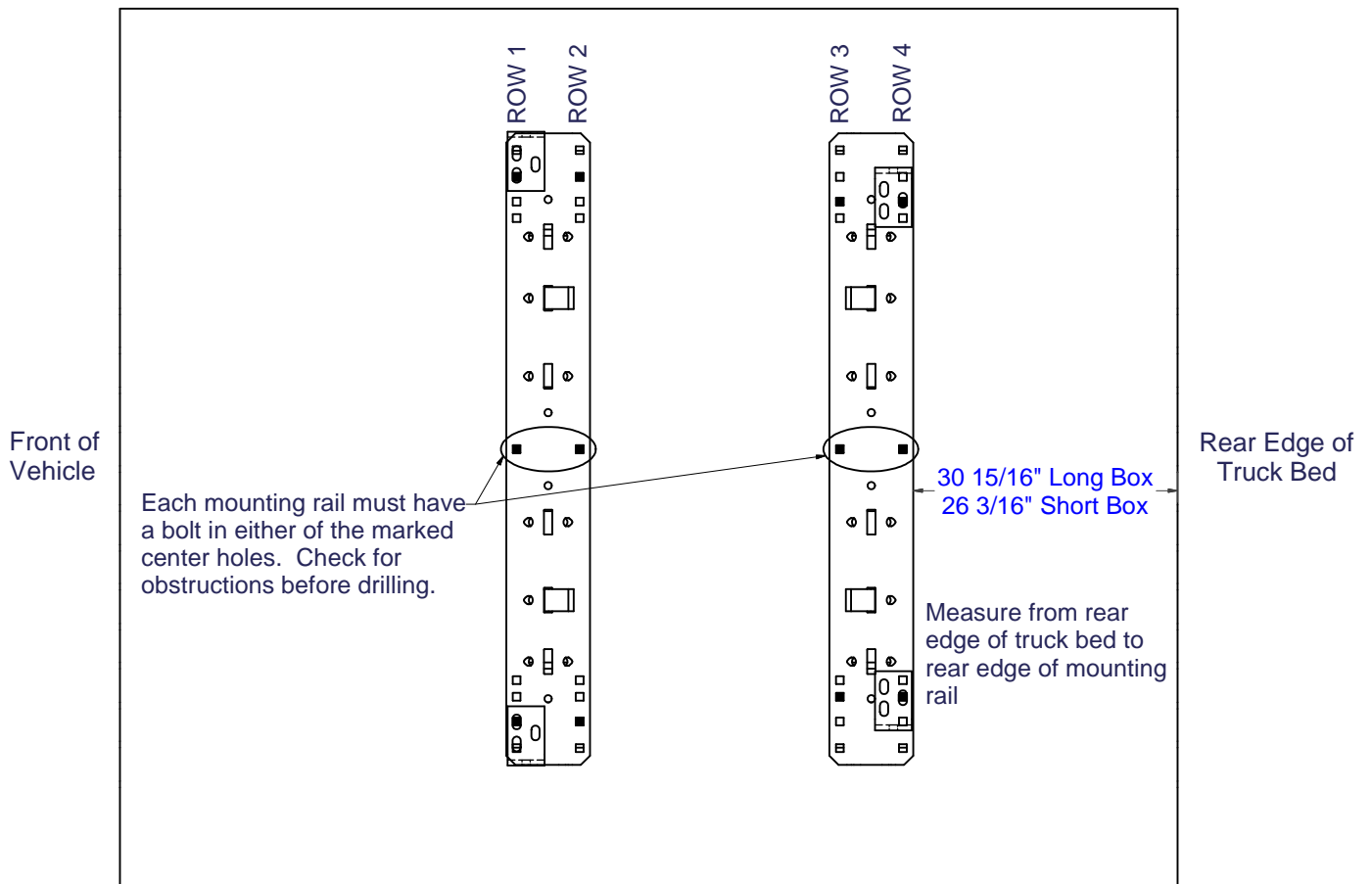

Check for obstructions before drilling. Failure to do so could result in damaged fuel or brake lines, structural members, etc. CURT MANUFACTURING does its best to communicate tow vehicle manufacturer changes; however, it is ultimately the responsibility of the installer to prevent damage due to installation.

**GM '99 Silverado, Sierra (not Sierra Classic) models, GM '00 to '10 Silverado,
Sierra models including HD models**



Read pages 2-3 of these instructions before starting installation. Failure to do so could result in significant vehicle damage!

IMPORTANT NOTES FOR THIS INSTALLATION:

1. Find parallel rows of bed sill spot welds in bed of truck. No drilling should be done in the ~4" between parallel rows of spot welds where the bed sill sits.

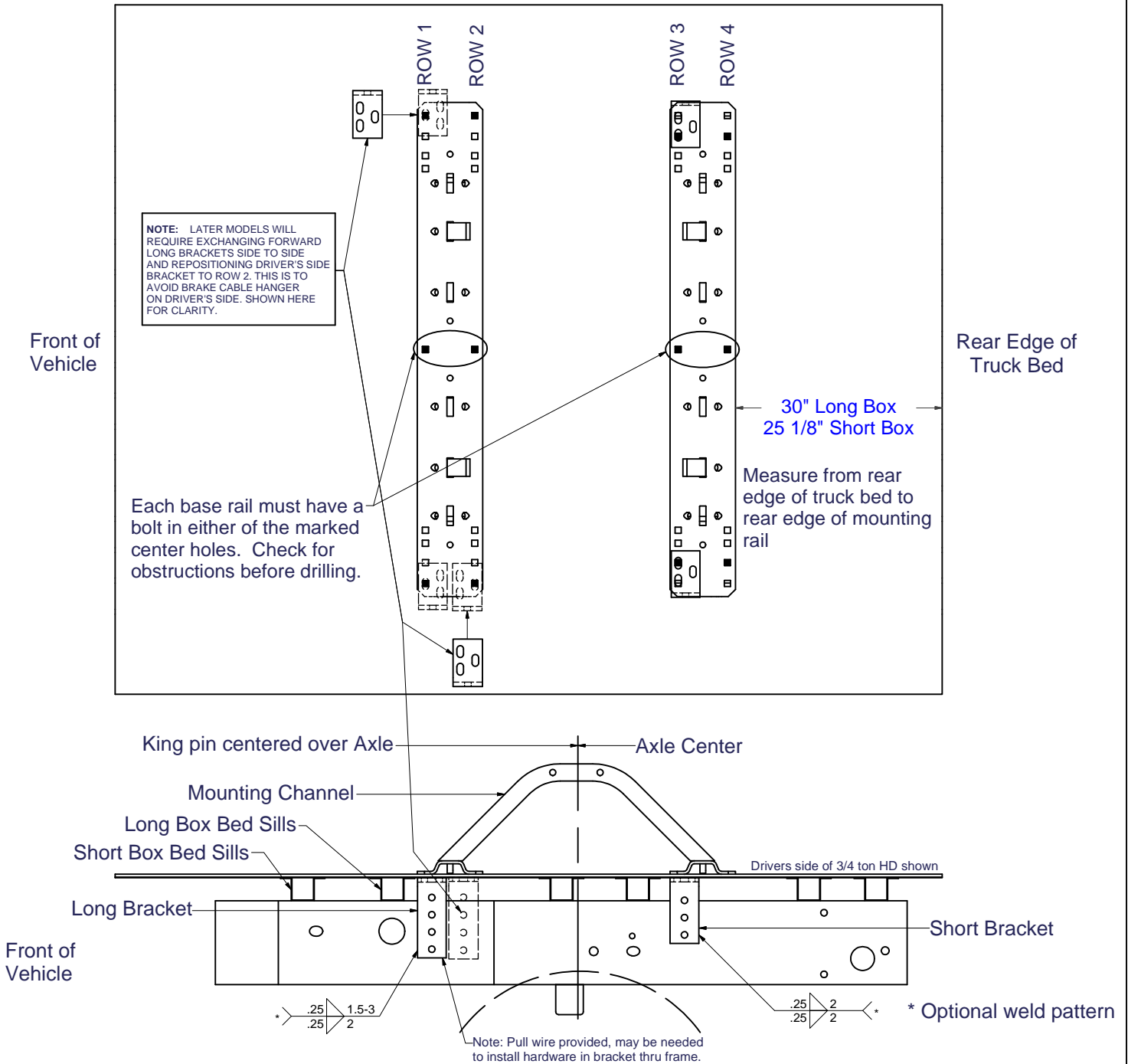

Check for obstructions before drilling. Failure to do so could result in damaged fuel or brake lines, structural members, etc. CURT MANUFACTURING does its best to communicate tow vehicle manufacturer changes; however, it is ultimately the responsibility of the installer to prevent damage due to installation.

GM '11 SILVERADO



Read pages 2-3 of these instructions before starting installation. Failure to do so could result in significant vehicle damage!

IMPORTANT NOTES FOR THIS INSTALLATION:

1. Find parallel rows of bed sill spot welds in bed of truck. No drilling should be done in the ~4" between parallel rows of spot welds where the bed sill sits.

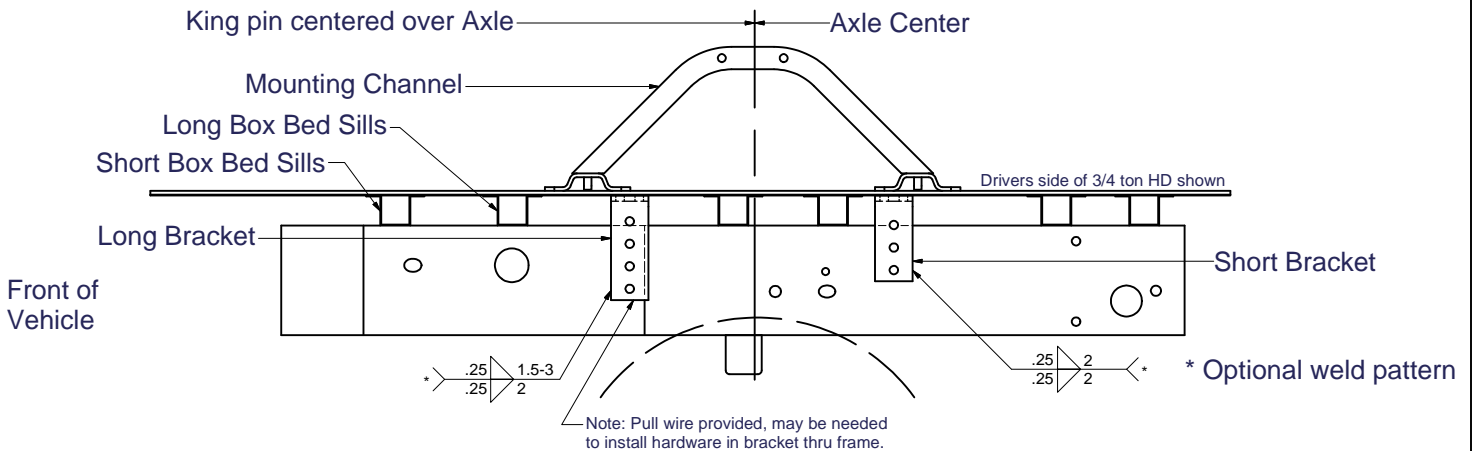
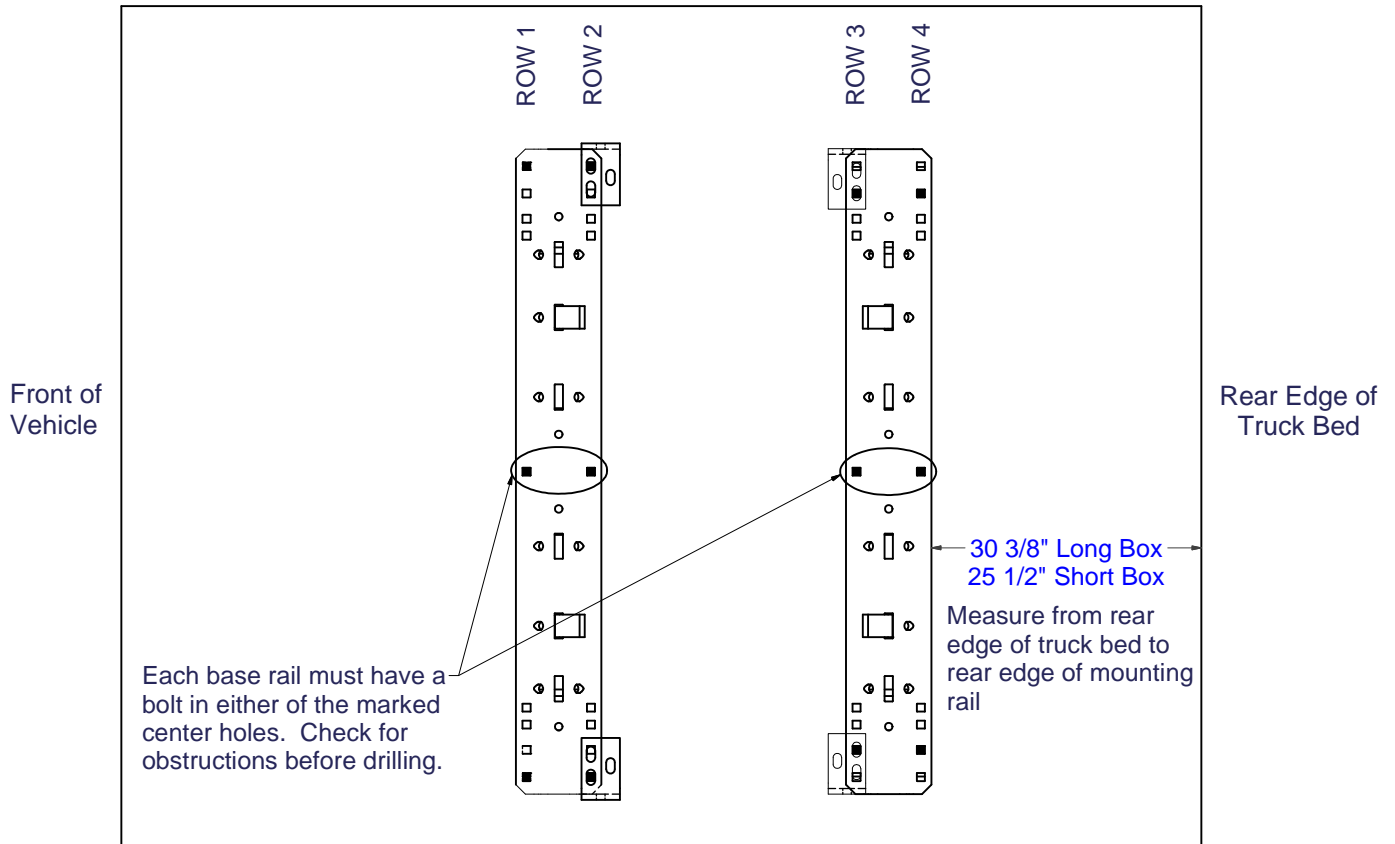

Check for obstructions before drilling. Failure to do so could result in damaged fuel or brake lines, structural members, etc. CURT MANUFACTURING does its best to communicate tow vehicle manufacturer changes; however, it is ultimately the responsibility of the installer to prevent damage due to installation.

Chevrolet 73 to 87, 73 to 92 4-door (GMC) (34' Straight, with Outside Shock Absorbers)



Read pages 2-3 of these instructions before starting installation. Failure to do so could result in significant vehicle damage!

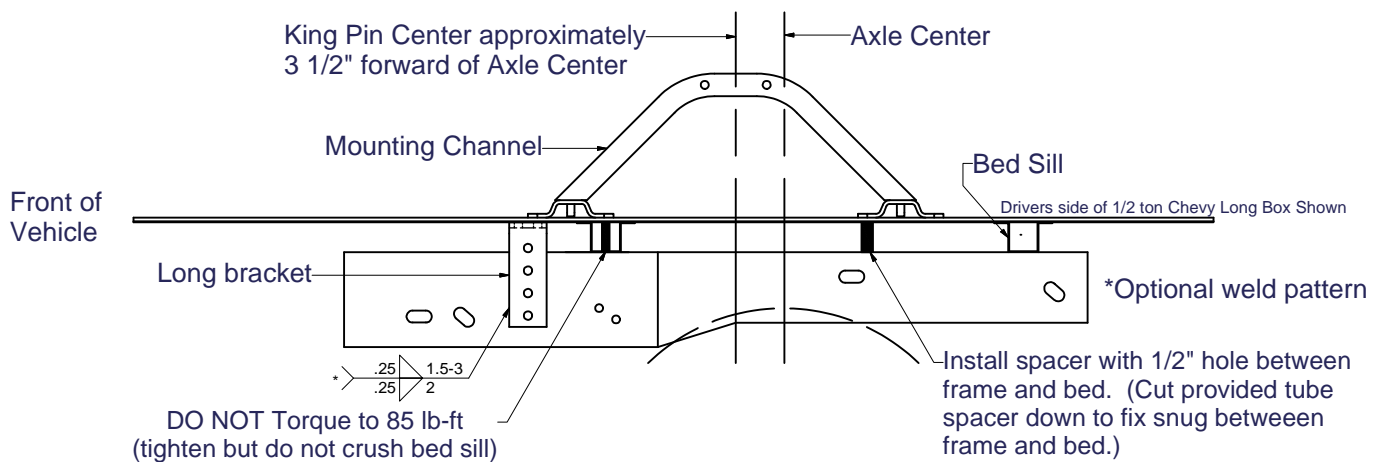
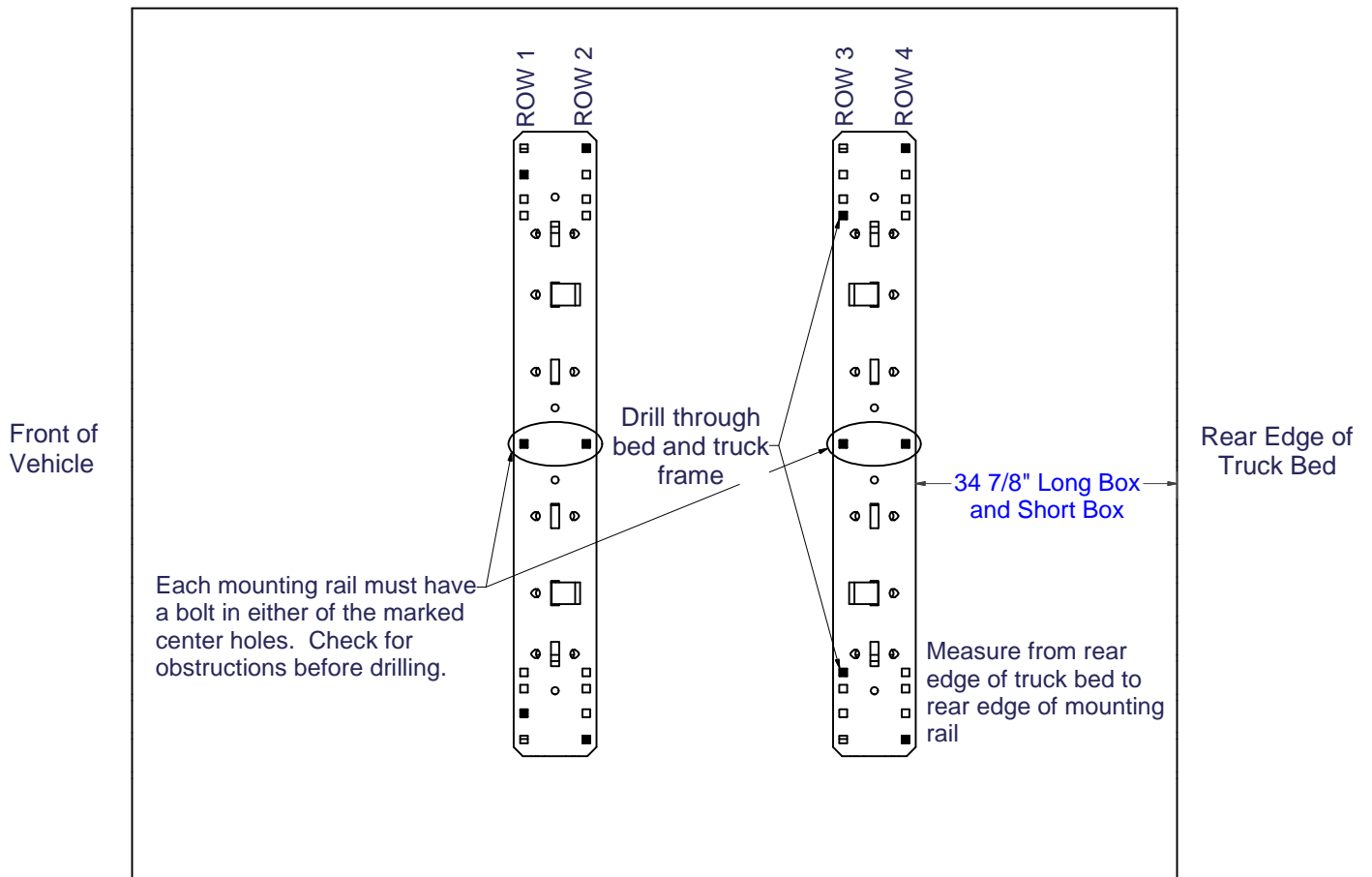

Check for obstructions before drilling. Failure to do so could result in damaged fuel or brake lines, structural members, etc. CURT MANUFACTURING does its best to communicate tow vehicle manufacturer changes; however, it is ultimately the responsibility of the installer to prevent damage due to installation.

Chevrolet 73 to 87, 73 to 92 4-door (GMC) (34' Straight, with Inside Shock Absorbers)



Read pages 2-3 of these instructions before starting installation. Failure to do so could result in significant vehicle damage!

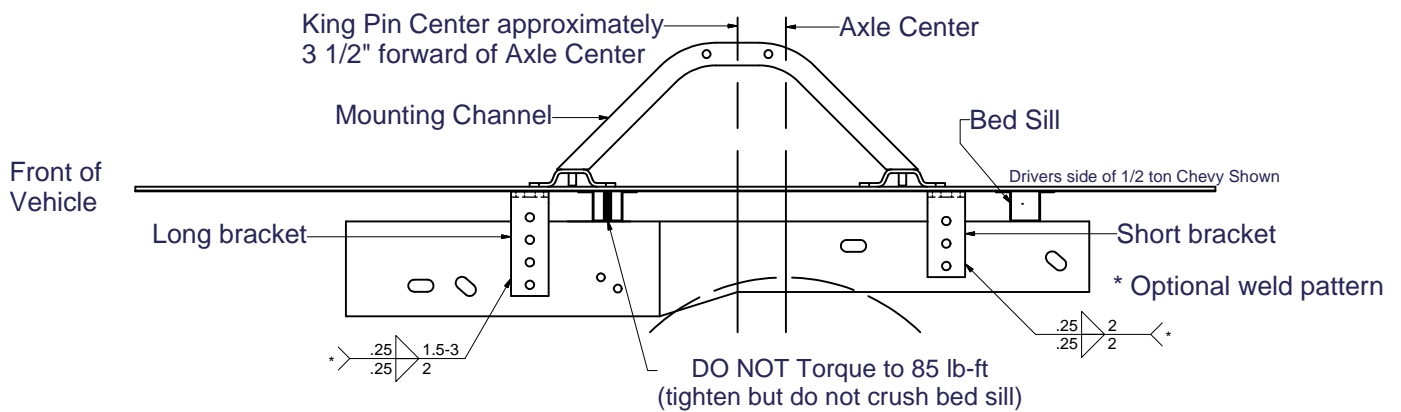
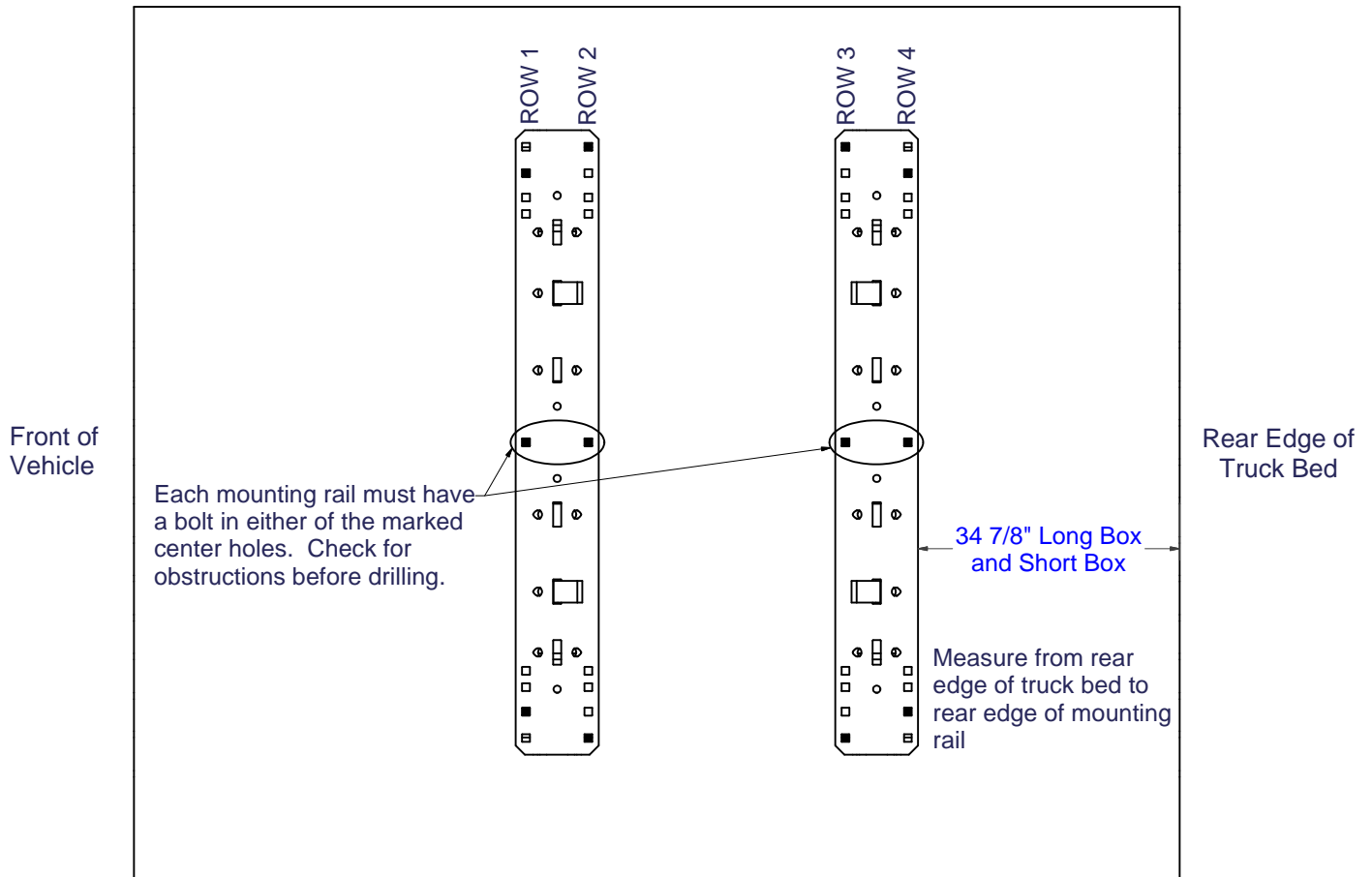

Check for obstructions before drilling. Failure to do so could result in damaged fuel or brake lines, structural members, etc. CURT MANUFACTURING does its best to communicate tow vehicle manufacturer changes; however, it is ultimately the responsibility of the installer to prevent damage due to installation.

Ford '97 to '03 F-150 & F-250 8500 GVW AND UNDER and '04 Heritage Series Body Style



Read pages 2-3 of these instructions before starting installation. Failure to do so could result in significant vehicle damage!

IMPORTANT NOTES FOR THIS INSTALLATION:

1. Long and Short Brackets on Driver's Side may need to be switched to avoid interference with exhaust hanger.
2. You may need to move mounting rail location +/- 1/2" to ensure frame brackets do not interfere with bed sills.

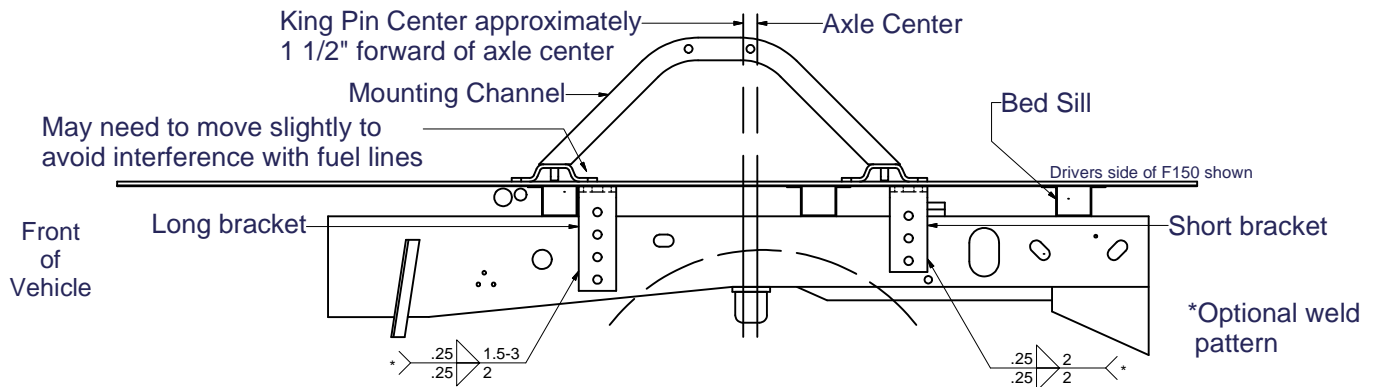
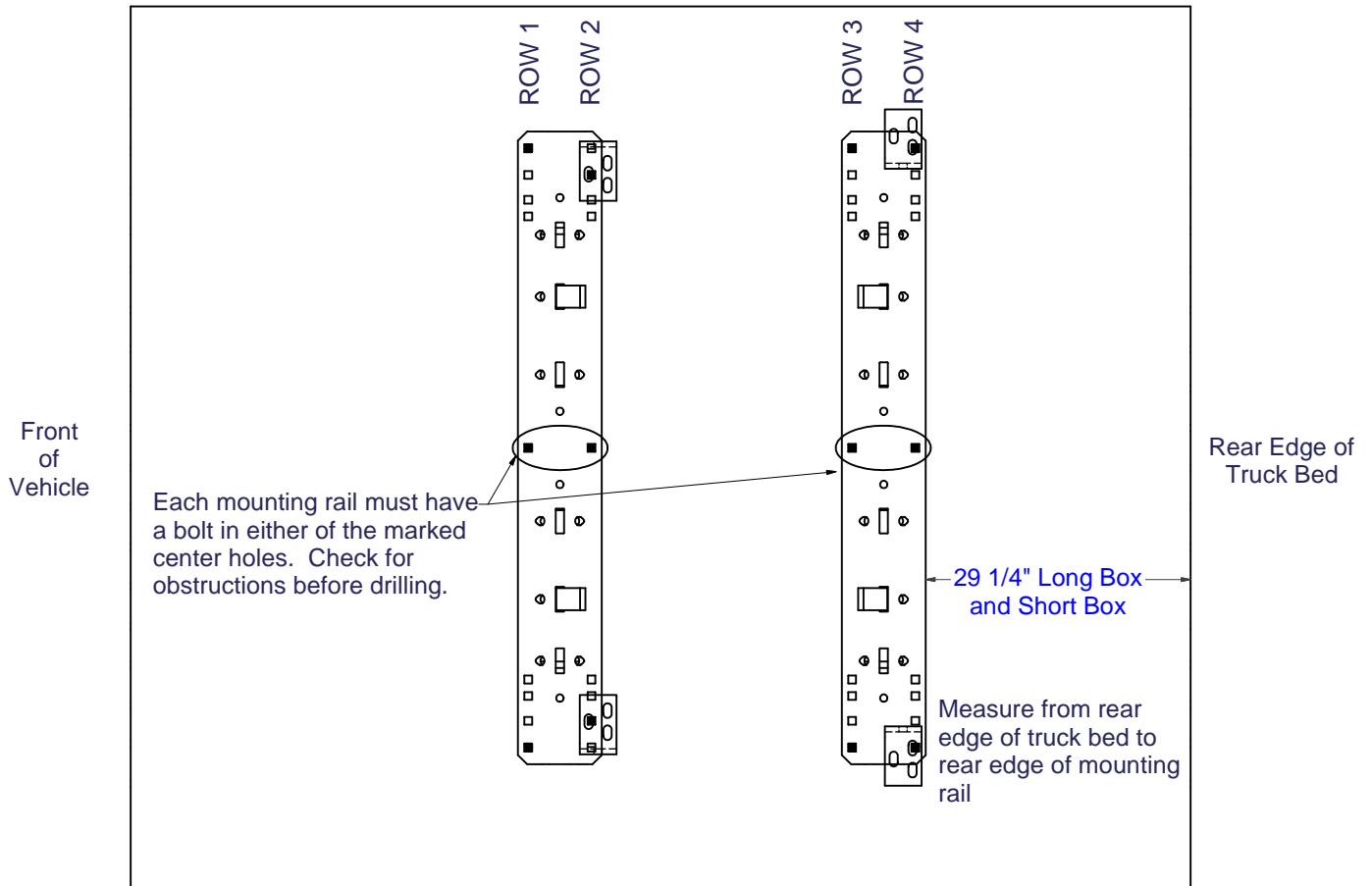

Check for obstructions before drilling. Failure to do so could result in damaged fuel or brake lines, structural members, etc. CURT MANUFACTURING does its best to communicate tow vehicle manufacturer changes; however, it is ultimately the responsibility of the installer to prevent damage due to installation.



Read pages 2-3 of these instructions before starting installation. Failure to do so could result in significant vehicle damage!

IMPORTANT NOTES FOR THIS INSTALLATION:

1. Do not drill through both walls of frame. Drill only through wall of frame to which bracket is mounted.
2. Find parallel rows of bed sill spot welds in bed of truck. No drilling should be done in the ~4" between parallel rows of spot welds where the bed sill sits.

3. Remove jounce block from Bottom of frame on both sides.

4. When brackets are in place one of the front 2 holes should line up with a hole in the frame. A hole will need to be drilled in the frame at the rearward bracket hole.

5. Pull carriage bolts with bolt plates (using supplied pull wire) through the hole in the bottom of frame (where the jounce block was removed) and through the rear hole in each bracket. On the forward brackets a carriage bolt, spacer, and a 1" washer should be pulled through the forward hole. On the rearward brackets a carriage bolt, spacer, and 13/16" washer.

6. Replace the jounce block.

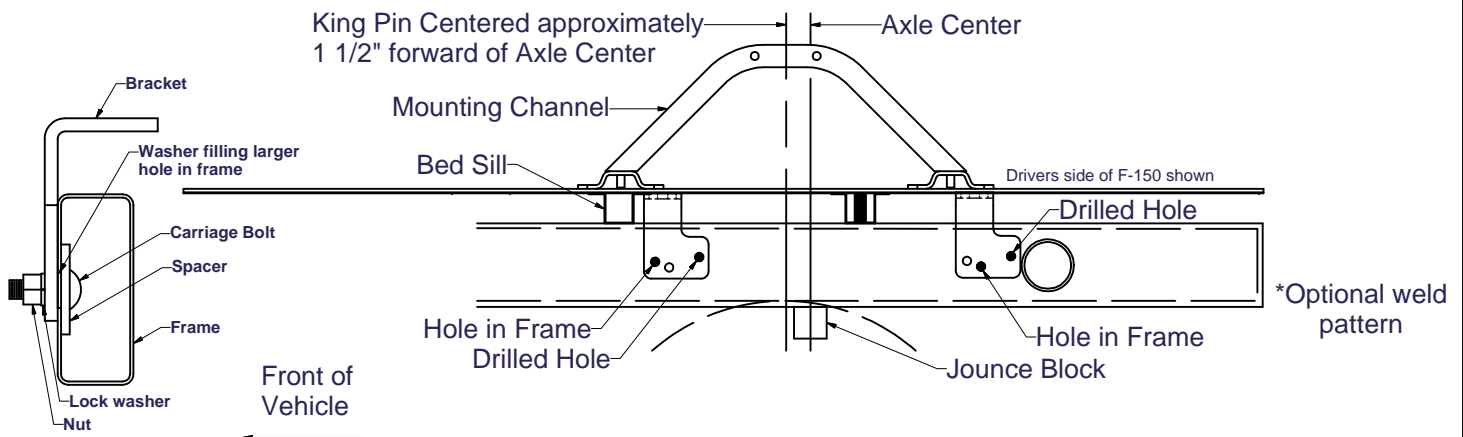
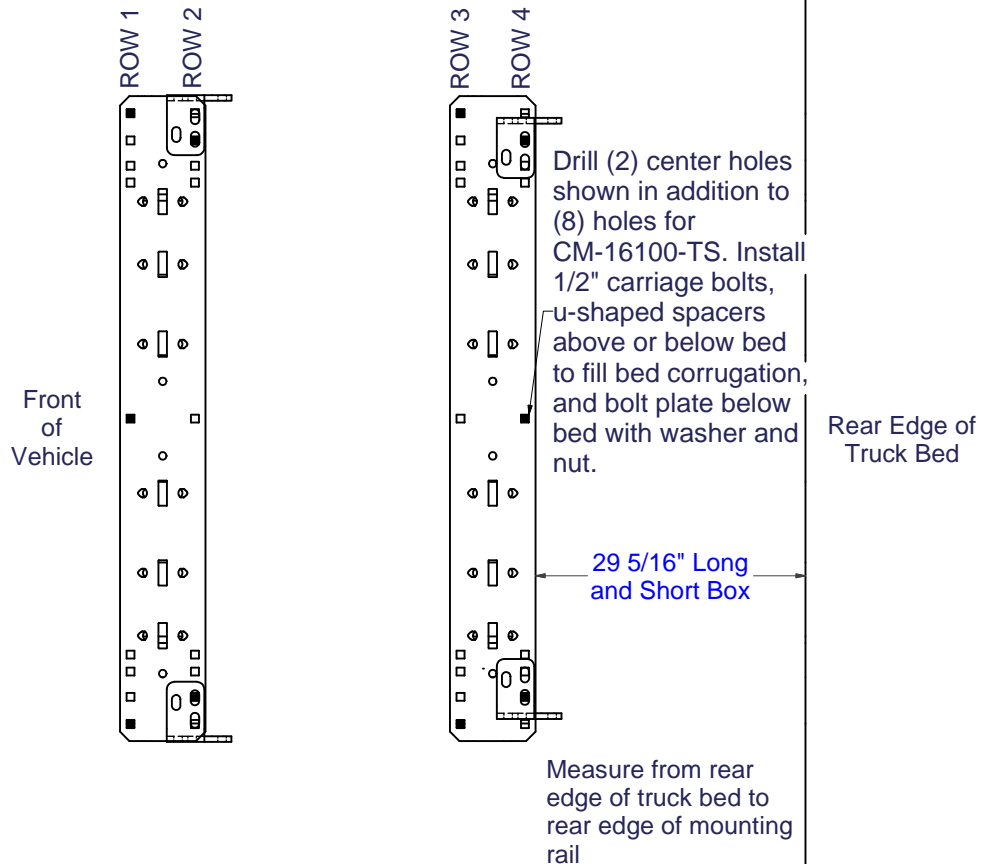

Check for obstructions before drilling. Failure to do so could result in damaged fuel or brake lines, structural members, etc. CURT MANUFACTURING does its best to communicate tow vehicle manufacturer changes; however, it is ultimately the responsibility of the installer to prevent damage due to installation.

**FORD F-150 & F-250 THROUGH '96, '97 F-250 OVER 8500 GVW, F350 THROUGH '97
1999 & NEWER F-250 / F-350 & f-450 SUPERDUTY (Not cab and chassis)**



Read pages 2-3 of these instructions before starting installation. Failure to do so could result in significant vehicle damage!

IMPORTANT NOTES FOR THIS INSTALLATION:

1. On short bed vehicles, attach Driver's Side forward bracket on Row 2 to avoid interference with fuel lines.
2. On vehicles with overload springs, switch position of long and short brackets.
3. You may need to move the mounting rail location +/- 1/2" to ensure frame brackets do not interfere with bed sills.

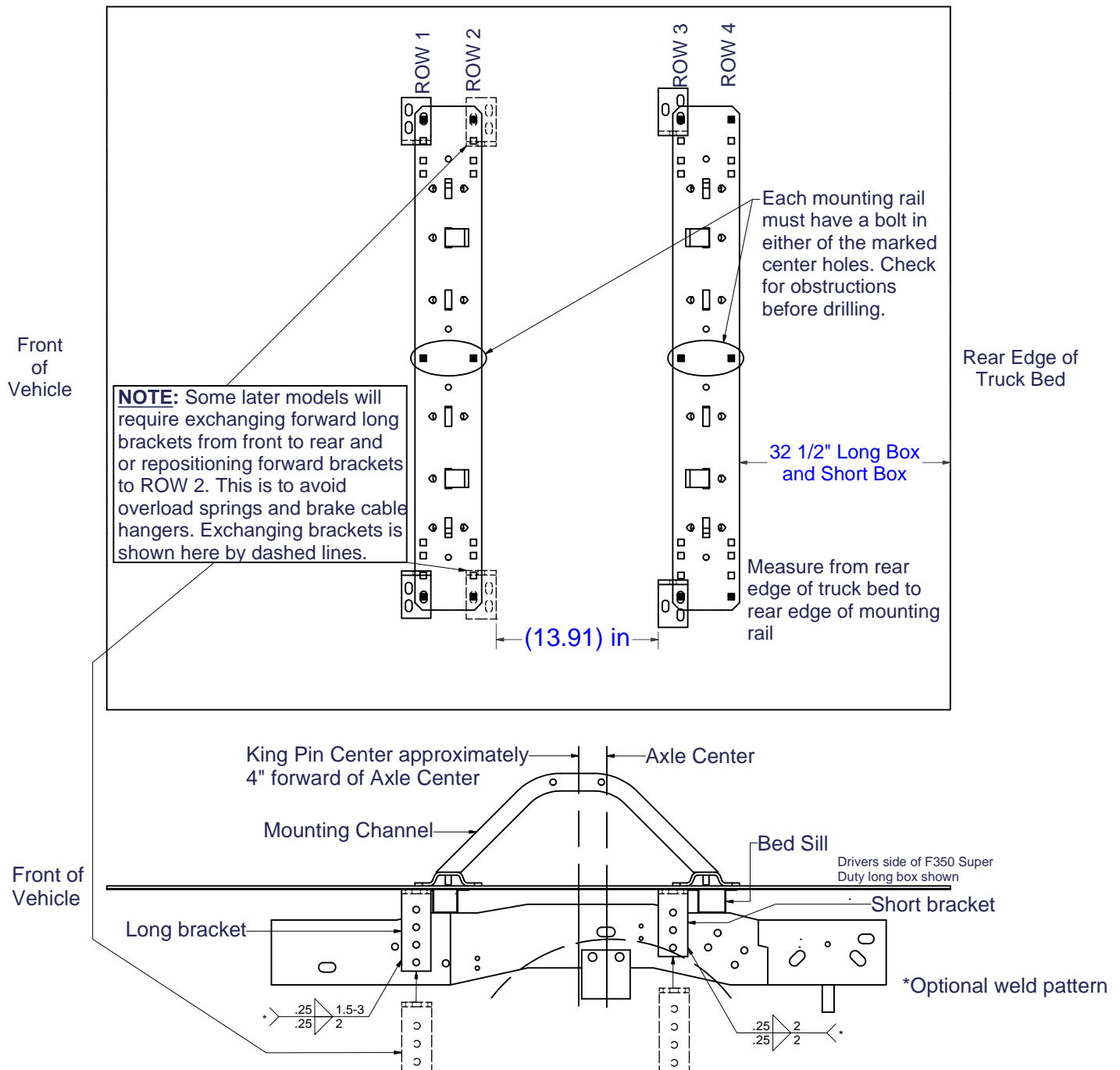

Check for obstructions before drilling. Failure to do so could result in damaged fuel or brake lines, structural members, etc. CURT MANUFACTURING does its best to communicate tow vehicle manufacturer changes; however, it is ultimately the responsibility of the installer to prevent damage due to installation.

DODGE '02 TO '08 1500, '03 AND NEWER 2500 WITHOUT OVERLOAD BRACKETS



Read pages 2-3 of these instructions before starting installation. Failure to do so could result in significant vehicle damage!

IMPORTANT NOTES FOR THIS INSTALLATION:

1. Tube spacer and 4 1/2" carriage bolt used to attach through rearward Bed Sill (Row 3).
2. **Rib neck bolts will need to be pulled through access holes in frame with supplied pull wire (see below).
3. Do not drill thru both walls of frame. Drill only thru wall of frame to which bracket is mounted.
4. It is very important that brackets in Row 2 are against rear side of Bed Sill as shown. Due to dimensional instability in Bed Sill placement with the Dodge truck, interference could result when drilling in Row 3. Observe caution note below and double check all areas prior to drilling.
5. To avoid drilling inside of frame, (Passenger Side Row 3) Optional Custom Bracket (16303) can be purchased from your dealer. The use of this bracket allows for drilling outside the frame and avoids exhaust hanger.
6. *Due to tubular frames having thinner walls than previous C channel frames, extra caution needs to be used when mounting with the optional welding.

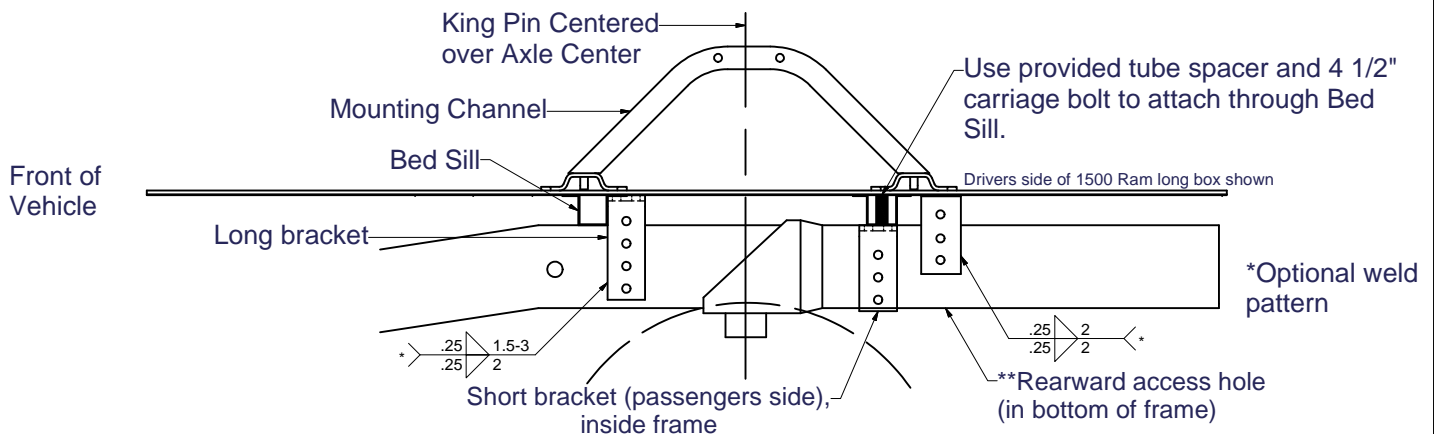
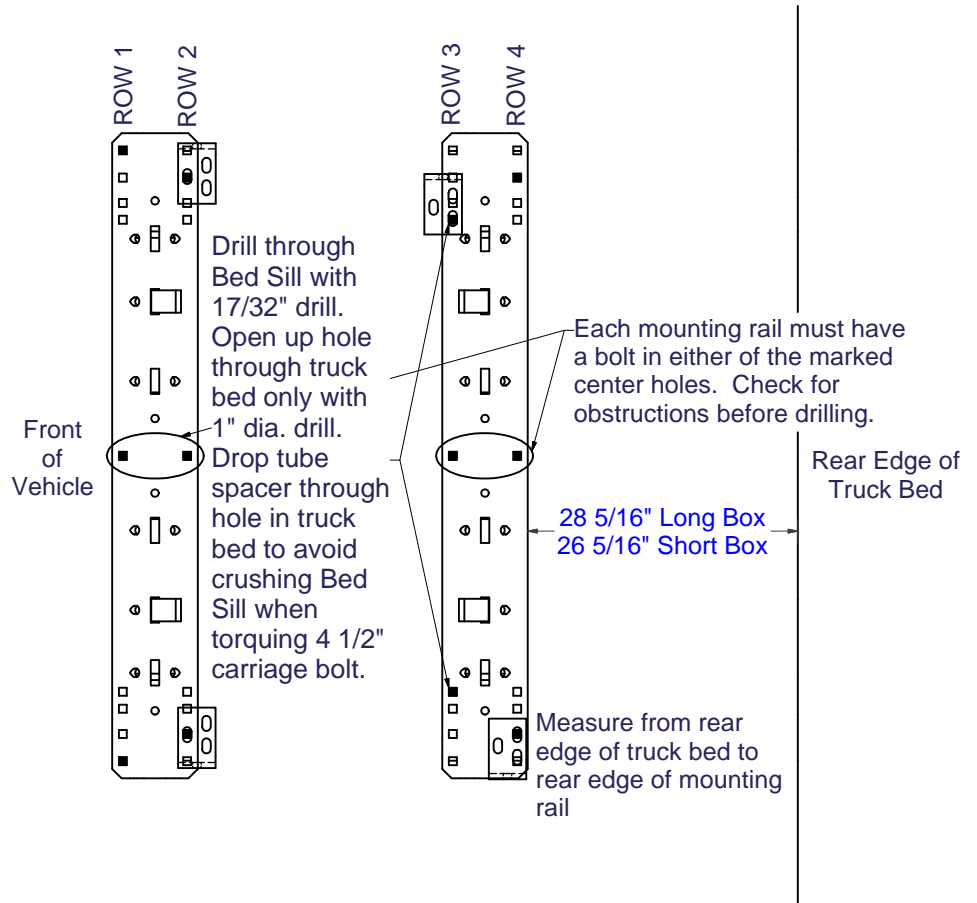

Check for obstructions before drilling. Failure to do so could result in damaged fuel or brake lines, structural members, etc. CURT MANUFACTURING does its best to communicate tow vehicle manufacturer changes; however, it is ultimately the responsibility of the installer to prevent damage due to installation.

**DODGE '03 AND NEWER 2500 WITH OVERLOAD SPRINGS
3500 (REQUIRES 16301 BRACKET KIT)**



Read pages 2-3 of these instructions before starting installation. Failure to do so could result in significant vehicle damage!

IMPORTANT NOTES FOR THIS INSTALLATION:

1. Tube spacer and 4 1/2" carriage bolt used to attach through rearward Bed Sill (Row 3).
2. **Rib neck bolts will need to be pulled through access holes in frame with supplied pull wire (see below).
3. Do not drill thru both wall of frame. Drill only thru wall of frame to which bracket is mounted.
4. It is very important that brackets in Row 2 are against rear side of Bed Sill as shown. Due to dimensional instability in Bed Sill placement with the Dodge truck, interference could result when drilling in Row 3. Observe caution note below and double check all areas prior to drilling.
5. Rear brackets can be mounted to frame with (2) bolts in any combination of the three bracket holes.
6. *Due to tubular frames having thinner walls than previous C channel frames, extra caution needs to be used when mounting with the optional welding.

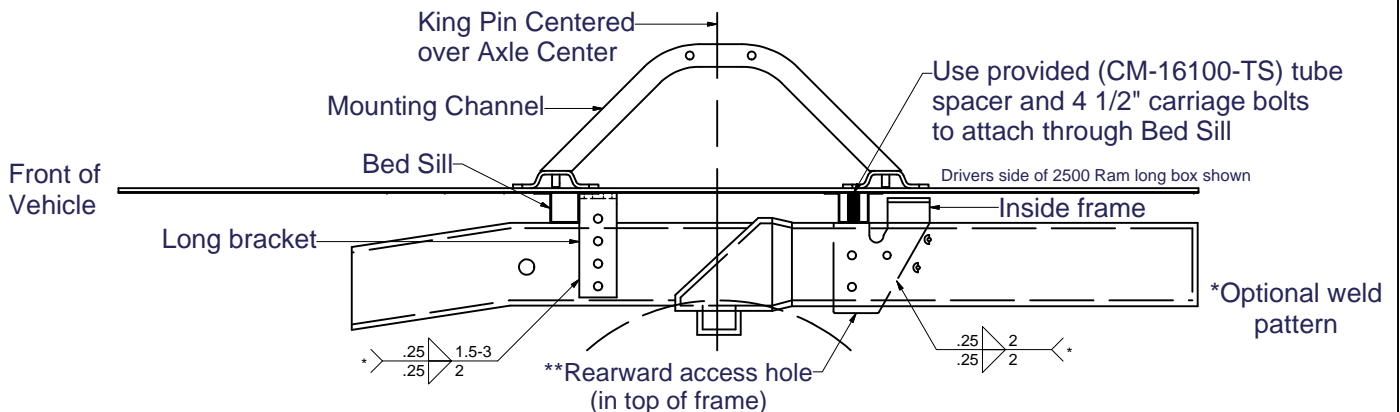
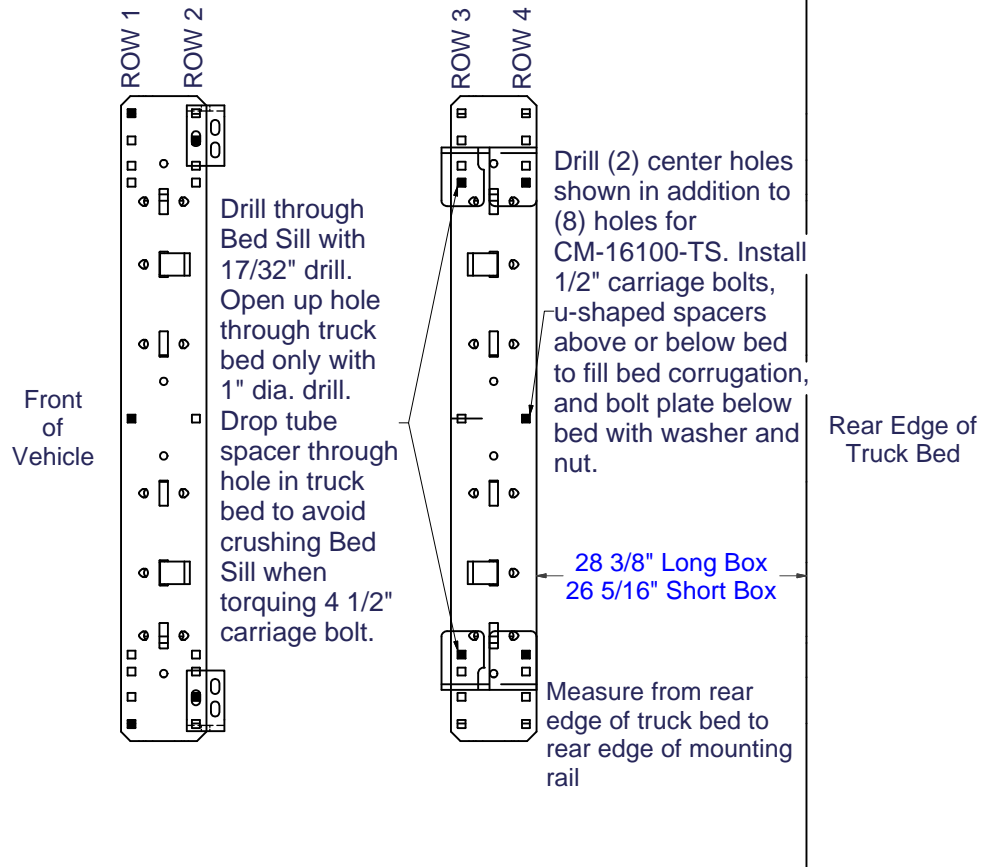

Check for obstructions before drilling. Failure to do so could result in damaged fuel or brake lines, structural members, etc. CURT MANUFACTURING does its best to communicate tow vehicle manufacturer changes; however, it is ultimately the responsibility of the installer to prevent damage due to installation.

**DODGE '02 THRU '08 1500 (16303 CUSTOM BRACKET KIT)
2500 WITHOUT OVERLOAD SPRINGS**



Read pages 2-3 of these instructions before starting installation. Failure to do so could result in significant vehicle damage!

IMPORTANT NOTES FOR THIS INSTALLATION:

1. Tube spacer and 4 1/2" carriage bolt used to attach through rearward Bed Sill (Row 3).
2. **Rib neck bolts will need to be pulled through access holes in frame with supplied pull wire (see below).
3. Do not drill thru both walls of frame. Drill only thru wall of frame to which bracket is mounted.
4. It is very important that brackets in Row 2 are against rear side of Bed Sill as shown. Due to dimensional instability in Bed Sill placement with the Dodge truck, interference could result when drilling in Row 3. Observe caution note below and double check all areas prior to drilling.
5. *Due to tubular frames having thinner walls than previous C channel frames, extra caution needs to be used when mounting with the optional welding.

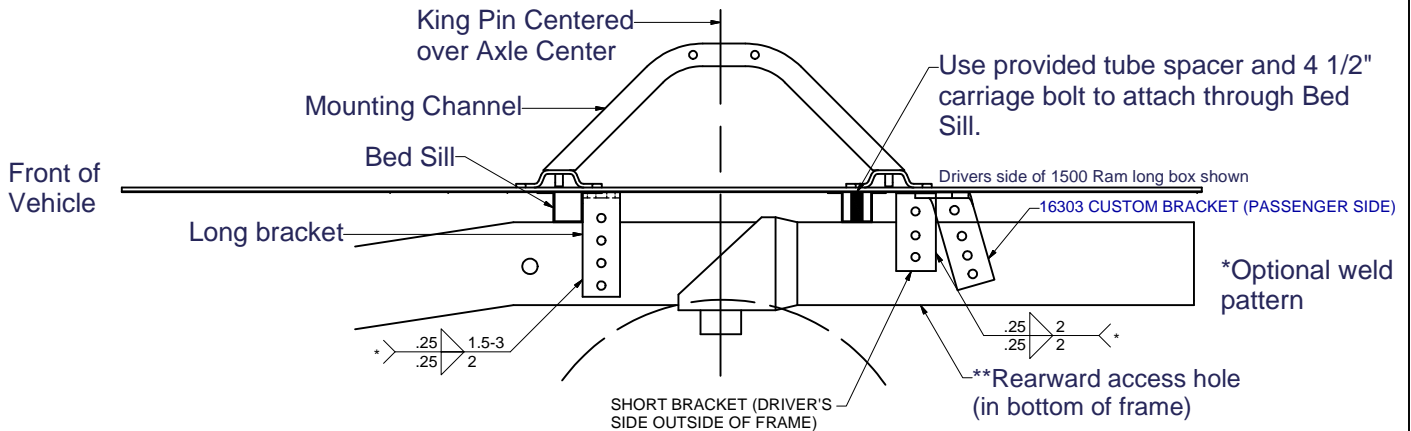
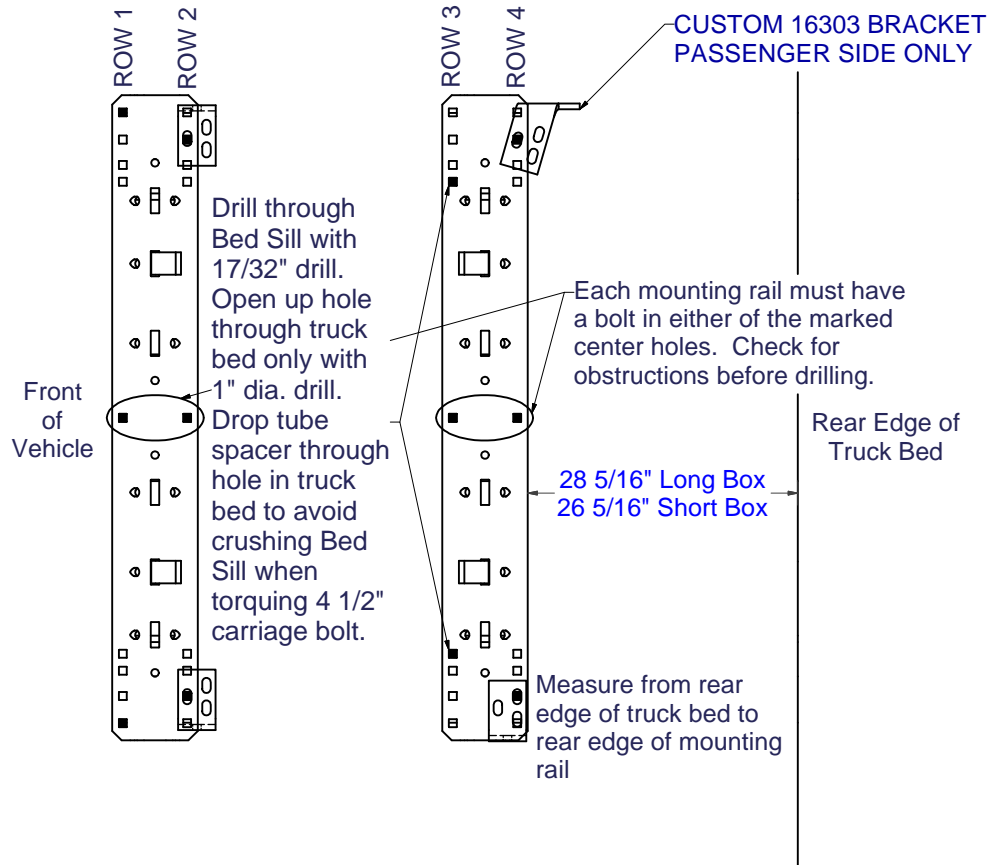

Check for obstructions before drilling. Failure to do so could result in damaged fuel or brake lines, structural members, etc. CURT MANUFACTURING does its best to communicate tow vehicle manufacturer changes; however, it is ultimately the responsibility of the installer to prevent damage due to installation.

DODGE '09 TO '11 1500 (16305 CUSTOM BRACKET KIT)



Read pages 2-3 of these instructions before starting installation. Failure to do so could result in significant vehicle damage!

IMPORTANT NOTES FOR THIS INSTALLATION:

1. *Rib neck bolts will need to be pulled through access holes in frame with supplied pull wire (see below).
2. Observe caution note below and double check all areas prior to drilling.
3. **Do not drill thru both walls of frame. Drill only thru wall of frame to which bracket is mounted.
4. ***It may be necessary to notch ends of bed sill in Row 3 to allow access to and the bolting down of mounting rail hardware.
5. ****Due to tubular frames

having thinner walls than previous C channel frames, extra caution needs to be used when mounting with the optional welding.

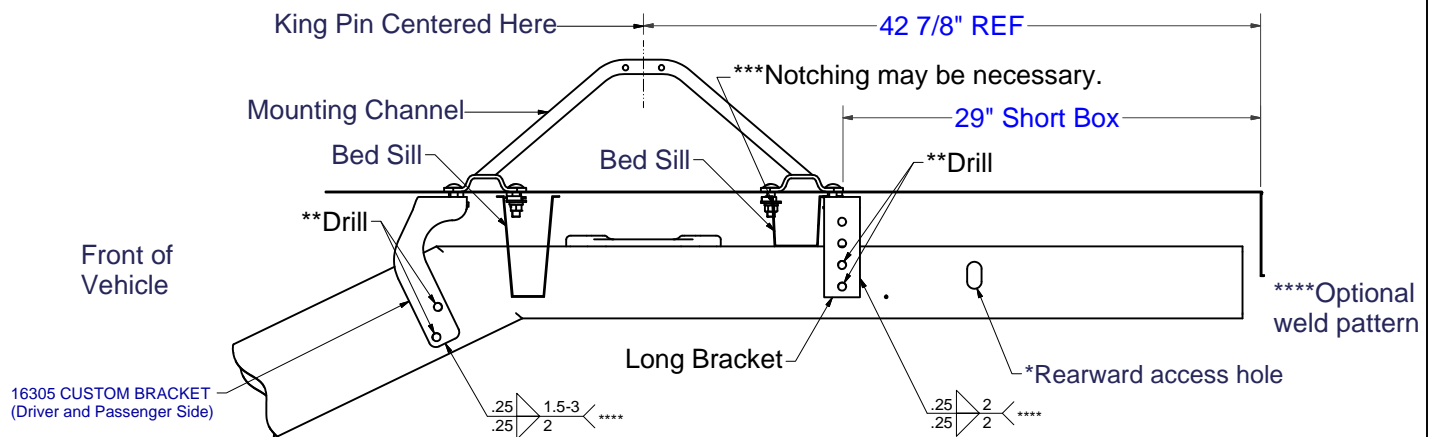
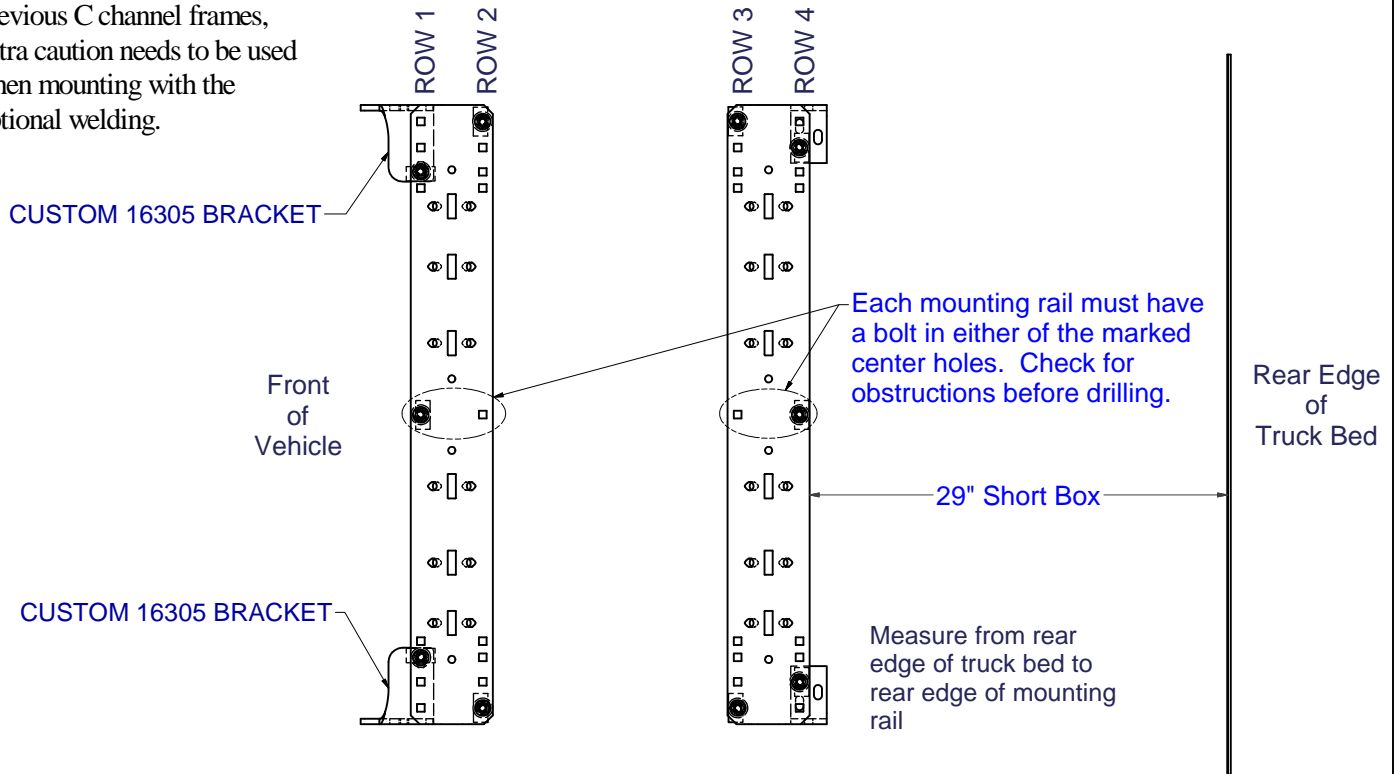

Check for obstructions before drilling. Failure to do so could result in damaged fuel or brake lines, structural members, etc.
 CURT MANUFACTURING does its best to communicate tow vehicle manufacturer changes; however, it is ultimately the responsibility of the installer to prevent damage due to installation.

DODGE '94 TO '01 1500, '94 TO '02 2500/3500 (FULL SIZE, SHORT AND LONG BOX)



Read pages 2-3 of these instructions before starting installation. Failure to do so could result in significant vehicle damage!

IMPORTANT NOTES FOR THIS INSTALLATION:

1. It is very important that brackets in Row 2 are against forward side of bed sill as shown below. Due to dimensional instability in bed sill placement with the Dodge truck, interference could result when drilling in Rows 3 or 4. You may need to move the mounting rail location +/- 1/2" to ensure frame brackets do not interfere with bed sills.

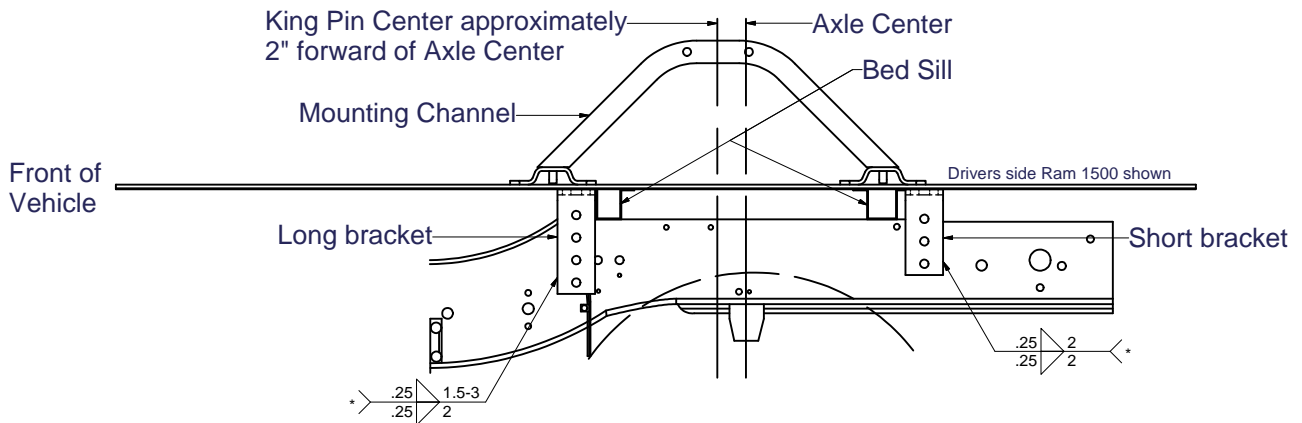
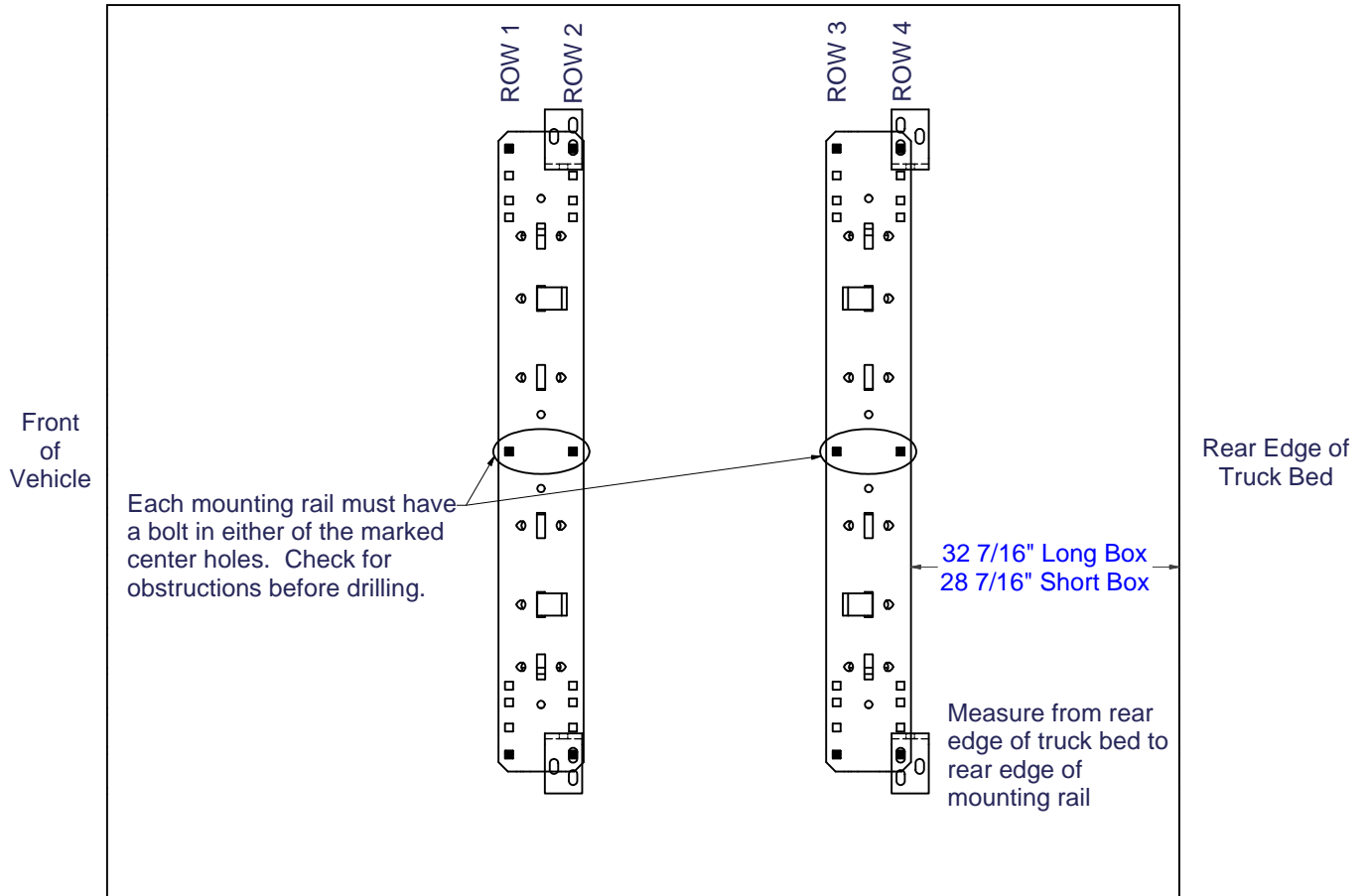

Check for obstructions before drilling. Failure to do so could result in damaged fuel or brake lines, structural members, etc. CURT MANUFACTURING does its best to communicate tow vehicle manufacturer changes; however, it is ultimately the responsibility of the installer to prevent damage due to installation.

DODGE THROUGH 93 (FULL SIZE)



Read pages 2-3 of these instructions before starting installation. Failure to do so could result in significant vehicle damage!

IMPORTANT NOTES FOR THIS INSTALLATION:

1. You may need to move mounting rail location +/- 1/2" to ensure frame brackets do not interfere with bed sills.

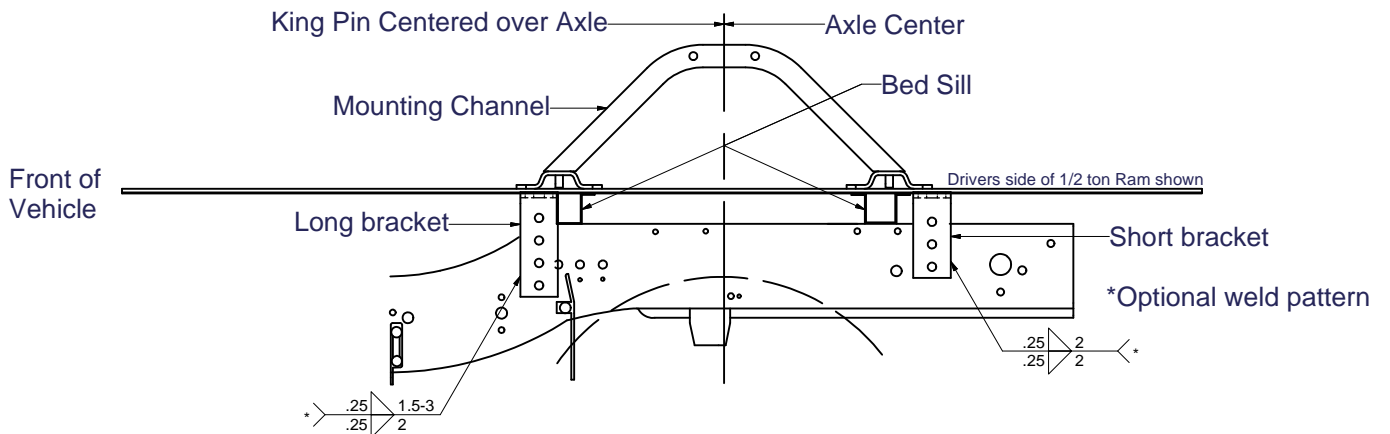
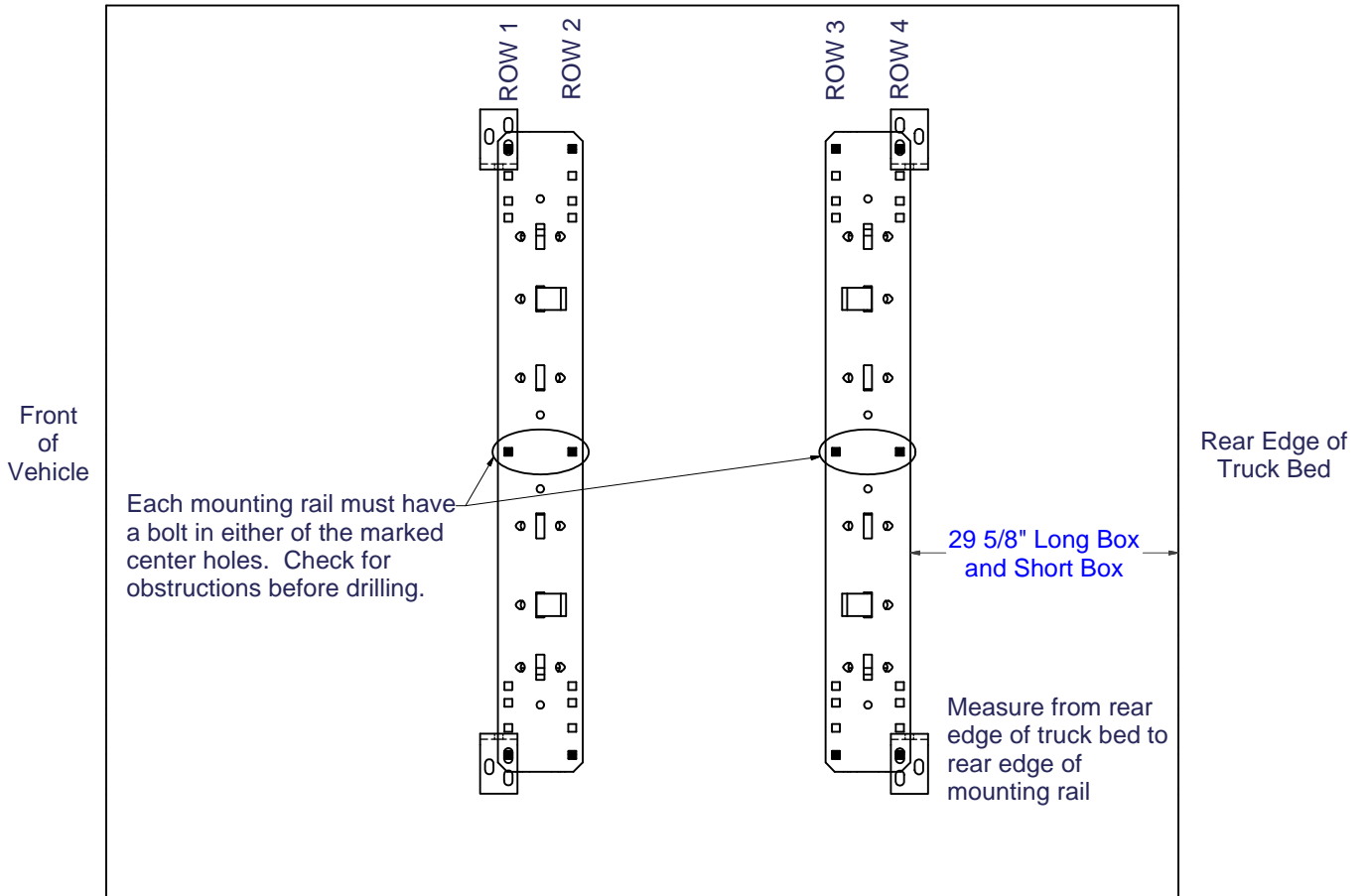

Check for obstructions before drilling. Failure to do so could result in damaged fuel or brake lines, structural members, etc. CURT MANUFACTURING does its best to communicate tow vehicle manufacturer changes; however, it is ultimately the responsibility of the installer to prevent damage due to installation.

DODGE '94 TO 2004 DAKOTA



Read pages 2-3 of these instructions before starting installation. Failure to do so could result in significant vehicle damage!

IMPORTANT NOTES FOR THIS INSTALLATION:

1. Find parallel rows of bed sill spot welds in bed of truck. No drilling should be done in the ~4" between parallel rows of spot welds where the bed sill sits.
2. Cut 1" from top flange of brackets. Under bed, mount brackets with flanges facing out.
3. Put rear brackets on Row 3 for '97 to Present models. Put brackets on Row 4 for '96 and Earlier models.

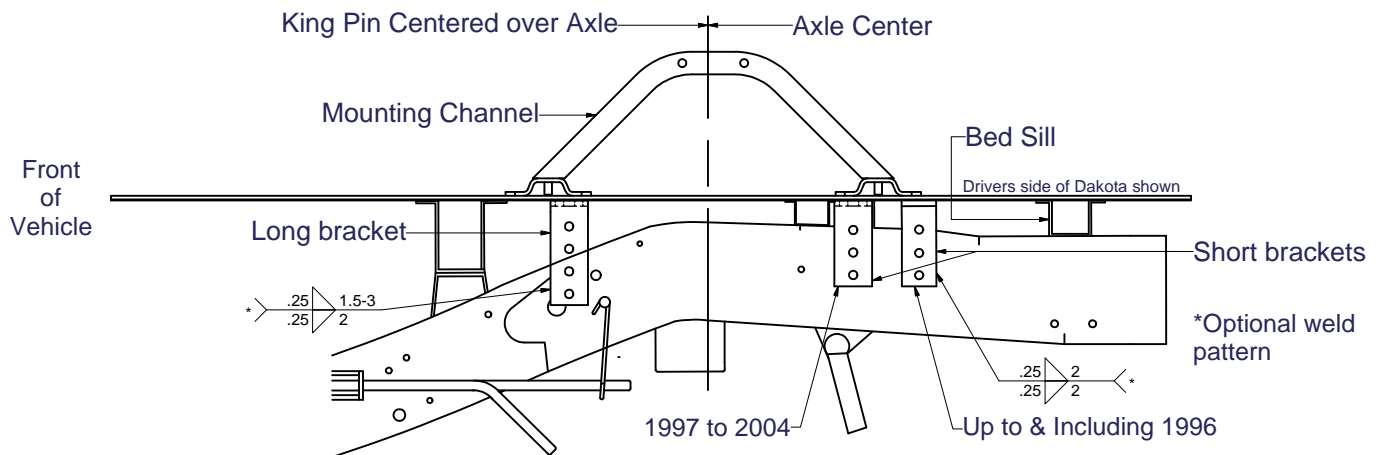
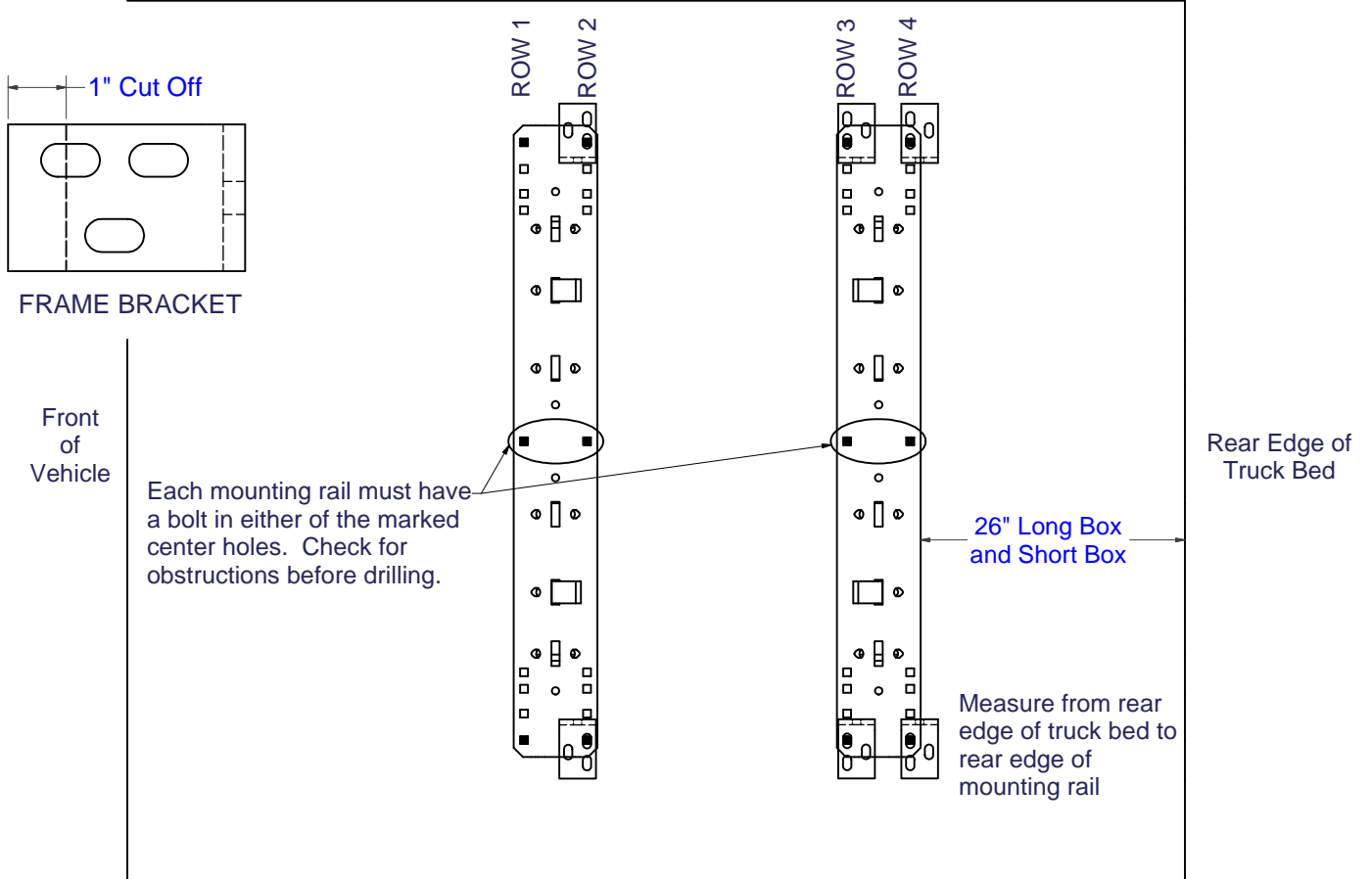

Check for obstructions before drilling. Failure to do so could result in damaged fuel or brake lines, structural members, etc. **CURT MANUFACTURING** does its best to communicate tow vehicle manufacturer changes; however, it is ultimately the responsibility of the installer to prevent damage due to installation.

TOYOTA TUNDRA 2000 TO 2006 (STANDARD CAB LONG BOX ONLY)



Read pages 2-3 of these instructions before starting installation. Failure to do so could result in significant vehicle damage!

NOTE: For Toyota Tundra application, part #16302 spacer kit is required. Stack (1) 3/16" and (1) 5/16" thick slotted spacers as required to avoid crushing of truck bed.

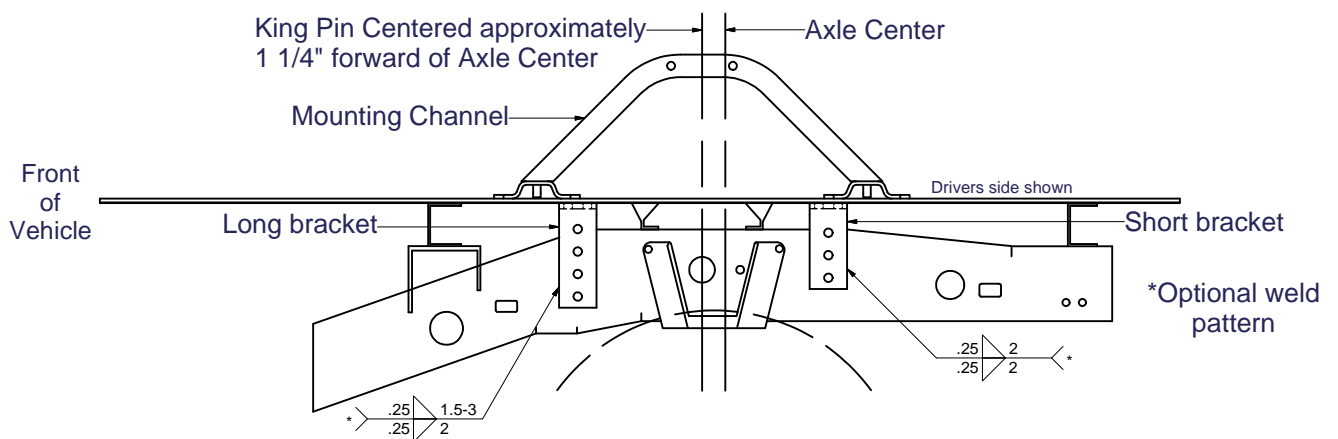
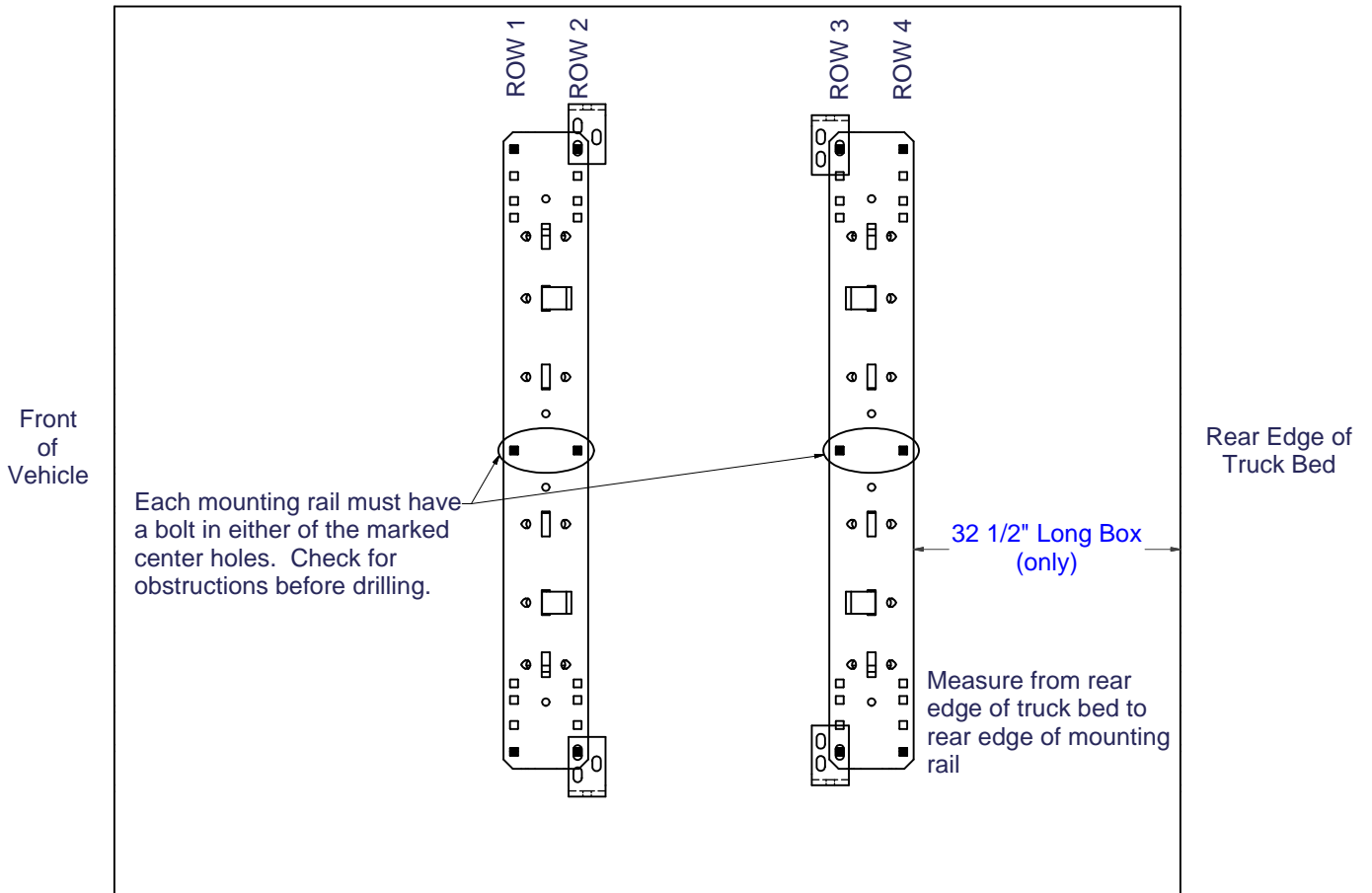

Check for obstructions before drilling. Failure to do so could result in damaged fuel or brake lines, structural members, etc. CURT MANUFACTURING does its best to communicate tow vehicle manufacturer changes; however, it is ultimately the responsibility of the installer to prevent damage due to installation.

TOYOTA 2007 AND NEWER TUNDRA, 6.5' & 8' BEDS, DOES NOT FIT CREWMAX



Read pages 2-3 of 16100 instructions before starting installation. Failure to do so could result in significant vehicle damage!

IMPORTANT NOTES FOR THIS INSTALLATION:

- 1) Use the 16304 add-on kit with the 16100 universal kit. Read pages 1-3 of the 16100 instruction for general information.
- 2) The mounting holes for row 3 go through the inside of the bed sill. Make sure it lines up correctly. Drill through the bed and the top of the frame on both sides. For the Row 4 passenger side attachment, drill through the bed and top of the frame as well.
- 3) The rear rail on the passenger side is secured directly to the frame with 3" carriage bolts provided in the 16304 kit. For the row 3 attachment, a tube spacer should be placed inside the bed sill on top of the frame and under the bottom of the bed. Line up the spacer with the drilled hole before inserting the carriage bolt. Repeat for both sides. See FIG. 1 below.

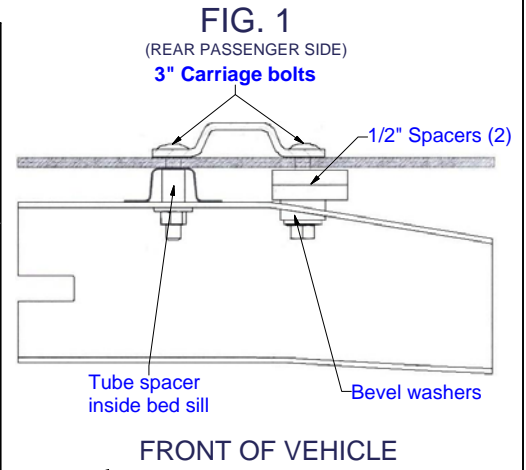
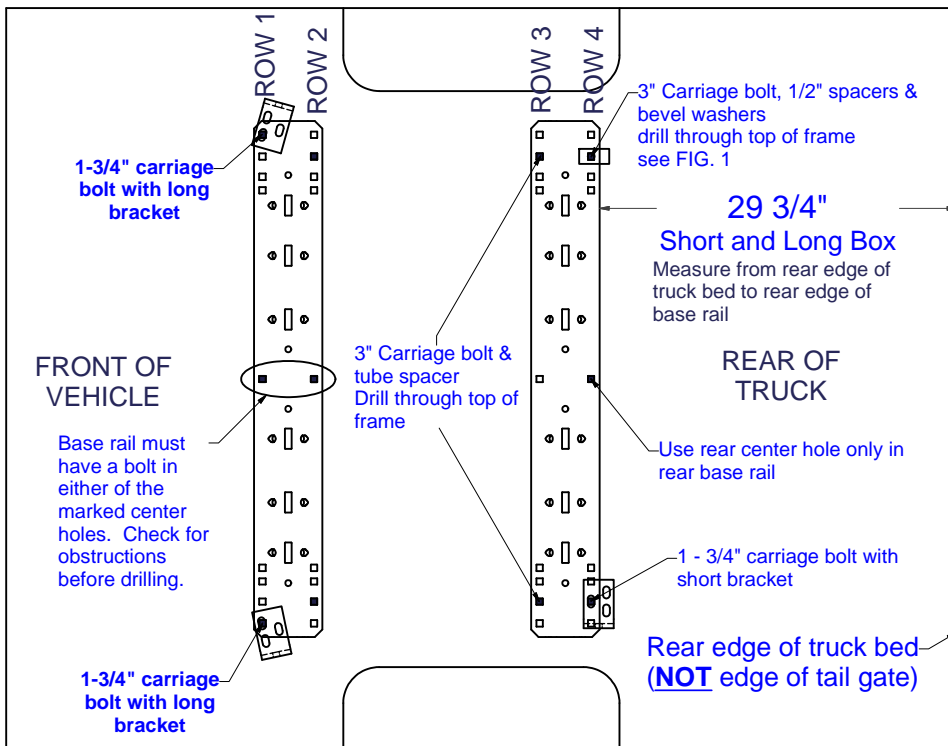

- 4) For the Row 4 passenger side attachment, stack two 1/2" spacers and a bevel washer, provided in the 16304 kit, to fill the gap between the bed and the frame. Use another bevel washer, conical toothed washer, and hex nut to fasten the 3" carriage bolt in place. See FIG. 1.

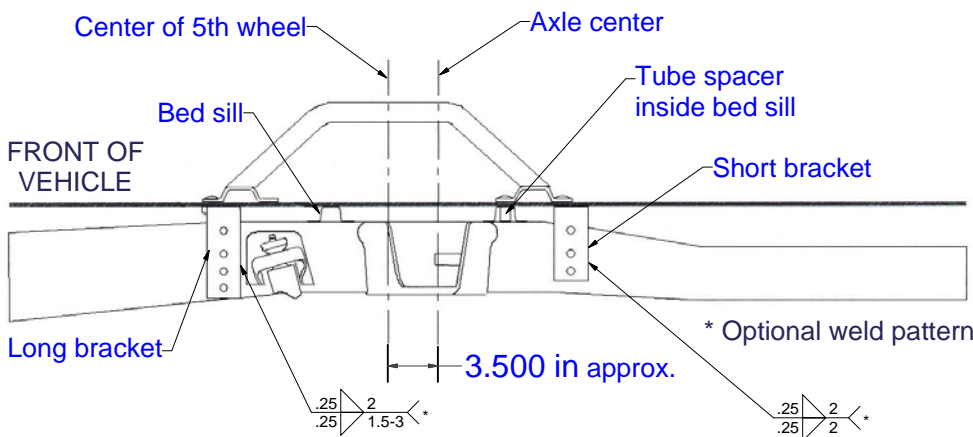

- 5) Install the long brackets on the front rail and the short bracket on the rear driver side rail using the 1 - 3/4" carriage bolts provided in the 16304 kit. All other attachments to the bed use 2" carriage bolts from the 16100 kit.



Check for obstructions before drilling. Failure to do so could result in damaged fuel or brake lines, structural members, etc. CURT MANUFACTURING does its best to communicate tow vehicle manufacturer changes; however, it is ultimately the responsibility of the installer to prevent damage due to installation.

NOTES

FIVE YEAR LIMITED WARRANTY

CURT MANUFACTURING warrants its 5th Wheel Hitch Mounting Kits from date of purchase against defects in material and workmanship under normal use and service, for 5 years of ownership to the original purchaser when a CURT MANUFACTURING mounting kit is used.

CURT MANUFACTURING will replace FREE OF CHARGE any part, which proves defective in material or workmanship when presented to any CURT MANUFACTURING dealer, CURT MANUFACTURING Warehouse or returned to the factory. TRANSPORTATION CHARGES PREPAID, at the address below. THIS WARRANTY IS LIMITED TO DEFECTIVE PARTS REPLACEMENT ONLY. LABOR CHARGES AND/OR DAMAGE INCURRED IN INSTALLATION OR REPLACEMENT AS WELL AS INCIDENTAL AND CONSEQUENTIAL DAMAGES CONNECTED THEREWITH ARE EXCLUDED.

Some states do not allow the exclusion or limitation of incidental or consequential damages, so the above limitation or exclusion may not apply to you.

Any damage to the 5th Wheel Hitch as a result of misuse, abuse, neglect, accident, improper installation, or any use that violates the instructions furnished by us, WILL VOID THE WARRANTY.

Curt Manufacturing, Inc.
6208 Industrial Drive
Eau Claire, WI 54701