

## Stamped Steel Override for Arcus Front Bumper

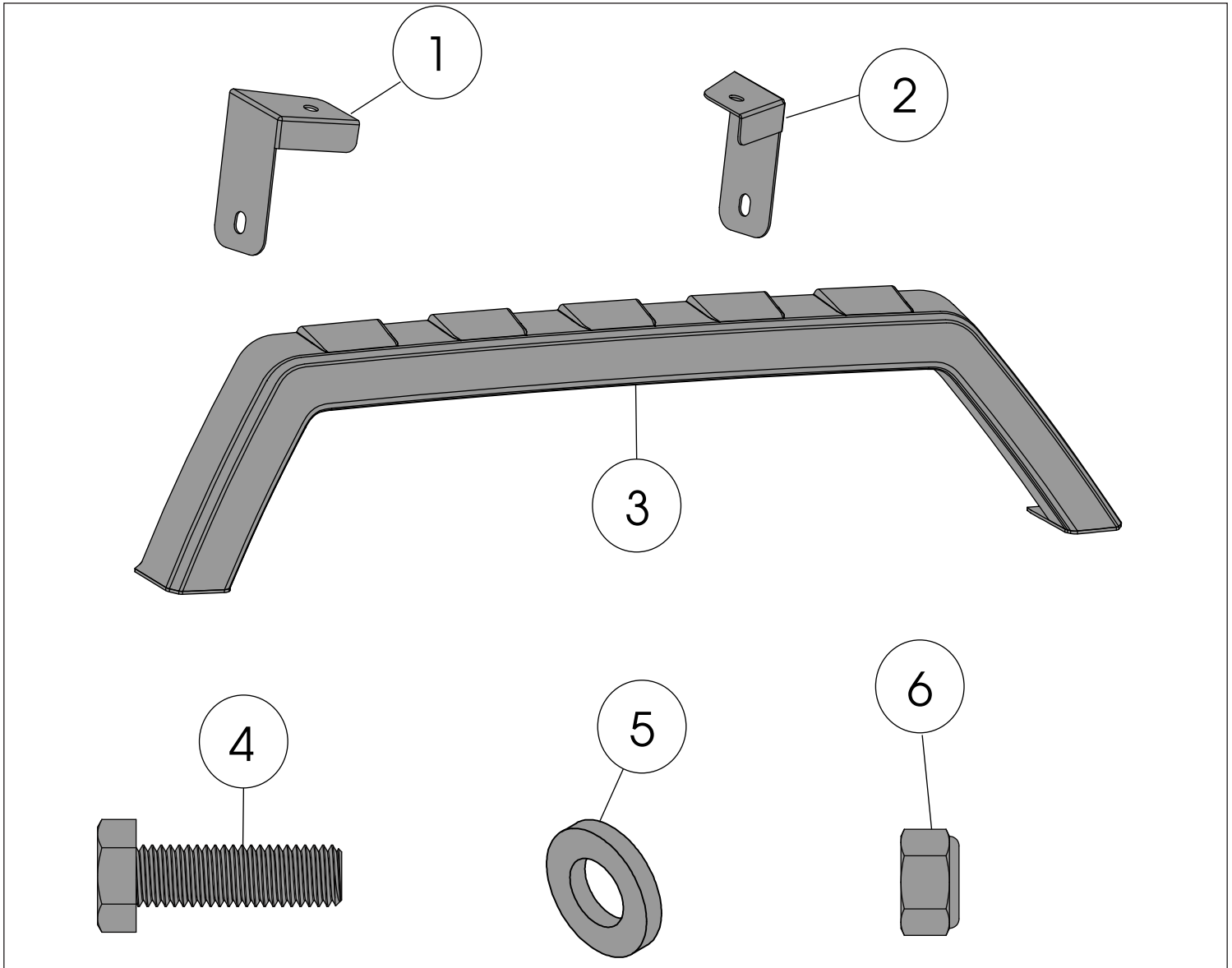

### Components

1. Right Override Mounting Bracket	(1)	4. M10 Bolt	(2)
2. Left Override Mounting Bracket	(1)	5. M10 Washer	(4)
3. Stamped Override	(1)	6. M10 Nut	(2)

#### OMIX-ADA® TECHNICAL SUPPORT

PHONE: M-F 8am - 5pm EST 1-800-449-6649

FOR WARRANTY OR TECH CONCERNS EMAIL: [webmaster@omixsupport.com](mailto:webmaster@omixsupport.com)

#### ATTN: STATE OF CALIFORNIA CONSUMERS

**⚠ WARNING: Cancer and Reproductive Harm - [www.P65Warnings.ca.gov](http://www.P65Warnings.ca.gov).**



460 HORIZON DR. | SUWANEE, GA 30024 | PHONE: 770-614-6101 | FAX: 844-270-0593 | www.Omix-ADA.com

## Stamped Steel Override for Arcus Front Bumper

**NOTICE** Perform steps 1-5 on the Front Bumper's Instruction Sheet.

1. Reusing OE bolts, loosely attach override mounting brackets to frame.

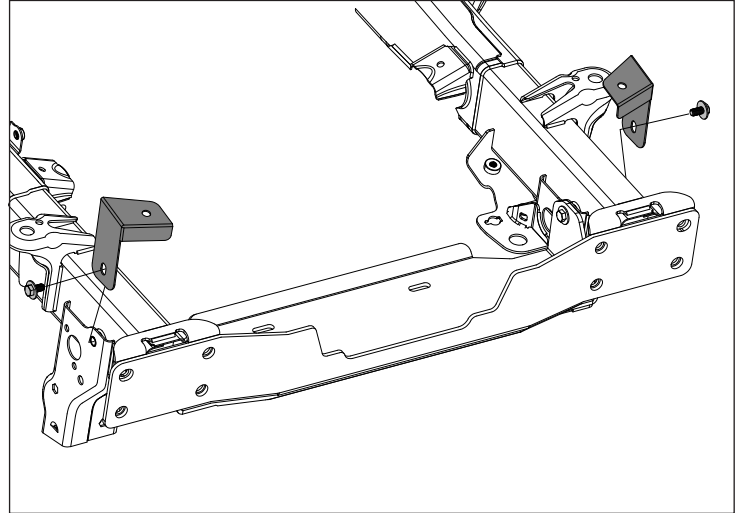

**NOTICE** Complete steps 7-8 on the Front Bumper Instruction Sheet.

2. Align stamped override to override mounting brackets and bumper shell. Using supplied M10 bolt, nut, and washer, loosely attach stamped override.

