

# License Plate Relocation, JL

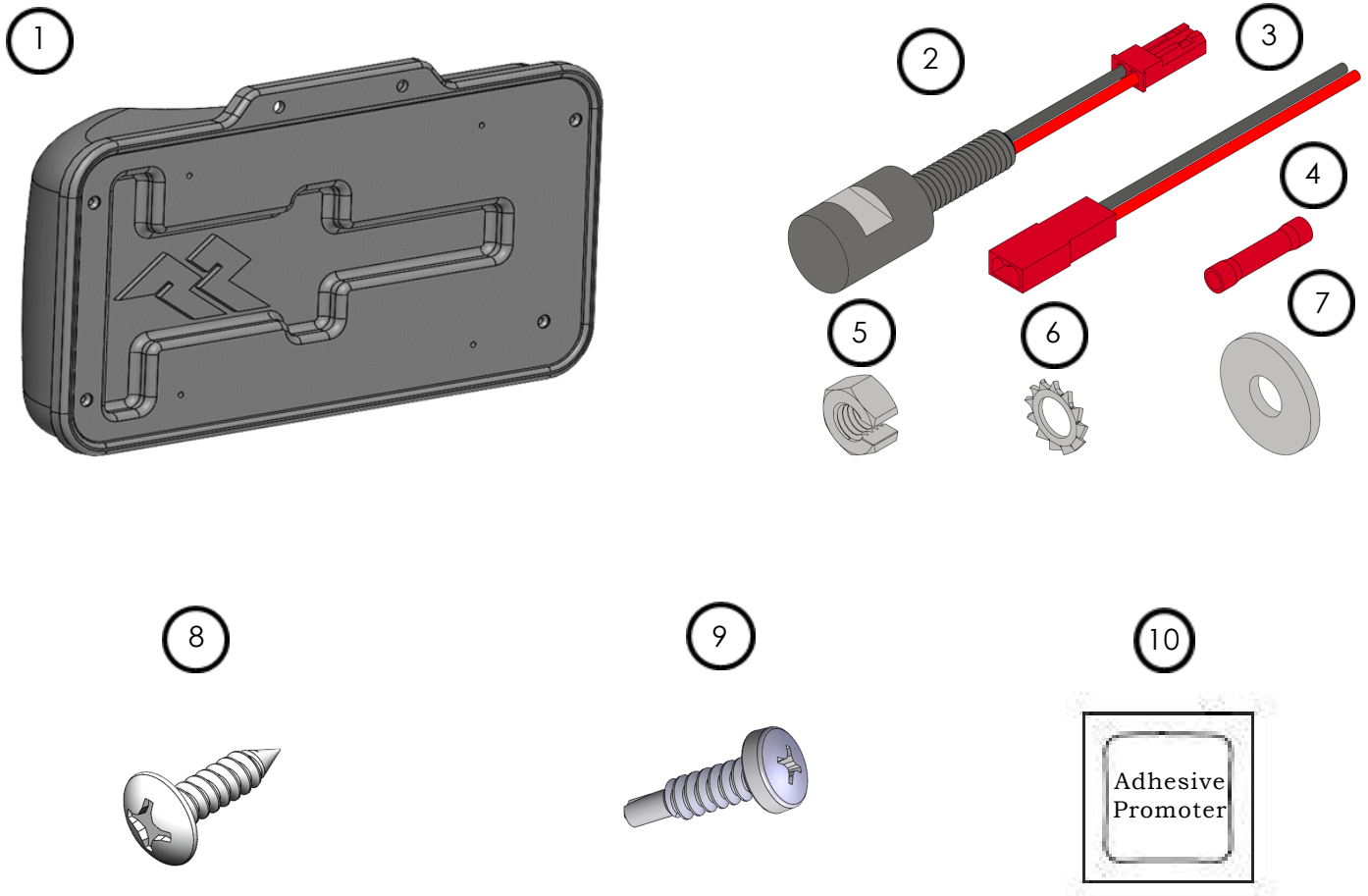

## Components

1. Plastic License Plate.....(1)	8. # 14 x 3/4" Pan Head Sheet Metal Screw.....(4)
2. LED License Plate Bolt.....(2)	9. # 10 x 3/4" Self-Tapping Sheet Metal Screw.....(2)
3. Female Connector.....(2)	10. Adhesive Promoter.....(1)
4. Butt Connector.....(2)	
5. M6 Slit Nut.....(2)	
6. M6 Lock Washer.....(2)	
7. M6 Flat Washer.....(2)	

**OMIX-ADA® TECHNICAL SUPPORT**

PHONE: M-F 8am - 5pm EST 1-800-449-6649 | EMAIL: techsupport@omix-ada.com

FOR WARRANTY INFORMATION VISIT: [www.Omix-Ada.com](http://www.Omix-Ada.com)

## License Plate Relocation, JL

1. Cut and strip OE license plate light wiring 2 inches from plug.

Using supplied butt connector splice red wires from both supplied Male Connectors into positive wire from license plate wiring.

Using supplied butt connector splice black wires from both supplied Male Connectors into negative wire from license plate wiring.

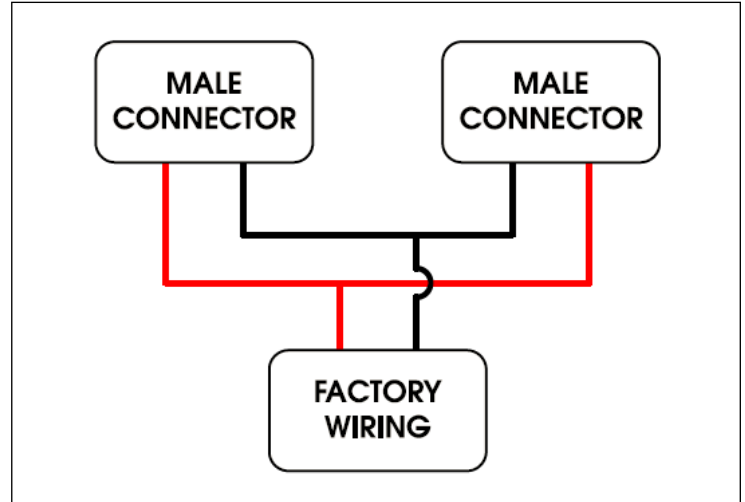

2. Slide supplied M6 Flat Washer and M6 Lock Washer over male plug on LED License Plate Bolt and install M6 Slit Nut over wires.

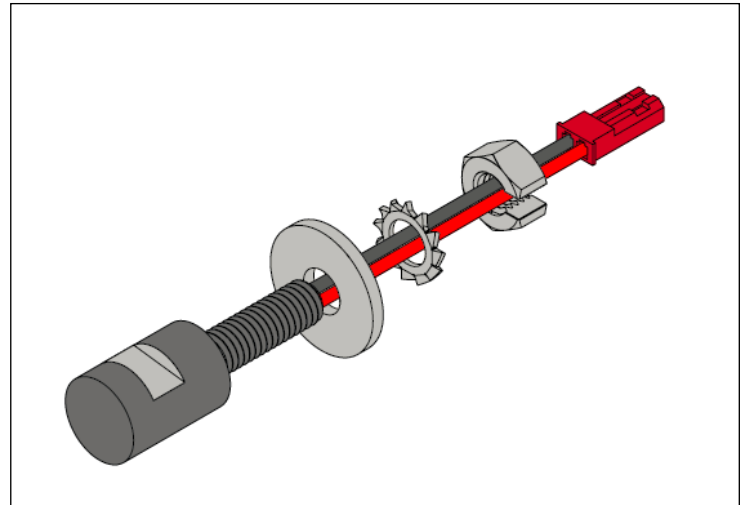

3. Connect LED License Plate Bolts to the spliced Female Connectors. Turn on lights and aim correctly at license plate.

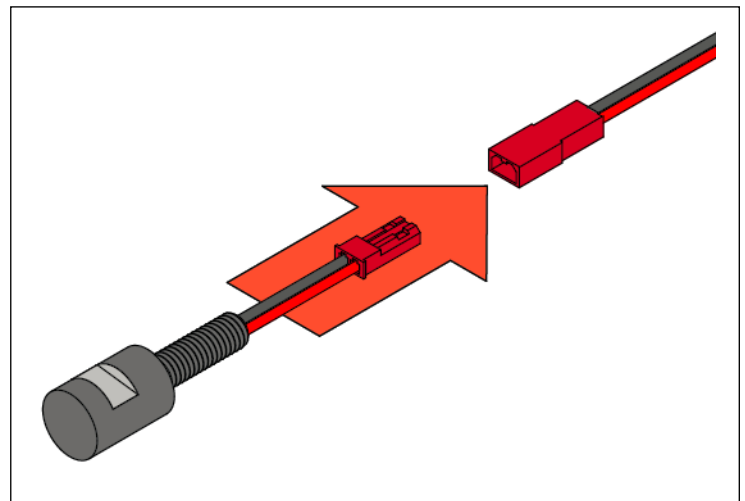



460 HORIZON DR. SUITE 400 | SUWANEE, GA 30024 | PHONE: 770-614-6101 | FAX: 770-614-6069 | info@omix-ada.com

## License Plate Relocation, JL

4. Install the LED Bolts in the top of the license plate holder.

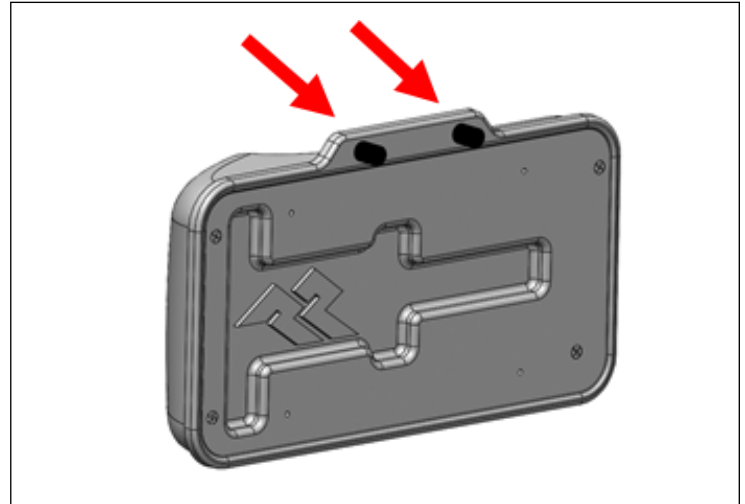

5. Test fit item to the vehicle before mounting . This will aid in aligning the item before adhesion.

You can use painter's tape or masking tape for positioning the product.

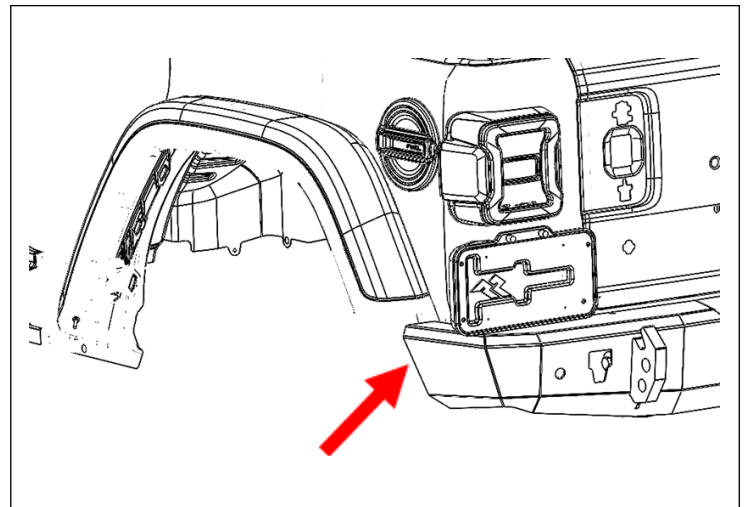

6. Clean surface with alcohol and apply adhesive promoter to mounting surface. Allow 90 seconds for adhesive promoter to dry before proceeding.

**Notice:** For proper installation, mounting surface of vehicle should be between 40-100°F (4-38°C) prior to application.

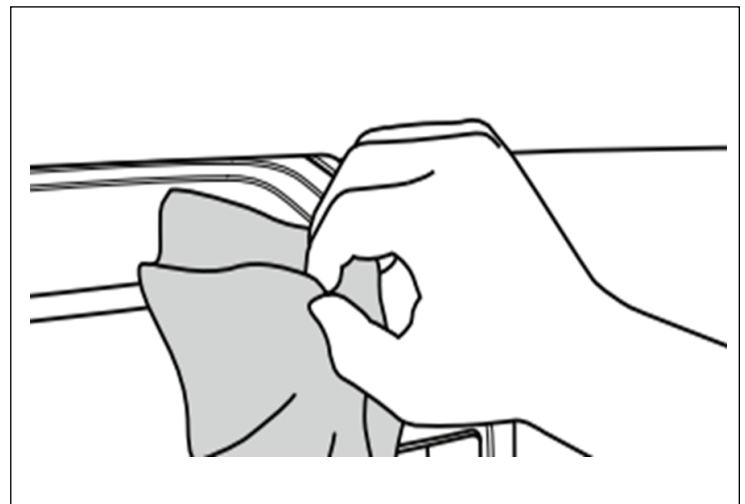



OMIX-ADA, Inc.

Part #11238.16

460 HORIZON DR. SUITE 400 | SUWANEE, GA 30024 | PHONE: 770-614-6101 | FAX: 770-614-6069 | info@omix-ada.com

# License Plate Relocation, JL

7. Apply 3M Tape to the mounting areas as shown in the picture.

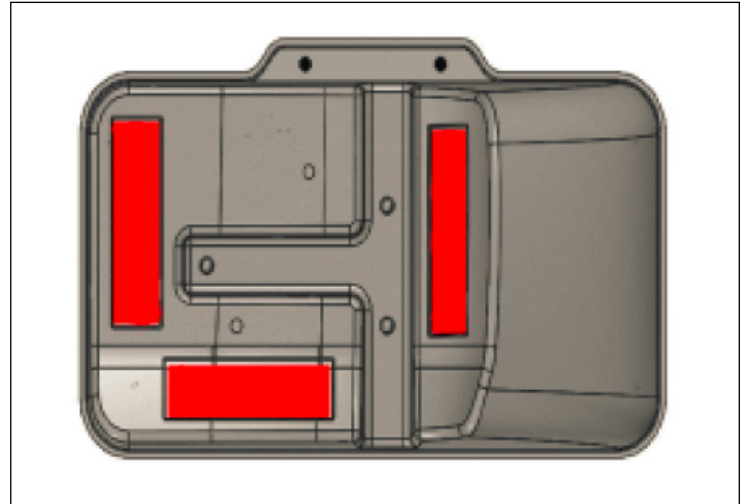

8. Remove the plastic liner from the tape and install item then firmly hold it in proper position.

Maintain pressure on installed item for 30 seconds to ensure proper contact.

Full adhesion occurs within 24 hours of application.

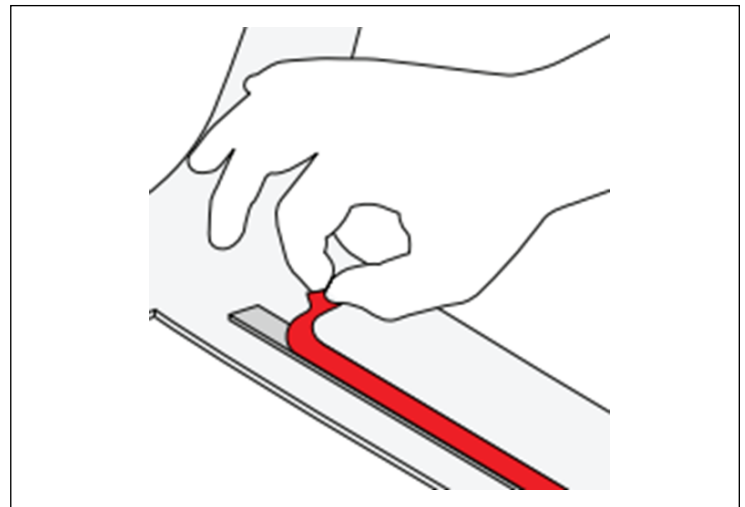

9. **Optional Drilling Instructions:** Unscrew the 4 flat head Phillip screws and remove license plate face. Mark 2 holes then drill pilot holes. Fasten 2 Self-tapping screws as shown in the picture.

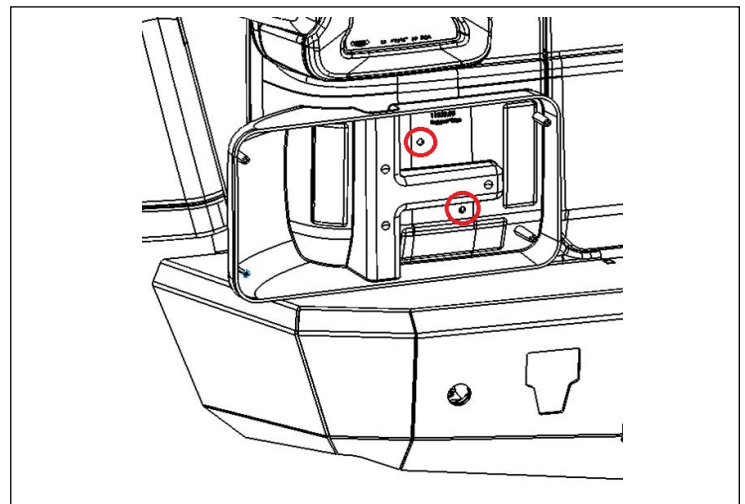



OMIX-ADA, Inc.

Part #11238.16

460 HORIZON DR. SUITE 400 | SUWANEE, GA 30024 | PHONE: 770-614-6101 | FAX: 770-614-6069 | info@omix-ada.com

## License Plate Relocation, JL

10. Re-attach license plate face with flat head Phillips screws.

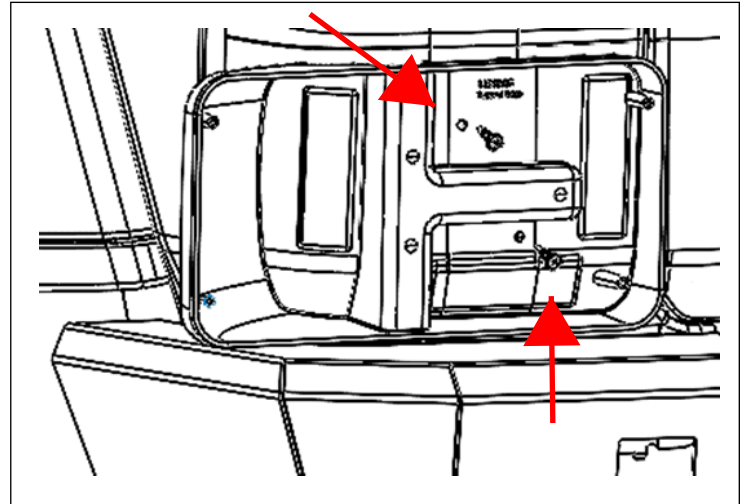

11. Use No.14 Pan Head screws to mount the license plate as shown in the picture.

